

ENTERPRISE SERIES

OIL-FREE ROTARY COMPRESSORS

Tough Liquid Transport Partner

Our Enterprise compressors are proven workhorses for oil-free high pressure discharge of fluids that can cause problems for cargo pumps. The maximum pressure rating of 36psig (2.5 bar-g) is among the highest available.

Cast for Performance

These compact compressors are constructed of corrosion-resistant, hard coated cast iron to withstand harsh environmental and operating conditions. They address containment concerns, purity standards and evacuation of residual product.

Maintenance Friendly

A patented clamping device allows for easy disassembly and reassembly. The unique blade inspection port on the E106 offers easy inspection without removing the compressor from service. European Patent 0.083.481

The blade can be inspected without disassembling the compressor.

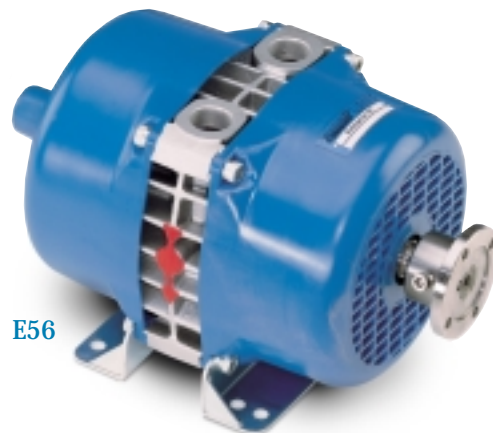

E56



E106



E156

ENTERPRISE SERIES

OIL-FREE, ROTARY COMPRESSORS

| DIMENSIONS | | | | | | |
|------------|--------|-----|---------|-----|----------|-----|
| | E56 | | E106 | | E156 | |
| | IN | MM | IN | MM | IN | MM |
| A | 7 1/2 | 190 | 9 1/2 | 242 | 11 1/8 | 282 |
| B | 7 5/8 | 200 | 9 7/8 | 250 | 11 7/16 | 290 |
| C | 2 | 50 | 3 15/16 | 100 | 5 1/2 | 140 |
| D | 10 1/8 | 257 | 12 1/16 | 307 | 13 11/16 | 348 |

| DISCHARGE | |
|-----------|---|
| E56 | 1" BSP, with 1" BSP to 1.5" NPT adapter |
| E106 | 1.5" NPT flange |
| E156 | 1.5" NPT flange |

| WEIGHT | | | | | |
|--------|------|------|----|------|------|
| E56 | | E106 | | E156 | |
| LB | KG | LB | KG | LB | KG |
| 43 | 19.5 | 77 | 35 | 109 | 49.5 |

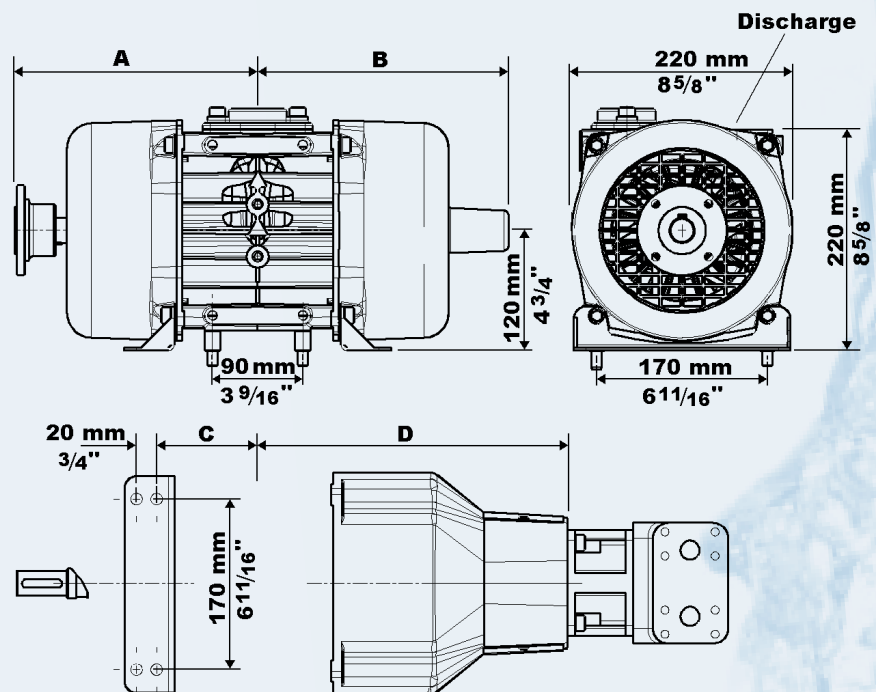

| SPÉCIFICATIONS TECHNIQUES | | | |
|-------------------------------|---------------|--------|--------|
| | E56 | E106 | E156 |
| m ³ /hr (CFM) | 59 | 128 | 173 |
| Air Delivered @ 1600rpm - FAD | (35) | (75) | (102) |
| bar-g (PSIG) | 2,0 | 2,5 | 2,0 |
| Maximum Continuous Pressure | (29) | (36) | (29) |
| Pressure - 1500rpm - (Kw)HP | 4,7 | 8,4 | 10,2 |
| Power Absorbed @ Maximum | (6,3) | (11,3) | (13,7) |
| Recommended Speed Range | 1000-1600 RPM | | |

OPTIONS AND ACCESSORIES

The Enterprise Series compressors are available in PTO or Hydraulic Motor drive versions. Accessories available include:

- Inlet air filter kit
- Discharge pressure check/relief valve
- PTO drive flange
- Hydraulic motor drive adapter
- Hydraulic drive cooler

Sales Information and Equipment Application Assistance

Blackmer has a worldwide distribution network to assist you in specifying any of our family of pumps, compressors and other equipment for your application.

For more information or to find the distributor nearest to you, please contact us at the telephone, fax, or Internet address listed below.

blackmer
PEOPLE PROVIDING FLOW TECHNOLOGY WORLDWIDE A DOVER COMPANY

www.blackmer.com

ZI Plaine des Isles - 2, rue des Caillottes, 89000 Auxerre, France • Téléphone: 33.3.86.49.87.16 • Télécopieur: 33.3.86.49.87.17
 contact@blackmer-mouvex.com
 1809 Century Avenue, Grand Rapids, MI 49503-1530 U.S.A. • Téléphone: 616.241.1611 • Télécopieur: 616.241.3752
 Auf dem Zehnthöbel 22, D - 64572 Büttelborn - Worfelden - Germany • Tel : +49 (0) 6152 9869-0 • Fax : +49 (0) 6152 9869-10
 willkommen@blackmer-mouvex.com

Distributed by: