

SERVICE and OPERATOR'S MANUAL

STRAINER LS/AS 150

CODE: MA/013/21/EN
REV: 00
DATED: 07/2007

ISOIL IMPIANTI S.p.A. – Italy

Sede e Stabilimento
Head office and factory
24061 Albano S. Alessandro (BG)
74, via Madonna delle Rose
Tel. +39 035 4239.011
Fax +39 035 582078
E-mail: albano@isoil-impianti.it
www.isoilmeter.com

Uffici commerciali
Sales office
20092 Cinisello Balsamo (MI)
27, via F.lli Gracchi
Tel. +39 035 4239.011
Fax +39 02 66012457
E-mail: sales@isoil-impianti.it

Sede legale
Registered office
20124 Milano
24, viale Vittorio Veneto
Capitale soc. i.v. Euro 774.00
Codice fisc. E part. IVA 13066900153
C.C.I.A.A. MI – Reg. Impr. 86449/2000



C o n t e n t s

| | | |
|-------|------------------------------------|----|
| 1 | Introduction | 1 |
| 1.1 | Warranty | 1 |
| 1.2 | Introduction..... | 1 |
| 1.3 | Working principles | 1 |
| 2 | General safety principles | 3 |
| 2.1 | General instructions..... | 3 |
| 2.2 | Filter operation | 3 |
| 2.3 | Instructions for the operator..... | 4 |
| 2.4 | Servicing instructions..... | 4 |
| 2.5 | Operation precautions | 4 |
| 2.6 | Storing | 4 |
| 3 | Installation..... | 6 |
| 3.1 | Precautions | 6 |
| 3.2 | Instructions | 7 |
| 3.3 | Start-up precautions | 7 |
| 4 | Maintenance | 8 |
| 4.1.1 | Ordinary maintenance | 8 |
| 4.1.2 | Air vent valve | 8 |
| 4.2 | Extraordinary maintenance..... | 9 |
| 4.3 | Spare parts..... | 9 |
| 4.4 | Maintenance schedule..... | 9 |
| 4.5 | Troubleshooting..... | 9 |
| 5 | Technical data..... | 11 |

1 Introduction

1.1 Warranty

Each device comes with a 1-year warranty, starting from the delivering date. Such warranty of good operating of the equipments includes our efforts of repairing or replacing, in the shortest time, the parts that fail for defective manufacturing or material during the warranty period, without rights to any refund for damages or other expenses.

If a device is going to be transferred in our laboratory for repair, the delivery expenses is at the customer's expense.

For any inspection of our qualified personnel related to what stated above, the labor is at our expenses, while the board, lodging and travel expenses are in charge at the customer.

The warranty does not cover devices and parts not built by Isoil Impianti S.p.A..

The warranty ceases if non-original spare parts are used; the warranty ceases too for an improper use or if the operational limits of the device are exceeded.

1.2 Introduction

LS/AS strainers air separators are usually used to filter petroleum products or other liquids; the installation of strainer filters along the line is necessary to protect devices like PD meters, valves and other equipment from damage derived by foreign particles or crusts that may be present in the fluid flowing in the pipes.

1.3 Working principles

The liquid to be strained enters the strainer through the inlet side, passing through the inside gauge (from outside towards inside of the straining basket) and conveyed towards the outlet side.

Eventual air bags are concentrated in the upper part of the strainer being evacuated through the floating air vent valve.

Solid matters, that are settled on the bottom of the strainer, are drained through an inferior orifice



CAUTION



All parts under pressure must be released before disassembling the meter or its accessories for adjustment, inspection, servicing or substitution of its components.

Also make sure that all electric or electronic part, if present, are disconnected from its power supply.

2 General safety principles

This operator's manual contains basic safety instructions that must be followed during system installation, operation and maintenance. Failure to comply with these instructions may result in personal injury and can lead to personal, industrial or environmental accidents. Some examples of possible hazards caused by non-compliance with these instructions are:

- failure of the system and/or some components;
- hazards to people caused by the exposition to electrical, mechanical or chemical influences;
- pollution of the environment through the leaking of hazardous substances.

Therefore, follow the safety instructions described in this manual; in case of uncertainties, please contact the manufacturer.

2.1 General instructions

- Read carefully the operator's manual.
- Make sure that all the personnel assigned to the installation, operation and maintenance is properly trained.
- Make sure that the contents of the operator's manual are completely understood by all personnel assigned to the operations on the system.
- Inspect parts under pressure in compliance with national regulations before the initial operation of the system.
- Make sure that the operator's manual is readily available to personnel on site.
- Follow national safety regulation in force in the location of the plant.
- Make sure that the system operates in compliance with the relevant operational limits.
- All pressure parts must be inspected and serviced in accordance with national laws in force.

2.2 Filter operation

- The filter must be used only for the purposes it was made for; the manufacturer is not responsible for any damage resulting from failure to comply with the conditions of use.

- The filter must be operated only within the technical limits described in the operator's manual; the manufacturer is not responsible for any damage resulting from failure to comply with the operational limits.

2.3 Instructions for the operator

- The operator must adhere to safety and accident-prevention standards currently in force in the country where the device is installed.
- The operator must not, by his own initiative, carry out any operation that is outside his competence.
- The operator must carefully comply with hazard and/or prohibition instructions contained in this manual.
- Do not use petrol, solvents or other flammable substances to clean parts. Use only approved commercial solvents that are non-flammable and non-toxic.

2.4 Servicing instructions

- Never carry out any maintenance, servicing or regulation before having closed the root valve, discharged the pressure from the system and disconnected the power supply to any electrical device (if present), unless explicitly stated otherwise.
- Read carefully the rating plates on the individual equipment.
- All maintenance operations, either ordinary or extraordinary, must be done by authorised and trained personnel.
- The maintenance operator must wear clothes adequate to the working environment and to the situation; in particular, loose or voluminous clothes, chains, bracelets, rings, earrings or anything that might get caught in the mechanical parts of the system should be avoided.
- The maintenance operator must wear adequate protective devices in accordance with safety and accident-prevention regulations.
- In explosive environments use only antisparking equipment.

2.5 Operation precautions

- Follow the recommendations of the manufacturer when installing pumps. Pay particular attention to factors such as the use of foot valves, inlet pipes dimension and conformity with NPSH when there are suction pumps. Follow the recommendations of the manufacturer to minimise the problems due to air and vapours.
- For flashing liquids (quick gasification of the liquid) or easily vaporising liquids at high environmental temperatures, e.g. light hydrocarbon, it is advisable the use of submerged aspirations and pipes larger than the nominal dimension of the pump.
- Thermal expansions that generate overpressures can easily damage the meters and the systems in general. Put safety valves for overpressure in every section that can be closed through regulation or isolation valves

2.6 Storing

If the filter and its accessories are not going to be used for a long time, the following precautions must be used:

- if the filter and its accessories are unused after an operational period, drain out the product that is still inside the filter;

- close with blind flanges the inlet and the outlet of the filter, then fill it with diesel oil or with lubricating oil.



CAUTION



All parts under pressure must be released before disassembling the meter or its accessories for adjustment, inspection, servicing or substitution of its components.

Also make sure that all electric or electronic part, if present, are disconnected from its power supply.

3 Installation

3.1 Precautions

- Make sure, checking the tag marking and the rating cast on the body, that the strainer is suitable for the required service.
- The following hazards shall be considered by and are sole responsibility of the end user or installer of the strainer:
 - Extent of external loads, either applied to the body or the connections of the strainer; corrosion adequacy of the strainer material to the handled fluid; Presence of uncontrolled chemical reactions;
 - Erosion due to environmental conditions.

NOTE: All the filter's openings are protected with covers when shipped; those must not be removed until the filter is installed on the piping. If the end protections are missing or broken, the inside of the strainer must be checked for foreign objects that may have fallen inside.

- Before installation carefully inspect the strainer for possible damage during transport or handling.
- Before the installation of the filter, it is suggested to clean thoroughly the piping to remove dirt, crusts and other foreign particles.

CAUTION: The strainer air separator must always be installed upright.

- Piping should not exercise strain on the filter. The filter is designed for overhang and supports should be provided only on the adjacent pipes.
- Leave space enough around the filter to ease access for adjustment, servicing and disassembly.
- If the line pressure can reach values higher than the maximum allowed, automatic safety filters must be installed in adequate places
- It is recommended to install root valves at the inlet and outlet to ease servicing operations and isolation of the filter
- Strainers should be installed as close as possible to the machinery or valve to be protected. The arrow cast or painted on the strainer body must point to the direction of the flow.

- Install strainers with flanged ends on the pipeline using companion flanges, gaskets and fasteners corresponding to the strainer flanged ends and suitable for the fluid to be filtered.
- Make sure that all bolts and plugs are properly tightened.
- Slowly give pressure to the line, checking for leaks.
- It is recommended to perform a complete maintenance check after the start-up or whenever the pressure drop is found in excess of normal figures.

3.2 Instructions

- Remove the protecting caps on the strainer air separator
- Install the strainer/air separator; put it on place and fix it to the product line; make sure there's place enough above and below the strainer for the needed connections.

| | |
|-----------------|--|
| CAUTION: | The strainer air separator must always be installed upright. |
|-----------------|--|

- Install on the draining outlet a sphere valve and connect it with the product recovery line, if present. To ease the maintenance operations it's suggested to install sphere valves at the inlet and outlet of the filter and to the air vent valve. The air vent valve outlet must be connected to the gas recovery line.
- Connect the inlet, outlet, draining and air vent pipes to the filter
- Supply air to the pneumatic logic
- Connect the pneumatic logic to the ball valve

3.3 Start-up precautions

- Before proceeding with the start-up make sure that:
 - The filter is adequately fixed
 - All the connections are tightened
 - Air is bled from the pipes
- When the filter is operated for the first time, fill it slowly with the operating fluid by following this procedure:
 - Open slowly the upstream isolation valve or fill the filter by gravity
 - Open slowly the downstream isolation valve letting the flow rate rise smoothly to the operating value
- At the first start-up of the filter, open the line smoothly and vent out all the air eventually present in the system.



CAUTION



All parts under pressure must be released before disassembling the meter or its accessories for adjustment, inspection, servicing or substitution of its components.

Also make sure that all electric or electronic part, if present, are disconnected from its power supply.

4 Maintenance

A correct maintenance is important either for the safety of the devices and for the efficiency of the plant. Refer to the following chapters for the correct maintenance procedures.

4.1.1 Ordinary maintenance

A clean strainer is fundamental for the correct operation of the system; a dirt strainer would create an excessive pressure drop, leading to the failure of the strainer basket and thus letting dirt, crusts and other harmful elements to flow into the fluid. Check regularly the pressure drop between the inlet and the outlet of the filter; the maximum allowed pressure drop is 130 kPa.

For a correct servicing of the strainer basket, follow the procedure described below:

- Discharge the pressure from the system and close the valves at the inlet and outlet of the strainer air separator
- Discharge the liquid inside the strainer air separator through the draining outlet on the bottom of the strainer
- Remove the upper cover
- Remove the o-ring and the basket strainer
- Clean the basket strainer thoroughly with a jet directed from outside to the inside; if possible, use a water cleaning machine
- Check accurately that the strainer basket is intact; if it is found to be damaged, replace with another one with the same filtering grade:
 - For diesel oils: 60 mesh (247 micron)
 - For gasoline or water: 100 mesh (153 micron)
- Check there aren't impurity in the strainer body

4.1.2 Air vent valve

Follow the instructions below for the servicing of the air vent valve:

- Discharge the pressure from the system and close the valves at the inlet and outlet of the strainer air separator
- Discharge the liquid inside the strainer air separator through the draining outlet
- Inspect the air vent valve, checking that it works properly and its part aren't damaged

Close the draining valve.

4.2 Extraordinary maintenance

The user must define a maintenance scheduling table according to the fluid utilised, the operational conditions, the estimated/real workloads and the environmental conditions.

For all extraordinary maintenance needed after a failure and/or the rising of a fault that compromises the normal operation of the system, please contact Isoil Impianti SpA Customer Care.

4.3 Spare parts

For a correct meter maintenance use only original spare parts from Isoil Impianti S.p.A. .

Isoil Impianti S.p.A. is not responsible for any problem that can result from the use of non original spare parts.

4.4 Maintenance schedule

| Task | Monthly | 6 Months | 12 Months | 24 Months |
|--|---------|----------|-----------|-----------|
| Check for excessive pressure drop through the filter | X | | | |
| Visual inspection of air vent valve | | X | | |
| Check and cleaning of strainer basket | | | X | |

4.5 Troubleshooting

| Symptom | Possible cause | Remedy |
|--|---|---|
| Liquid passing with normal flow rate but counter fails to register. | 1. Defective counter. | Remove and check the counter by rotating bottom coupling. In case of any problem in the counter, contact the factory. |
| | The pump is off | Turn on the pump. |
| Fluid does not flow through the meter; there is pressure at the strainer inlet | The valve downstream the strainer is closed | Open the valve. |
| | Pump head too low | Check that the pump head is adequate for the plant. |
| | Wire gauze too dirt | Clean the strainer basket; (chap.4.1.1) |
| Foreign particles present in the fluid | Wire gauze damaged | Check and replace the strainer basket; (chap.4.1.1) |
| Excessive presence of air in | Problems in the line: presence | Check accurately the pipings ant |

| Symptom | Possible cause | Remedy |
|--|--|---|
| the line | of air is usually symptom of some problems along the line. | the pumps to locate possible point where the air is suctioned. |
| | Air vent valve damaged | Check the air vent valve and replace it if damaged. (chap.4.1.2.) |
| Product leakage through the air vent valve | The valve does not close correctly | Check the air vent valve, with particular attention to the gaskets and the leverages. |

5 Technical data

- Max. working pressure: 1000 kPa
- Temperature range: -10°C - +50°C
- Max flow 1300 l/min

The value reproduced in label can change as regards to those shown in the manual

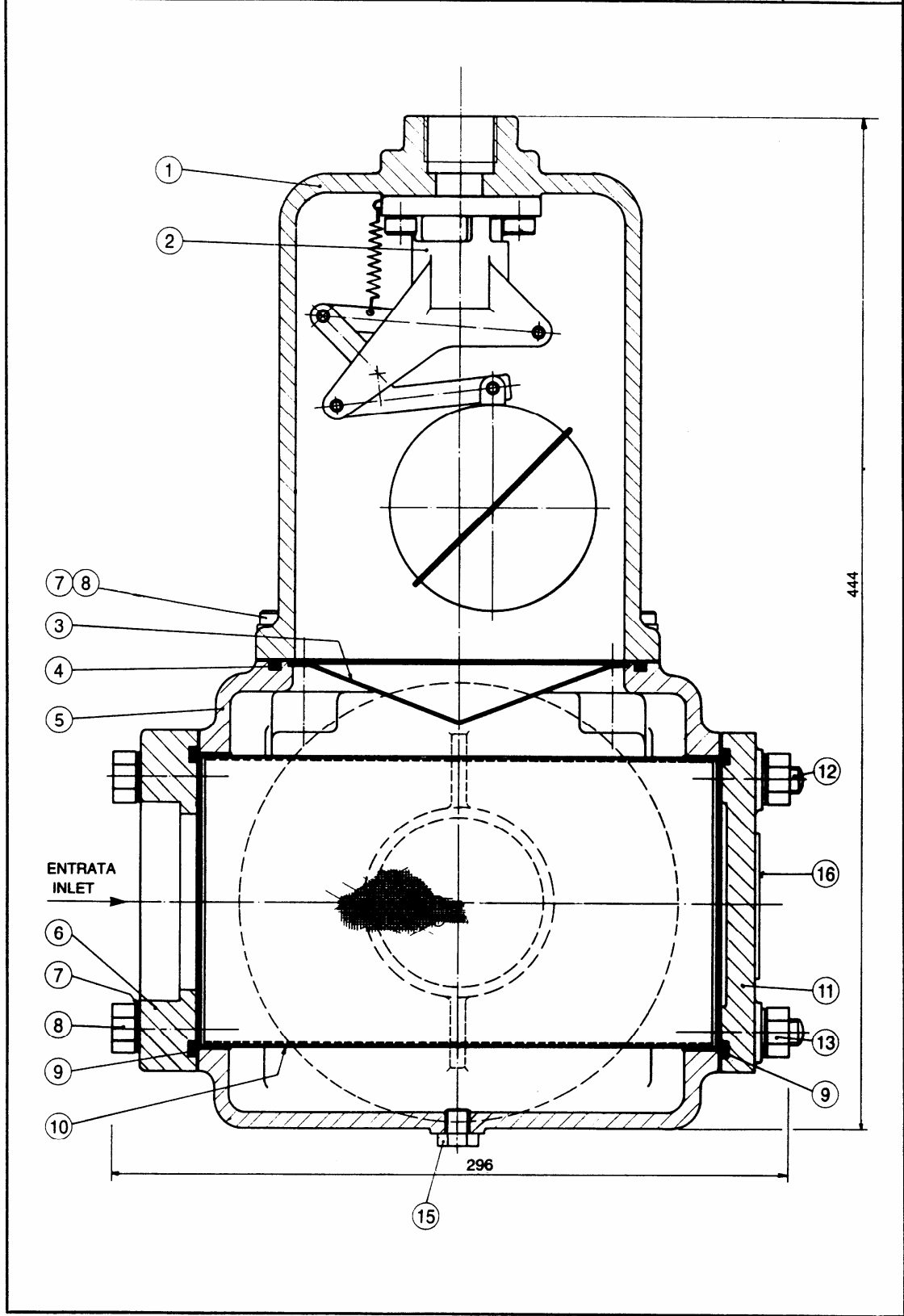

N° 4 VITI/SCREWS TCEI M 8x20 COD.80VI4201

N° 4 RONDELLE/WASHERS Ø8 COD. 80R01207

(*) GUARNIZIONE/GASKET VITON COD. 80GU0171

(*) GUARNIZIONE/GASKET TEFLON COD. 80GU0168

(*) PISTONE/PISTON BRONZE COD. 80PI7012

(*) PISTONE/PISTON INOX COD. 80PI7015

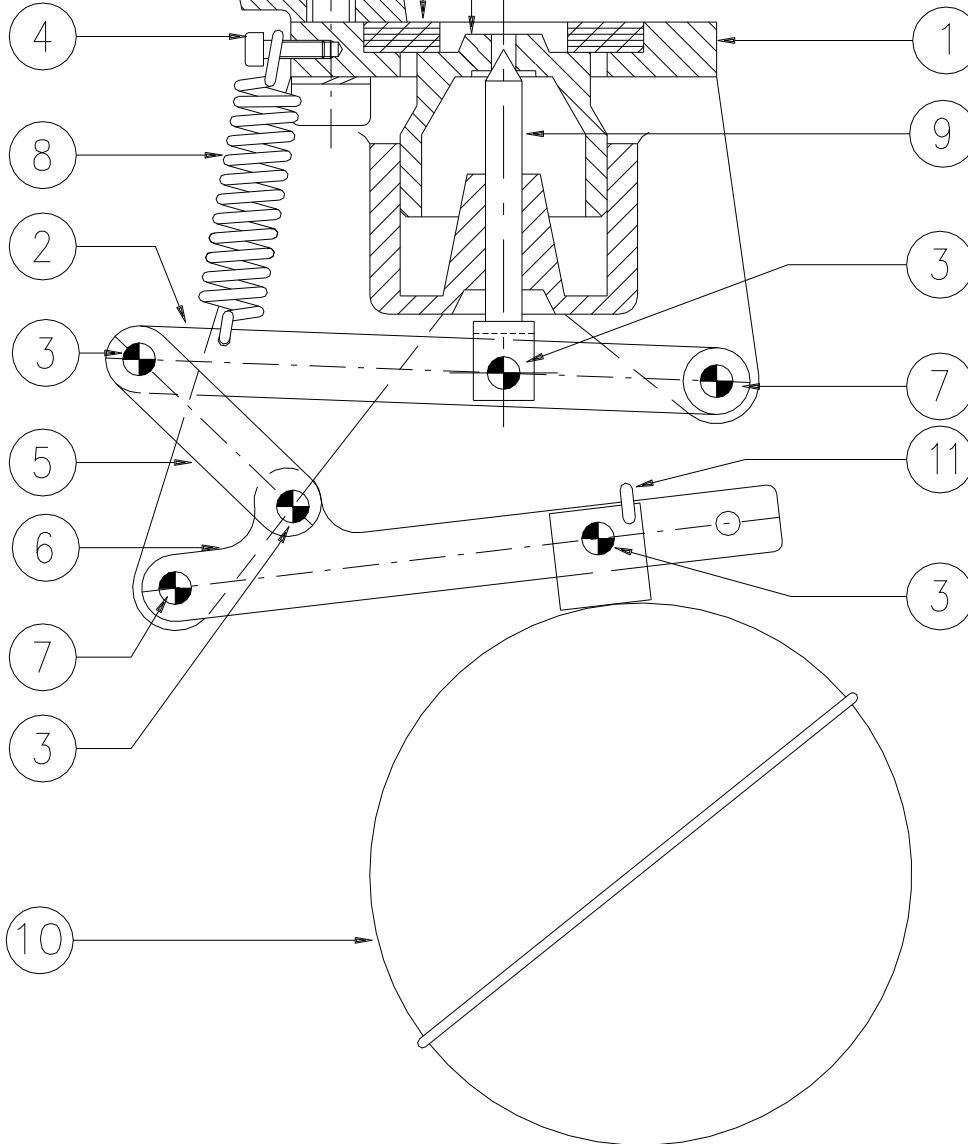

ASSIEME VALVOLA DEGASATRICE DIS. 565 GALLEGGIANTE Ø90 { COD. 80VA4021
VALVE ASSEMBLY FLOAT Ø90

ASSIEME VALVOLA DEGASATRICE DIS. 565 GALLEGGIANTE Ø110 { COD. 80VA4024
VALVE ASSEMBLY FLOAT Ø110

* PARTI DI RICAMBIO CONSIGLIATE /SUGGESTED SPARE PARTS

