

OPERATOR'S MANUAL

P.D. METER TYPE SBM 150

CODE:	MA/027/00/EN
REV:	06
DATED:	04/2007

ISOIL IMPIANTI S.p.A. – Italy

Sede e Stabilimento
Head office and factory
24061 Albano S. Alessandro (BG)
74, via Madonna delle Rose
Tel. +39 035 4239.011
Fax +39 035 582078
E-mail: albano@isoil-impianti.it
www.isoilmeter.com

Uffici commerciali
Sales office
20092 Cinisello Balsamo (MI)
27, via F.lli Gracchi
Tel. +39 035 4239.011
Fax +39 02 66012457
E-mail: sales@isoil-impianti.it

Sede legale
Registered office
20124 Milano
24, viale Vittorio Veneto
Capitale soc. i.v. Euro 774.00
Codice fisc. E part. IVA 13066900153
C.C.I.A.A. MI – Reg. Impr. 86449/2000



C o n t e n t s

1	Introduction	1
1.1	Warranty	1
1.2	Introduction	1
1.3	Working principles	1
2	General safety principles	3
2.1	General instructions	3
2.2	Meter operation	3
2.3	Instructions for the operator	4
2.4	Servicing instructions	4
2.5	Operation precautions	4
3	Installation	6
3.1	Precautions	6
3.2	Start-up precautions	7
4	Maintenance	8
4.1	Disassembly	8
4.1.1	Main components disassembling	8
4.1.2	Rotor disassembling	9
4.2	Assembly	9
4.3	Storing	9
4.4	Calibrating mechanism	9
4.4.1	Calibration of flow meter	9
4.4.2	Suggested lubricating oils for calibrating mechanism	10
4.5	Tests after overhaul	11
4.6	Extraordinary maintenance	11
4.7	Spare parts	11
4.8	Maintenance schedule	11
4.9	Troubleshooting	11
5	Technical data	13
6	Special tools	13

Allegati

- P.D. meter SBM150 CFPVp+check Dis. 5559/M
- P.D. meter assembly with lip seal Dis.6756M
- Vane assembly Dis.758
- Strainer air separator Dis.570
- Air vent valve Dis. 565-M
- Preset Valve Dis.705/3
- Air check valve Dis. 735
- Calibration mechanism Dis. 672
- Gearing box for mounting of electronic counter Vega Dis. 3958

1 Introduction

1.1 Warranty

Each device comes with a 1-year warranty, starting from the delivering date. Such warranty of good operating of the equipments includes our efforts of repairing or replacing, in the shortest time, the parts that fail for defective manufacturing or material during the warranty period, without rights to any refund for damages or other expenses.

If a device is going to be transferred in our laboratory for repair, the delivery expenses is at the customer's expense.

For any inspection of our qualified personnel related to what stated above, the labor is at our expenses, while the board, lodging and travel expenses are in charge at the customer.

The warranty does not cover devices and parts not built by Isoil Impianti S.p.A..

The warranty ceases if non-original spare parts are used; the warranty ceases too for an improper use or if the operational limits of the device are exceeded.

1.2 Introduction

ISOIL positive displacement meters are precision measuring instruments designed for use with a variety of petrochemical products and liquids. Each meter is fully tested and calibrated by factory before dispatch, and a regular service will maintain a high standard of performance and accuracy.

P.D. meters must be periodically tested by a calibrating tank, Prover, or Master Meter: if out of accuracy a service is necessary.

Experience has shown that mechanical defects are usually caused by the entry of foreign matters into the metering compartment due to inadequate straining facilities in the pipeline.

Special tools have been designed to facilitate overhaul operations and their use is recommended. Reference to the tools is included in the next pages (see chap.5).



Figura 1

1.3 Working principles

Liquid enters the meter through the manifold and causes the rotor to revolve by pressure on the vanes. The proximity of the rotor to the front and rear of the casing forms an efficient seal while the profile of the casing guides the vanes on to the measuring crescent.

The seal between vane and body is assured by the combined effects of gravity and centrifugal forces of vanes and it is assured the self-balance of clearances generated by the use too.

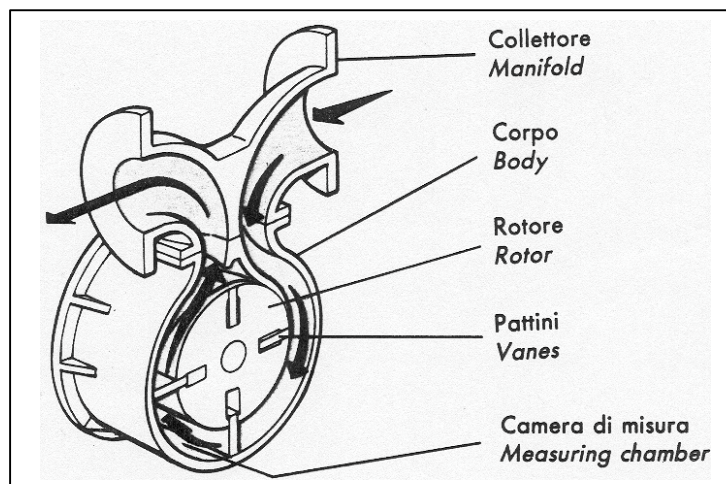
The rotor spindle extends through a pressure tight seal in the meter front cover into the calibrating mechanism which transmits the rotor movement to the register.



CAUTION



All parts under pressure must be released before disassembling the meter or its accessories for adjustment, inspection, servicing or substitution of its components.

Also make sure that all electric or electronic part, if present, are disconnected from its power supply.

2 General safety principles

This operator's manual contains basic safety instructions that must be followed during system installation, operation and maintenance. Failure to comply with these instructions may result in personal injury and can lead to personal, industrial or environmental accidents. Some examples of possible hazards caused by non-compliance with these instructions are:

- Failure of the system and/or some components
- Hazards to people caused by the exposition to electrical, mechanical or chemical influences
- Pollution of the environment through the leaking of hazardous substances

Therefore, follow the safety instructions described in this manual; in case of uncertainties, please contact the manufacturer.

2.1 General instructions

- Read carefully the operator's manual
- Make sure that all the personnel assigned to the installation, operation and maintenance is properly trained
- Make sure that the contents of the operator's manual are completely understood by all personnel assigned to the operations on the system
- Inspect parts under pressure in compliance with national regulations before the initial operation of the system
- Make sure that the operator's manual is readily available to personnel on site
- Follow national safety regulation in force in the location of the plant
- Make sure that the system operates in compliance with the relevant operational limits
- All pressure parts must be inspected and serviced in accordance with national laws in force

2.2 Meter operation

- The meter must be operated exclusively by the personnel trained and authorised to its operation

- The meter must not be operated in presence of foreign, unauthorised or not adequately trained personnel
- The meter must be used only for the purposes it was made for; the manufacturer is not responsible for any damage resulting from failure to comply with the conditions of use
- The meter must be operated only within the technical limits described in the operator's manual; the manufacturer is not responsible for any damage resulting from failure to comply with the operational limits

2.3 Instructions for the operator

- The operator must adhere to safety and accident-prevention standards currently in force in the country where the device is installed
- The operator must not, by his own initiative, carry out any operation that is outside his competence
- The operator must carefully comply with hazard and/or prohibition instructions contained in this manual
- Do not use petrol, solvents or other flammable substances to clean parts. Use only approved commercial solvents that are non-flammable and non-toxic

2.4 Servicing instructions

- Never carry out any maintenance, servicing or regulation before having closed the root valve, discharged the pressure from the system and disconnected the power supply to any electrical device (if present), unless explicitly stated otherwise.
- Read carefully the rating plates on the individual equipment
- All maintenance operations, either ordinary or extraordinary, must be done by authorised and trained personnel
- The maintenance operator must wear clothes adequate to the working environment and to the situation; in particular, loose or voluminous clothes, chains, bracelets, rings, earrings or anything that might get caught in the mechanical parts of the system should be avoided
- The maintenance operator must wear adequate protective devices in accordance with safety and accident-prevention regulations
- In explosive environments use only antisparking equipment
- If the meter is connected to any electric or electronic equipment, disconnect all of them from the power supply before doing any servicing or regulation operation, unless explicitly stated otherwise in the manual

2.5 Operation precautions

- The meter must always remain full of product; to achieve this, it is suggested to install the meter so that it remains below the main line
- The line upstream the meter must be kept full of product to avoid that some air enters the meter
- Each meter must be adjusted following the instructions supplied in the operator's manual
- Follow the recommendations of the manufacturer when installing pumps. Pay particular attention to factors such as the use of foot valves, inlet pipes dimension and conformity with NPSH when there are suction pumps. Follow the recommendations of the manufacturer to minimise the problems due to air and vapours.

- For flashing liquids (quick gasification of the liquid) or easily vaporising liquids at high environmental temperatures, e.g. light hydrocarbon, it is advisable the use of submerged aspirations and pipes larger than the nominal dimension of the pump.
- Thermal expansions that generate overpressures can easily damage the meters and the systems in general. Put safety valves for overpressure in every section that can be closed through regulation or isolation valves



CAUTION



All parts under pressure must be released before disassembling the meter or its accessories for adjustment, inspection, servicing or substitution of its components.

Also make sure that all electric or electronic part, if present, are disconnected from its power supply.

3 Installation

3.1 Precautions

The installation of the meter counter does not require any special procedure; just pay attention to the following points:

- The meter counter must be installed horizontally; for other applications a vertical arrangement is provided. In both cases the rotor axis must be kept horizontal.
- All the meter's openings are protected with covers when shipped; those must not be removed until the meter is installed on the piping
- Before the installation of the meter, it's suggested to clean thoroughly the piping to remove dirt, crusts and other foreign particles.
- Piping should not exercise strain on the meter. The meter is designed for overhang and supports should be provided only on the adjacent pipes.
- Leave space enough around the meter to ease access for adjustment, servicing and disassembly. The counter, if present, must be easily readable.
- The meter must always remain full of product; it's suggested to install the meter so that it remains always under the main line.
- The line upstream the meter must always remain full of product to avoid that air enters the meter's measure chamber; if the pipe arrangement allows reversal flow, a non-return valve must be installed.
- Flow through the meter must be regular and uniform; pulsating and irregular flows must be avoided.
- It is recommended to install flow limiting valves downstream of the meter if the flow rate can reach values higher than the maximum allowed for the meter.
- If the line pressure can reach values higher than the maximum allowed, automatic safety valves must be installed in adequate places.
- To protect meter from damages due to foreign particles in the liquid, a suitable strainer with a correct mesh number (40 mesh for oil, 60 mesh for diesel oil, 100 mesh for gasoline) must be installed upstream the meter.
- In case the rate of flow through the installation exceeds the meter maximum rated capacity, it is advisable to use a flow limiting valve, which must be installed downstream the same meter.

- Water must not flow through the meter.
- Meters must be installed in such a way that air or vapour do not enter through the liquid under measurement. It is always suggested to install an air separator just upstream the meter.
- To avoid hammer shocks which may strongly damages the meter, it is not advisable to install upstream or downstream the meter any quick closing valves.
- It is recommended to install root valves at the inlet and outlet to ease servicing operations and isolation of the meter

3.2 Start-up precautions

- Before proceeding with the start-up make sure that:
 - The meter is adequately fixed
 - All the connections are tightened
 - Air is bled from the pipes
- If a calibration mechanism is associated with the meter, before the start-up it must be filled with lubricating oil
- Vent out all the air eventually present in the line
- When the meter is operated for the first time, fill it slowly with the operating fluid by following this procedure:
 - Open slowly the upstream isolation meter or fill the meter by gravity
 - Open slowly the downstream isolation meter letting the flow rate rise smoothly to the operating value



CAUTION



Be very careful when starting up the meter: if the air enters the measuring chamber the rotor can easily reach high rotational speeds, leading to abnormal wear of the vanes and other components; this, in turn, will lead the meter to a major failure.



CAUTION



All parts under pressure must be released before disassembling the meter or its accessories for adjustment, inspection, servicing or substitution of its components.

Also make sure that all electric or electronic part, if present, are disconnected from its power supply.

4 Maintenance

Before removing the flow meter from the pipeline for repairs, it is recommended that the possible causes and corrective actions are noted with the help of Fault Diagnosis Chart given in this manual.

Note that certain components in the flow meter assembly are not interchangeable. Therefore, if more than one flow meter is dismantled, it is recommended that each flow meter is dismantled independently.

CAUTION: Be very careful when you start up the meter after maintenance: if the air enters the measuring chamber the rotor can easily reach high rotational speeds, leading to abnormal wear of the vanes and other components; this, in turn, will lead the meter to a major failure. See chap.3.2 for start-up procedures.

4.1 Disassembly

The SBM150 flow meter may be considered as two main assemblies: the measuring chamber and the calibrating mechanism. To separate these two assemblies from each other, remove the screws securing the calibrating mechanism on the flow meter body.

CAUTION: Before dismantling the meter for maintenance release pressure from the line and drain all the fluid inside the meter through the draining hole below the meter.

Proceed then with the maintenance of the faulty part.

4.1.1 Main components disassembling

- To ensure stability during the dismantling, it is advisable to use our "Ring Support tool" (see special tool).
- Remove the sealings and the screws of the counter, unscrew the screws fixing the calibrating mechanism and after the removal of the transmission spindle, take off the transmission spindle pin.
- Remove all nuts, bolts and washers of the front cover.
- Remove the front cover using the "Cover Removal Tool" (see special tool).
- Remove the rotor group by using the "Rotor removal and turning tool" (see special tool). Turn the rotor so that two graphite vanes re-enter in the rotor in correspondence of the smaller radius.

- Extract the rotor paying attention to use the free hand to guide the rotor and control the lateral vanes movement.

4.1.2 Rotor disassembling

NOTE: Never remove the vanes unless they are damaged. If it is necessary to remove the vanes, before proceeding mark the position of the four vanes that correspond with the position in the rotor: that will ease the reassembly procedure. Vanes are not interchangeable and, if they can be reused, they must be placed in their original position.

- Remove the split pin placed in the opposite side of the adjusting screws
- Remove the vane and the two washers
- Remove the remaining vane-rods assembly

CAUTION: Don't remove or loosen the the vanes adjusting nuts, since that would vary the clearance between the vanes and the measuring chamber, causing loss of performance and/or meter failure.

4.2 Assembly

Before assembly, clean and inspect all parts for any visual damage. Ensure that all o-ring grooves are clean and undamaged. Examine the O-Rings and ensure that they are not damaged or swollen, replace them if necessary. Examine graphite bushes on rotor assembly for free rotation and play, replace them if either is apparent. Examine each vane assembly for damage or wear, replace vane(s) if either is apparent. Examine gland seal rings in rotor assembly for damage or wear and replace if either is apparent.

The assembly procedure is the reversal of the dismantling procedure; only for installation of the internal body special precautions should be taken to match the centering cap of the external body's front cover.

4.3 Storing

- if after a working period it is foreseen to stop the meter for a long time, drain the meter and its accessories;
- If the meter or the equipment of the system are not immediately used, or if it is withdrawn from service and stored, it is important to follow next instructions :
 - fill the meter and its accessories with clean kerosene or lubricated oil and close its ends with blind flanges;
 - fill the carter containing the calibrating mechanism with oil till the sight glass is reached (see chap.4.4)
- adequately protect counters against rain and dust, with damp-proof caps

4.4 Calibrating mechanism

The calibrating mechanism comprises a train of gears which transmit movement of the rotor to the counter. Operational failures of the mechanism are rare and they generally regard the breaking of tension pin, due to an excessive strain.

It is recommended to repair without varying the calibrating adjustment.

CAUTION: do not remove the shimming washers between the frame and the bearing of the mechanism box.

4.4.1 Calibration of flow meter

To carry out meter calibration follow next procedures:

- Break and remove seals.
- Remove the three screws (1) securing the cover (2) to the housing (3) in which calibrating mechanism is fitted.
- Remove cover (2)
- By using square key (4 mm) turn shaft (4) till A, B, C holes placed on the bracket (5) and on friction roller (6) will be properly aligned.
- Insert in these holes the stop pin (supplied with the meter, then using the square key operate on the shaft (4) as follow :
 - turning anticlockwise direction, even if the quantity of fluid does not vary, on the counter is obtained an higher volume indication;
 - turning clockwise direction it is obtained a lesser indication.

NOTE: one complete turn of the screw varies the volume indicated on the meter by approximately 0,18% (per cent).

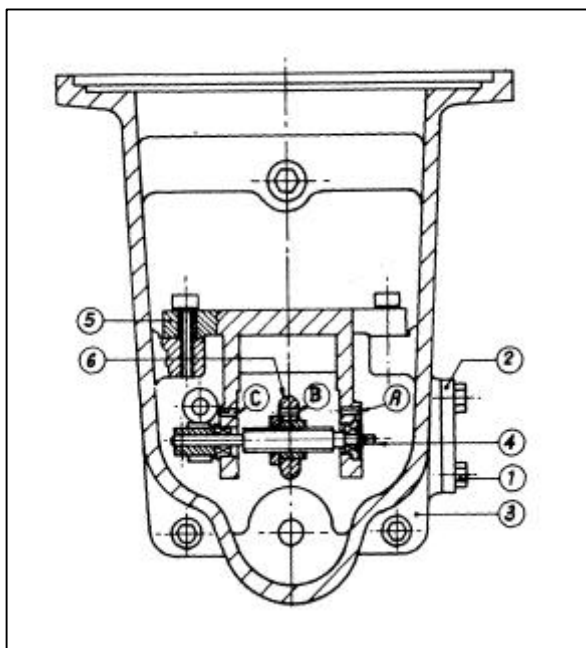

Figure 2

4.4.2 Suggested lubricating oils for calibrating mechanism

Company	Type	Temperature range
AGIP	OTE 32 SINT 2000	-10÷+60 °C
ESSO	NUTO 32	-20÷+65 °C
IP	HINDRUS HI 46	-10÷+60 °C
SHELL	AEROSHELL FLUID 31	-40÷+204°C
MOBIL	DTE 26 MOBIL 1	-10÷+80 °C -10÷+200 °C

NOTE: to avoid ice forming in wintertime, add two spoons of car antifreeze.

4.5 Tests after overhaul

After overhaul the p.d. meters must be tested with suitable proving systems. Error between the value stated by the p.d.meter counter and the value stated by the proving device is calculated as below:

Example:

Measured by the meter	Measured by the proving tank	Error (%)
1000 l	1003 l	-0,3%
1000 l	997 l	+0,3%

The formula is:

$$E\% = \frac{V - V_0}{V_0} \cdot 100$$

V= Measured by the meter

V₀= Measured by the proving tank

4.6 Extraordinary maintenance

The user must define a maintenance scheduling table according to the fluid utilised, the operational conditions, the estimated/real workloads and the environmental conditions.

For all extraordinary maintenance needed after a failure and/or the rising of a fault that compromises the normal operation of the system, please contact Isoil Impianti SpA Customer Care.

4.7 Spare parts

For a correct meter maintenance use only original spare parts from Isoil Impianti S.p.A. .

Isoil Impianti S.p.A. is not responsible for any problem that can result from the use of non original spare parts.

4.8 Maintenance schedule

Task	Monthly	6 Months	12 Months	24 Months
Visual inspection of manifold and meter body; check for leaks	X			
Inspection of the meter; check for internal part status: vanes, rotor, measure chamber, o-rings; check for wear or damage.				X

4.9 Troubleshooting

Symptom	Possible cause	Remedy
Liquid passing with normal flow rate but counter fails to register.	1. Defective counter.	Remove and check the counter by rotating bottom coupling. In case of any problem in the counter, contact the factory.
	2. Drive from the rotor fails to reach the counter, due to sheared pins in the calibrating mechanism.	Check cross pins fitted on all gears in the calibrating mechanism.
No liquid passing through.	1. Defective counter.	Remove and inspect the counter for free movement.
	2. Jammed calibrating mechanism.	Remove and inspect the calibrating mechanism. Identify the source of friction and replace relevant parts.
	3. Jammed rotor assembly.	Dismantle meter assembly. Inspect front & rear covers and rotor for scoring marks. Inspect vanes and bearings for damage.
	Causes of rotor jamming :	
	a. Solid particles trapped on rotor surface.	Clean the rotor surfaces.
	b. Incorrect adjustment of rotor end clearance due to loose or defective bearing adjuster.	Check setting of bearing adjuster. Clean and inspect the bearing adjuster.
	c. Rotor bearings jammed.	Clean bearings and cover, and inspect for any damage.
	d. Rotor bearings worn out.	Replace the bearings, if axial play is observed.
	e. Misalignment of front & rear covers due to missing dowel pins.	Ensure that both dowel pins are used for locating the covers with the body.
	4. Clogged filter basket.	Clean the filter regularly.
Liquid is leaking from the joint at front cover and calibrating mechanism.	Spindle seal is damaged.	Replace the spindle seal. Inspect rotor spindle for wear or scratch marks.
Liquid is leaking from the joint at front cover and body or rear cover and body.	Damaged o'ring seals, unclean o'ring grooves, cover bolts loose.	Clean o'ring grooves, replace o'rings and secure cover bolts tightly.
Excess delivery beyond 1%.	1. Vane blades damaged.	Inspect and replace damaged vane blades.
	2. Jammed rotor or calibrating mechanism.	As described above.

5 Special tools

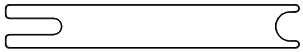
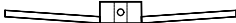
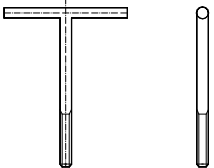
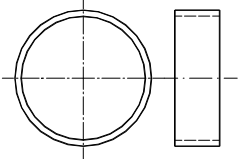
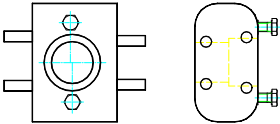
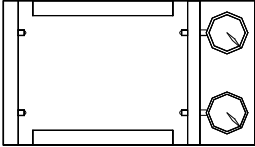
DESCRIPTION	USE	FIGURE
Spring compression tool Special spanner (Two pieces are necessary) Code 80AT0036	For compressing vane spring when assembling or dismantling split pins. To tight adjusting nuts during adjusting length of vane assy.	 <p style="text-align: right;">A</p>
Rotor removal and turning tool Code 80AT0039	To fit on the rotor spindle in place of rotor gear when turning or removing rotor assembly	 <p style="text-align: right;">B</p>
Cover removal tool (n.2 pieces are necessary) Code 80AT0042	For extracting front cover.	 <p style="text-align: right;">C</p>
Ring support tool Code 80AT0048	For supporting bulkmeter during dismantling and re-assembly	 <p style="text-align: right;">E</p>
Bearings extractor Code 80ES0012	For dismantling the internal ring of the bearing after having broken the external ring.	 <p style="text-align: right;">E</p>
Vanes checking tool Code 80AT0057	For measuring of the vanes length.	 <p style="text-align: right;">F</p>

6 Technical data

- Type: Positive displacement meter counter
- Max. working pressure: 1000 kPa
- Temperature range: -10°C - +50°C
- Flow rate: 130-1300 lpm

The value reproduced in label can change as regards to those shown in the manual

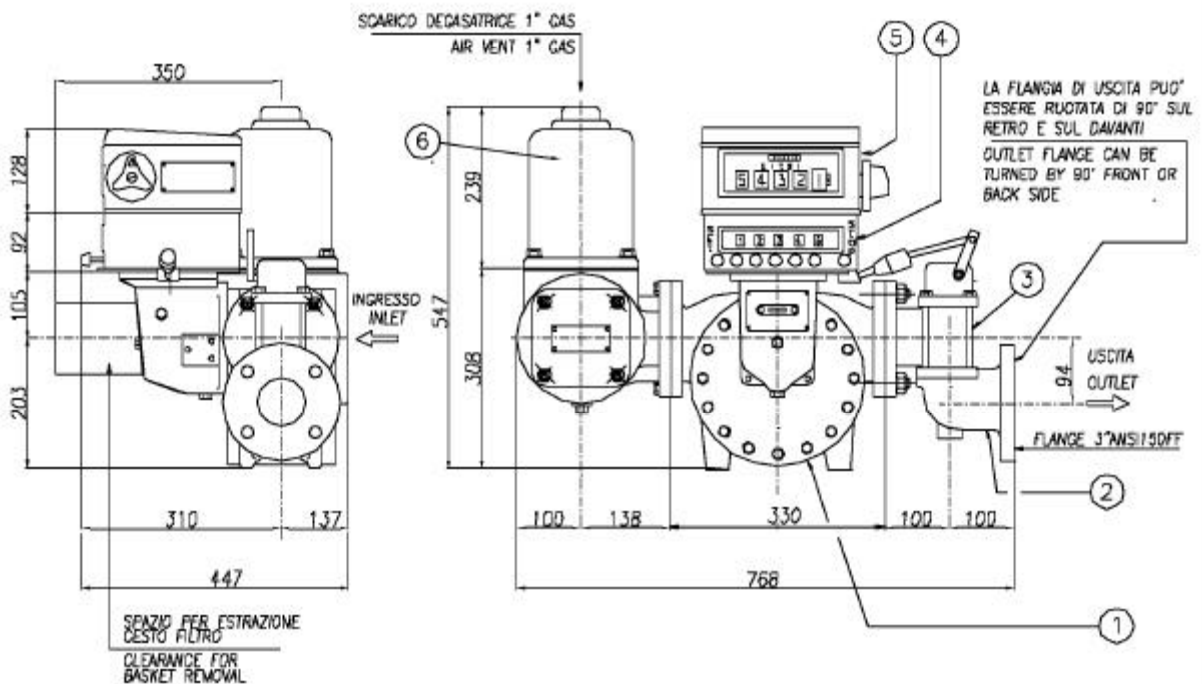

- | | | |
|-----------------------|---|------------------------|
| 1 CONTATORE SBM150 | - | P.D.METER SBM150 |
| 2 VALVOLA CHECK | - | CHECK VALVE |
| 3 VALVOLA PRESET | - | PRESET VALVE |
| 4 PREDETERMINATORE | - | PRESET REGISTER |
| 5 TESTATA INDICATRICE | - | COUNTER |
| 6 FILTRO DEGASATORE | - | STRAINER AIR SEPARATOR |

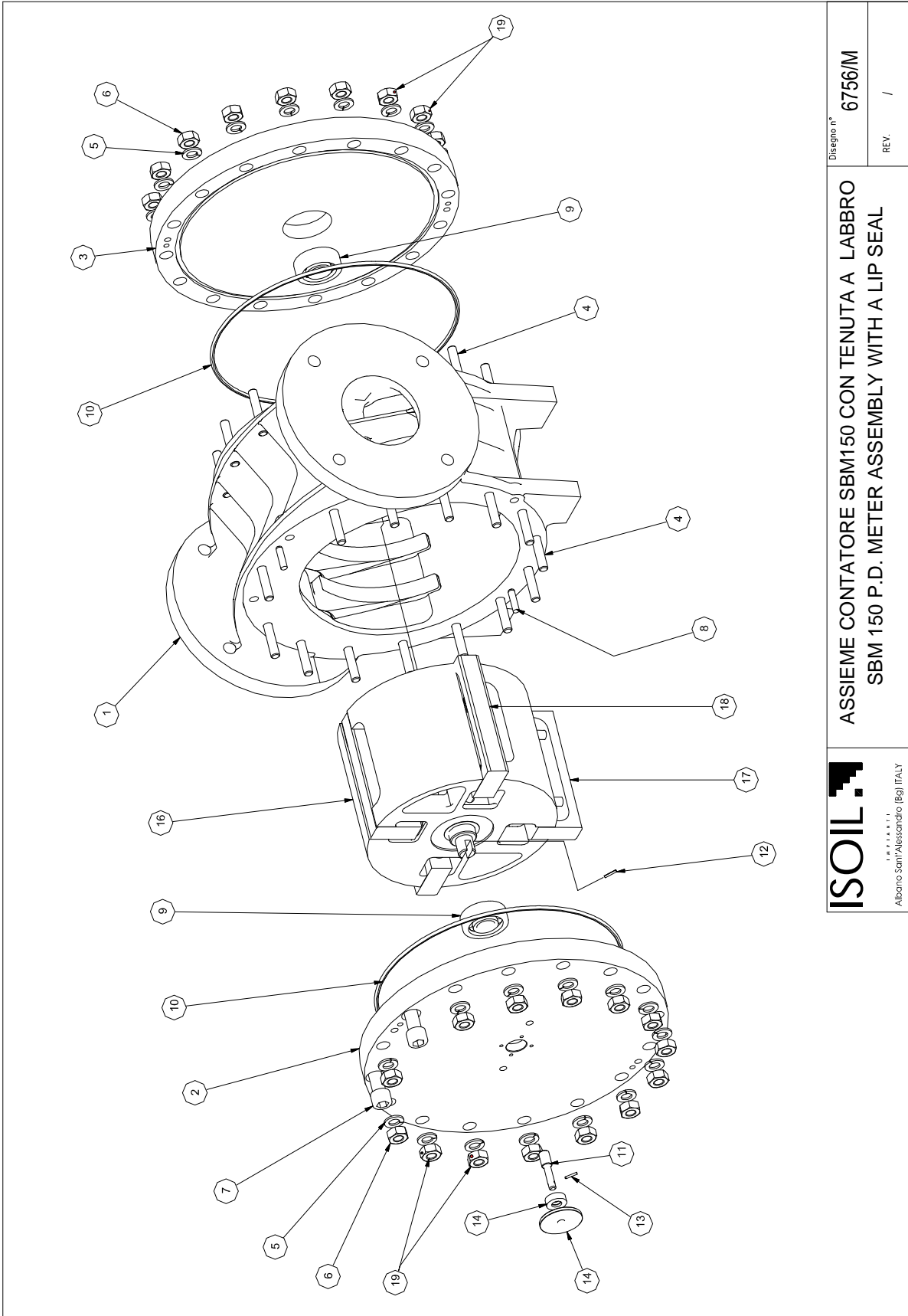

Disegno n° 6756/M

REV. /

ASSIEME CONTATORE SBM150 CON TENUTA A LABBRO
 SBM 150 P.D. METER ASSEMBLY WITH A LIP SEAL



Albano Sant'Alessandro (Bg) ITALY

ISOIL IMPIANTI		ASSIEME CONTATORE SBM 150 CON TENUTA A LABBRO SBM 150 P.D. METER ASSEMBLY WITH LIP SEAL						Dis. 6756/M	
								Foglio 1 di 1	
pos. item	N° CODICE N° CODE	DESCRIZIONE DESCRIPTION	Q.tà Q.ty	MATERIALE MATERIAL	pos. item	N° CODICE N° CODE	DESCRIZIONE DESCRIPTION	Q.tà Q.ty	MATERIALE MATERIAL
1	80COG063	Corpo Body	1	Alluminio Aluminium					
2	80COB072	Coperchio anteriore Front cover	1	Acc. al carb. Carbon steel					
3	80COB339	Coperchio posteriore Rear cover	1	Acc. al carb. Carbon steel					
4	80PR3075	Prigioniero Stud	30	Acc. al carb. Carbon steel					
5	80RO1180	Rondella Washer	30	Acc. al carb. Carbon steel					
6	80DA1018	Dado Nut	25	Acc. al carb. Carbon steel					
7	80VI4267	Vite Screw	2	Acc. al carb. Carbon steel					
8	80SP6021	Spina cilindrica Dowel pin	4	Acc. al carb. St. steel					
9*	80CU1100	Cuscinetto Bearing	2	Acc. inox Carbon steel					
10*	80GU1630	Guarnizione OR seal	2	Nitrile Nitrile					
10*	80GU1627	Guarnizione OR seal	2	Viton Vitonl					
11	80AL0293	Alberino rotore Rotor spindle	1	Acc.inox St. steel					
12	80SP5033	Spina spirol Spirol pin	1	Acc. al carb. Carbon steel					
13	80SP5009	Spina spirol Spirol pin	1	Acc. al carb. Carbon steel					
14*	80KI0135	Kit BM 36/1 Kit BM 36/1	1	Viton Viton					
16	80RO2078	Rotore Rotor	1	Alluminio Alluminium					
17*	80COC075	Coppia pattini sx Left vanes couple	1	Grafite Graphite					
18*	80COC045	Coppia pattini dx Right vanes couple	1	Grafite Graphite					
19	80DA1006	Dado Nut	4	Acc. al carb. Carbon steel					
					*	Parti di ricambio consigliate / Suggested spare parts			

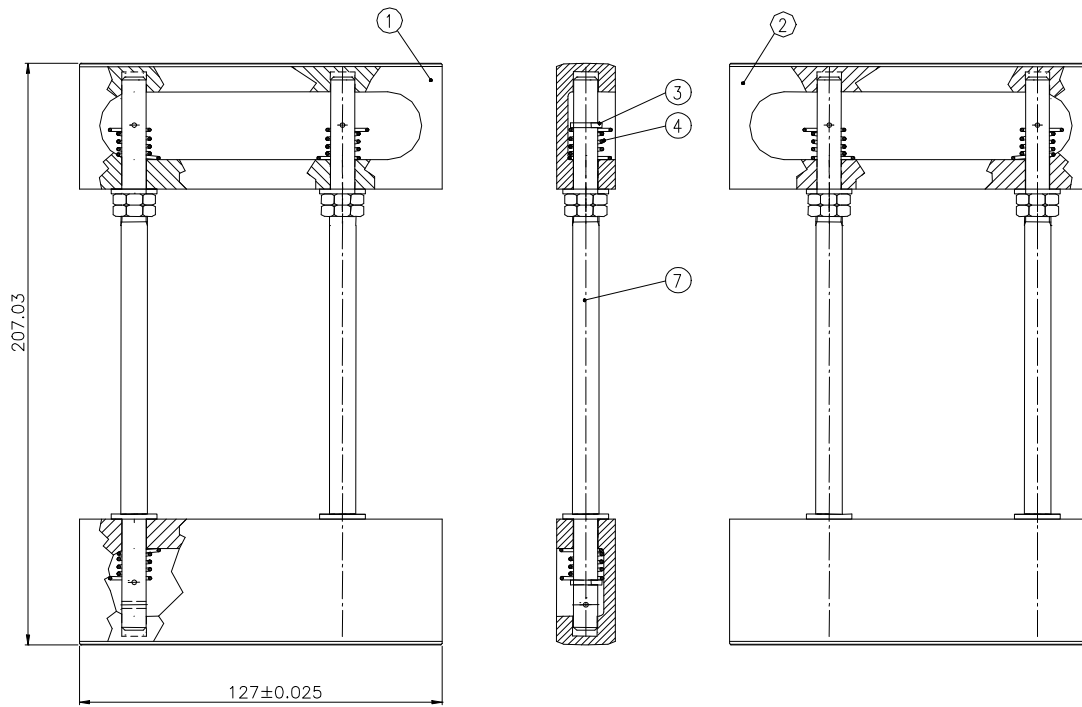

COPPIA PATTINI SINISTRI
LEFT VANES COUPLE
COD. 80COC075

COPPIA PATTINI DESTRI
RIGHT VANES COUPLE
COD. 80COC045

pos. item	N° CODICE N° CODE	DESCRIZIONE DESCRIPTION	Q.tà Q.ty	MATERIALE MATERIAL	pos. item	N° CODICE N° CODE	DESCRIZIONE DESCRIPTION	Q.tà Q.ty	MATERIAL
1	80PA1075	Pattino sinistro Left vane	4	Grafite Graphite					
2	80PA1012	Pattino destro Right vane	4	Grafite Graphite					
3	80COD009	Coppiglia Cotter pin	16	Acc. inox St. steel					
4	80MO0216	Molla Spring	16	Acc. inox St. steel					
7	80AS0093	Assieme tirante Rod assembly	8	Acc. inox St. steel					

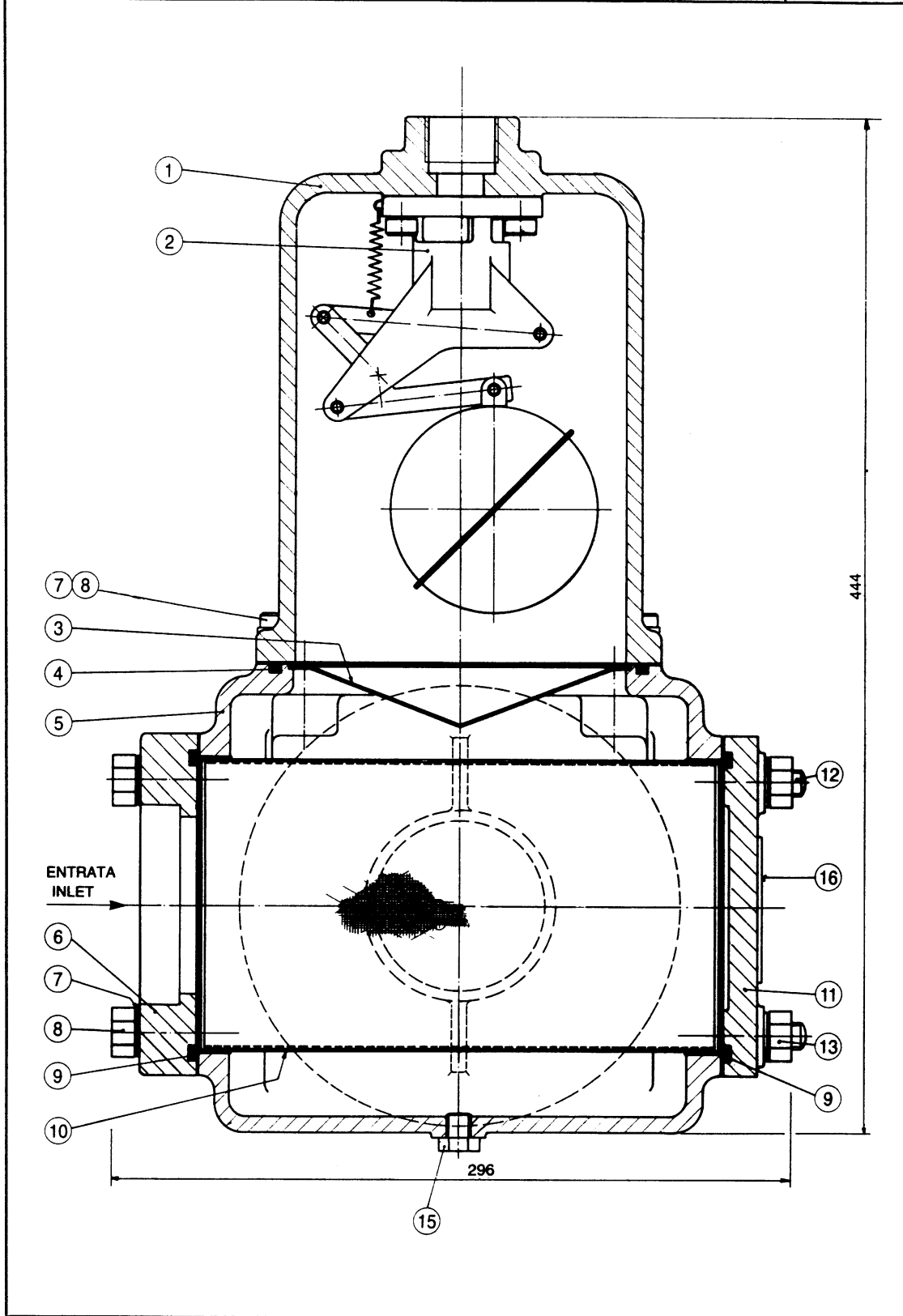

N° 4 VITI/SCREWS TCEI M 8x20 COD.80VI4201

N° 4 RONDELLE/WASHERS Ø8 COD. 80R01207

(*) GUARNIZIONE/GASKET VITON COD. 80GU0171

(*) GUARNIZIONE/GASKET TEFLON COD. 80GU0168

(*) PISTONE/PISTON BRONZE COD. 80PI7012

(*) PISTONE/PISTON INOX COD. 80PI7015

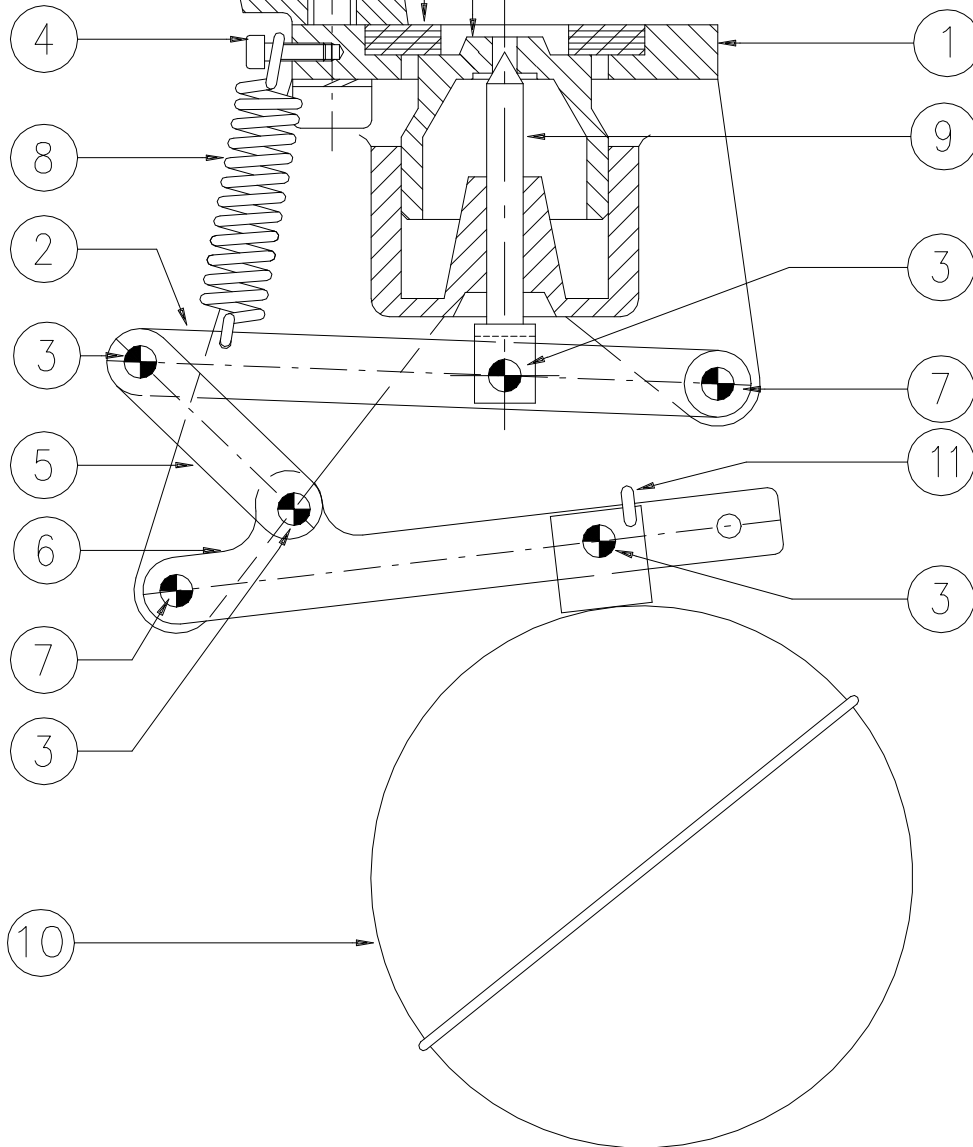

ASSIEME VALVOLA DEGASATRICE DIS. 565 GALLEGGIANTE Ø90 VALVE ASSEMBLY FLOAT Ø90	{ COD. 80VA4021 COD. 80VA4024
ASSIEME VALVOLA DEGASATRICE DIS. 565 GALLEGGIANTE Ø110 VALVE ASSEMBLY FLOAT Ø110	

* PARTI DI RICAMBIO CONSIGLATE /SUGGESTED SPARE PARTS

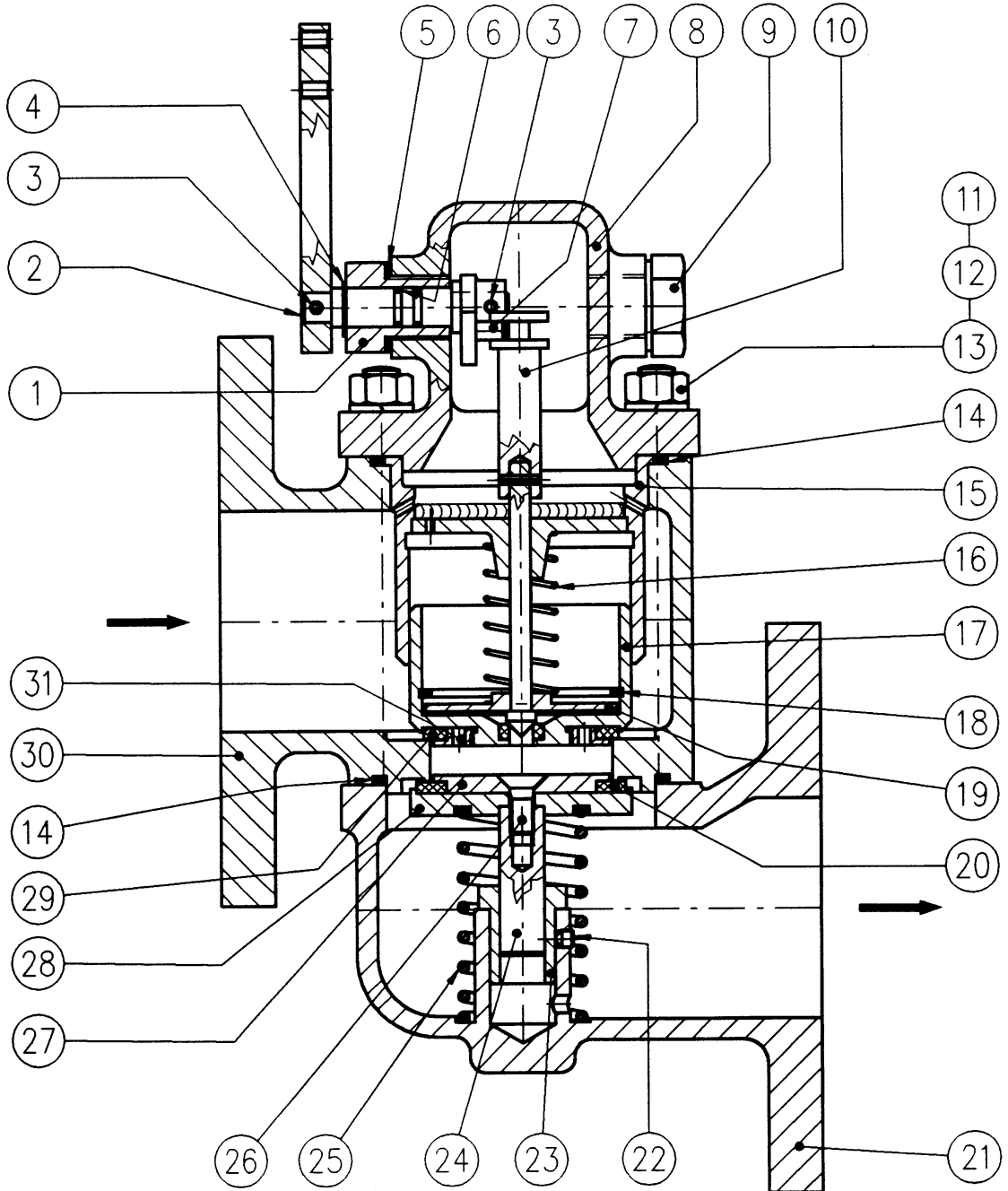

ISOIL IMPIANTI		VALVOLA PRESET CON CHECK ø 3" ANSI 150 ALLUMINIO PRESET VALVE WITH CHECK ø 3" ANSI 150 ALUMINIUM						Dis. 705/3	
								Foglio 1 di 1	
pos. item	N° CODICE N° CODE	DESCRIZIONE DESCRIPTION	Q.tà Q.ty	MATERIALE MATERIAL	pos. item	N° CODICE N° CODE	DESCRIZIONE DESCRIPTION	Q.tà Q.ty	MATERIALE MATERIAL
1	80BO1114	Boccola Bush	1	Ottone Brass	24	80GU2039	Guida valvola Valve guide	1	Acc. inox St. steel
2	80PE1030	Perno Pivot	1	Acc. inox St. steel	25	80MO0006	Molla check Check spring	1	Acc.al carb. Carbon steel
3	80SP5078	Spina spirale Spirol pin	2	Acc.al carb. Carbon steel	26	80VI7063	Vite Screw	1	Acc.al carb. Carbon steel
4	80AN2042	Anello elastico Seeger	1	Acc.al carb. Carbon steel	27	80RO1018	Rondella check Check washer	1	Acc.al carb. Carbon steel
5	80GU0459	Guarnizione O ring	1	Teflon Teflon	28	80PI1063	Piattello check Check plate	1	Acc.al carb. Carbon steel
6*	80GU1210	Guarnizione O ring	2	Viton Viton	29*	80GU0441	Guarnizione pistone Piston gasket	1	Viton Viton
7	80LE0039	Leva interna Internal lever	1	Acc.al carb. Carbon steel	30	80COG174	Corpo Body	1	Alluminio Aluminium
8	80CA0012	Calotta Cap	1	Alluminio Aluminium	31	80GH0036	Ghiera pistone Piston locknut	1	Acc.al carb. Carbon steel
9	80TA1093	Tappo Plug	1	Acc.al carb. Carbon steel					
10	80OT0042	Otturatore pilota Pilot shutter	1	Acc. inox St. steel					
11	80TI0006	Tirante Rod	4	Acc.al carb. Carbon steel					
12	80RO1183	Rondella elastica Elastic washer	4	Acc.al carb. Carbon steel					
13	80DA1072	Dado Nut	4	Acc.al carb. Carbon steel					
14*	80GU1498	Guarnizione Gasket	2	Viton Viton					
15	80GU2036	Guida pistone Piston guide	1	Alluminio Aluminium					
16	80MO0219	Molla pistone Piston spring	1	Acc.al carb. Carbon steel					
17	80PI7024	Pistone Piston	1	Bronzo Bronze					
18	80AN3051	Anello elastico Seeger	1	Acc.al carb. Carbon steel					
19	80PI1054	Piattello di spinta Plate	1	Ottone Brass					
20*	80GU0369	Guarnizione check Check gasket	1	Viton Viton					
21	80GO1003	Gomito check Check elbow	1	Alluminio Aluminium					
22	80GR1006	Grano Dowel	1	Acc. inox St. steel					
23	80BO1162	Boccola Bush	1	Ottone Brass	* Parti di ricambio consigliate / Suggested spare parts				

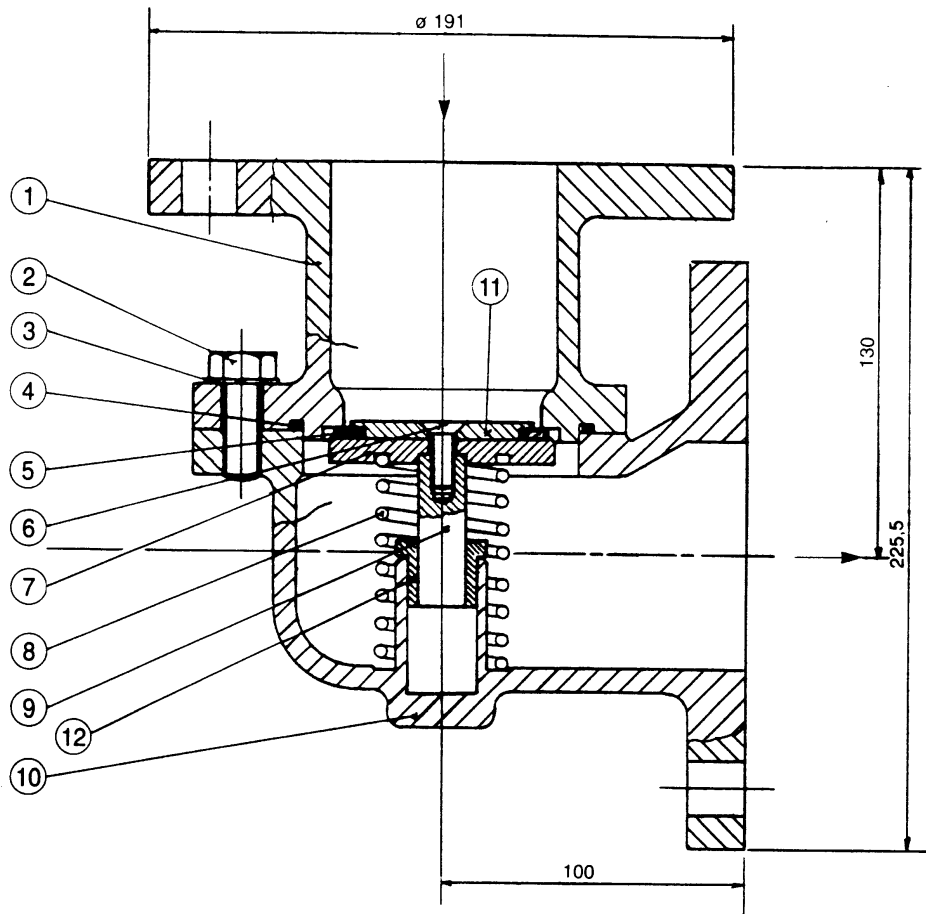

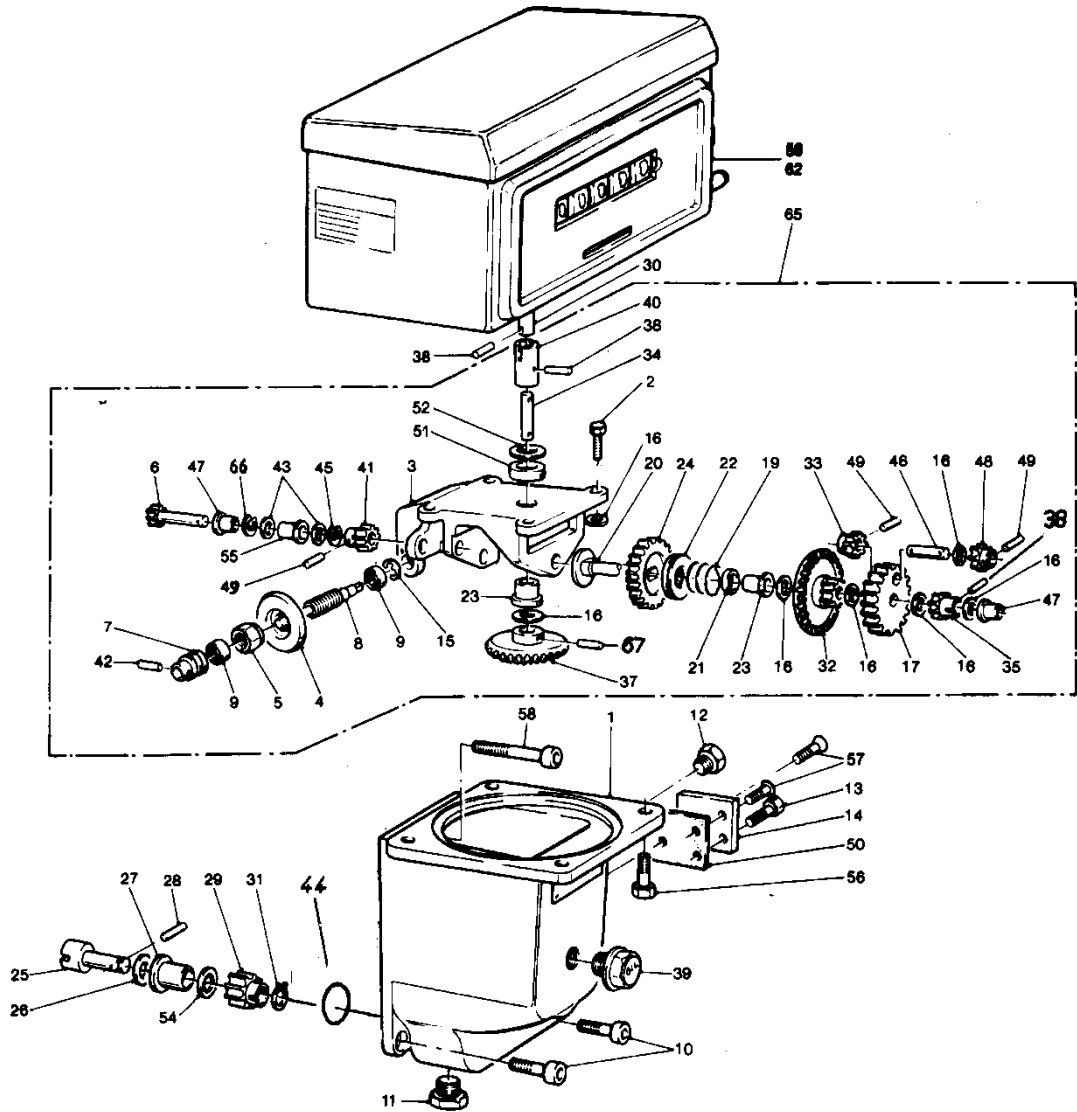

INTRODUZIONE CHIAVI PER
TARATURA CONTATORE
USE OF KEYS FOR
METER'S CALIBRATION

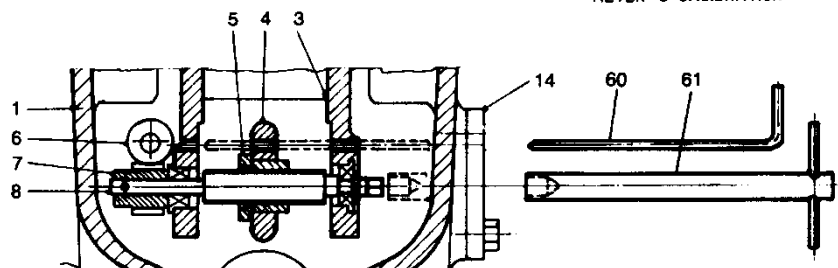

ISOIL IMPIANTI		MECCANISMO DI CALIBRAZIONE CALIBRATION MECHANISM						Dis. 672	
								Foglio 1 di 2	
pos. item	N° CODICE N° CODE	DESCRIZIONE DESCRIPTION	Q.tà Q.ty	MATERIALE MATERIAL	pos. item	N° CODICE N° CODE	DESCRIZIONE DESCRIPTION	Q.tà Q.ty	MATERIALE MATERIAL
1	80SC2000	Scatola Calibr.mechanism box	1	Alluminio Aluminium	25	80AL0282	Albero di trasmissione Drive shaft	1	Aisi 420 Aisi 420
2	80VI2042	Vite fissaggio supporto Support screw	4	Acciaio Carbon steel	26	80RO1066	Rondella di ras. Washer	2	Acciaio Carbon steel
3	80SU0012	Supporto disp.regolaz. Calibr.mech.support	1	Alluminio Aluminium	27	80BO1009	Boccola autolubrif. Bush	1	Bronzo Bronze
4	80AS0027	Ass.disco frizione Friction wheel	1	Acciaio Carbon steel	28*	80SP5009	Spina spirale Spirol pin	1	Acciaio Carbon steel
5		Fornito con pos.4 Supplied with item 4			29	80IN3150	Ingranaggio Z = 20 gear	1	Aisi 420 Aisi 420
6*	80AS0129	Ass.albero con pign. Shaft with pinion	1	Acciaio Carbon steel	30	80AL0270	Alberino prolunga Extension shaft	1	Acciaio Carbon steel
7	80AS0258	Ass. vite senza fine Worm screw	1	Acciaio Carbon Steel	31	80AN2000	Anello elastico x alb. Circlip for shaft	1	Acciaio Carbon steel
8*		Fornito con pos.7 Supplied with item 7			32	80PI5000	Pignone conico Bevel pinion	1	Acciaio Carbon steel
9*	80CU1081	Cuscinetto Bearing	2	Aisi 440 C Aisi 440 C	33		Fornito con pos.17 Supplied with item 17		
10	80VI4201	Vite Screw	2	Acciaio Carbon Steel	34	80AS0084	Ass. alberino/pignone Shaft/gear assy	1	Aisi 420 Aisi 420
11	80TA1072	Tappo scarico Oil discharge plug	1		35	80IN3165	Ingranaggio Gear	1	Acciaio Carbon steel
12	80TA1015	Tappo carico olio Oil charge plug	1		37		Fornito con pos.34 Supplied with item 34		
13	80VI5117	Vite Screw	1	Acciaio Carbon Steel	38	80SP5009	Spina spirale Spirol pin	3	Acciaio Carbon steel
14	80COB069	Coperchio accesso Calibrating cap	1	Alluminio Aluminium	39	81IN0006	Indicatore livello olio Oil level indicator	1	
15	80AN2018	Anello elastico Bearing circlip stop	1	Acciaio Carbon steel	40	80MA1009	Manicotto per trasmis. Transmission sleeve	1	Acciaio Carbon steel
16	80RO1063	Rondella ras. Washer	7	Acciaio Carbon steel	41		Fornito con pos.6 Supplied with item 6		
17	80AS0069	Assieme pignone Pinion assy	1	Acciaio Carbon steel	42	80SP5000	Spina spirale Spirol pin	2	Acciaio Carbon steel
19	80MO0228	Molla spingi disco friz. Friction plate spring	1	Acciaio inox Stainless steel	43	80RO1078	Rondella di ras. Wahser	2	Acciaio Carbon steel
20	80PI1057	Piattello per frizione Friction plate	1	Acciaio Carbon steel	44*	80GU1243	Guarnizione Gasket	1	Viton Viton
21	80RO1042	Rondella di centraggio Washer	1	Acciaio Carbon steel	45	80AN2006	Anello elastico Circlip	1	Acciaio Carbon steel
22*	80CU1045	Cuscinetto reggispira Axial bearing	1	Acciaio Carbon steel	46		Fornito con pos.17 Supplied with item 17		
23	80BO1000	Boccola a flangia Bush	2	Bronzo Bronze	47	80BO1000	Boccola a flangia Bush	2	Bronzo Bronze
24	80IN3135	Ingranaggio Gear	1	Acciaio Carbon steel	* Parti di ricambio consigliate / Suggested spare parts				

SEZ. A-A

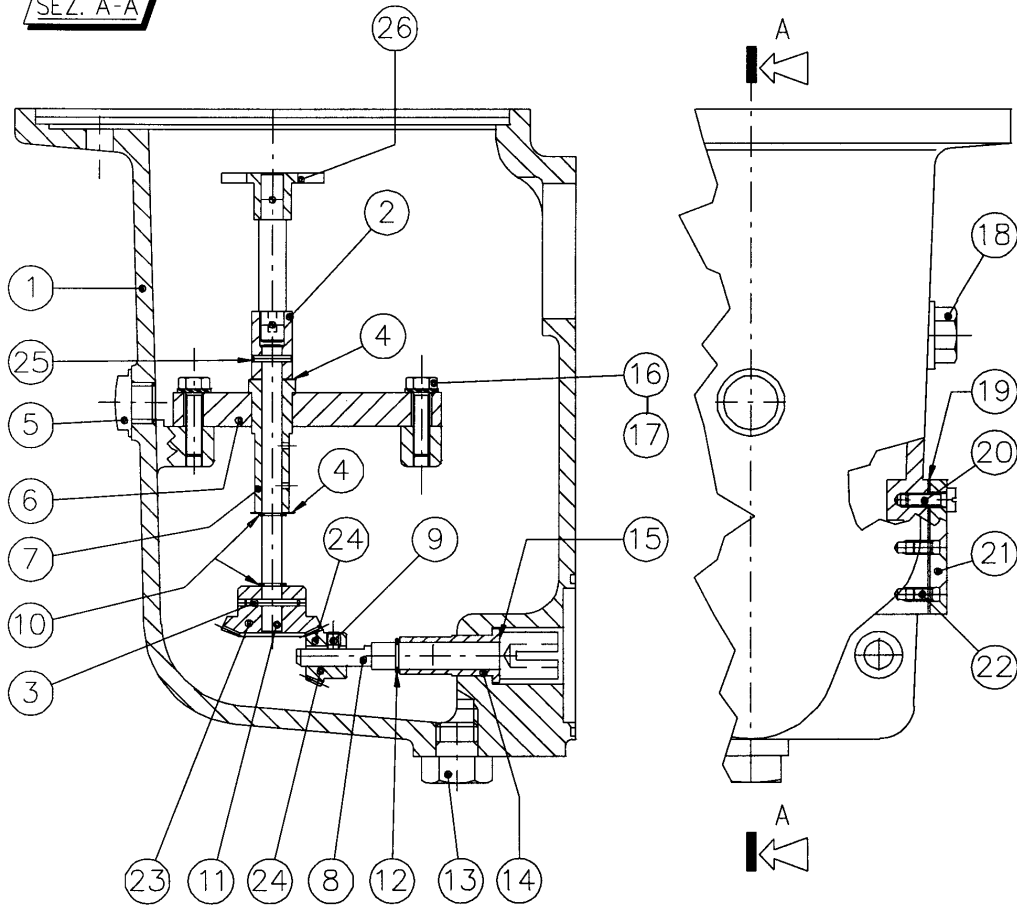

T-3958.DOC

ISO IL 		SCATOLA DI TRASMISSIONE PER MONT.TESTATA VEGA						Dis. 3958	
IMPIANTI		GEARING BOX FOR ELECTR. COUNTER VEGA MOUNTING						Foglio 1 di 1	
pos. item	N° CODICE N° CODE	DESCRIZIONE DESCRIPTION	Q.tà Q.ty	MATERIALE MATERIAL	pos. item	N° CODICE N° CODE	DESCRIZIONE DESCRIPTION	Q.tà Q.ty	MATERIALE MATERIAL
1	80SC2030	Scatola meccanismo Mechanism box	1	Alluminio Aluminium	24	80IN3276	Ingranaggio Gear	1	Acc.carbonio Carbon steel
2	80MA1009	Manicotto di trasmissione Transmission coupling	1	Acc.carbonio Carbon steel	25	80SP5009	Spina spirale Spirol pin	1	Acc.carbonio Carbon steel
3	80SP5018	Spina spirale Spirol pin	1	Acc.carbonio Carbon steel	26	80AS0102	Trascinatore Entrainer	1	Acc.carbonio Carbon steel
4	80RO1078	Rondella di rasamento Washer	4	Acc.carbonio Carbon steel					
5	80IN0006	Indicatore livello olio Oil level indicator	1						
6	80SU0072	Supporto mecc.perVEGA Mech.support for VEGA	1	Alluminio Aluminium					
7	80BO1147	Boccola Bush	1	Bronzo Bronze					
8	80AL0243	Alberino Shaft	1	Acc.inox St.steel					
9	80GR1093	Grano Grain	1	Acc.inox St.steel					
10	80AN2006	Anello elastico Retaining ring	2	Acc. al carb. Carbon steel					
11	80AL0246	Alberino Shaft	1	Acc. inox St. steel					
12	80AN2000	Anello elastico Retaining ring	1	Acc. al carb. Carbon steel					
13	80TA1072	Tappo scarico olio+guarn. Oil discharge plug	1						
14	80BO1099	Boccola Bush	1	Bronzo Bronze					
15	80RO1066	Rondella di rasamento Washer	2	Acc. al carb. Carbon steel					
16	80VI2042	Vite Screw	4	Acc. al carb. Carbon steel					
17	80RO1033	Rondella dent.esterna Exernal washer	4	Acc. al carb. Carbon steel					
18	80TA1015	Tappo carico olio Oil charge plug	1						
19	80GU0207	Guarnizione Gasket	1						
20	80VI5117	Vite Screw	1	Acc. al carb. Carbon steel					
21	80COB069	Coperchio accesso tar. Calibr.inlet cover	1	Alluminio Aluminium					
22	80VI8048	Vite Screw	2	Acc. al carb. Carbon steel					
23	80IN3279	Ingranaggio Gear	1	Acc. al carb. Carbon steel					