

C12 i - C12 i HT ***C18 i - C18 i HT*** **PUMPS**



INSTALLATION

OPERATION

MAINTENANCE

ECCENTRIC PISTON PUMP

MOUVEX PRINCIPLE

SAFETY INSTRUCTIONS, STORAGE, INSTALLATION AND MAINTENANCE

C12 i - C12 i HT - C18 i - C18 i HT MODELS

TECHNICAL CHARACTERISTICS

- Maximum pump speed : **530 rpm**
- Maximum running temperature :
 - **PTFE L seals** 80°C
 - **other seals** :
 - * continuous :.....C12 i - C18 i 100°C
 - C12 i HT- C18 i HT ... 160°C
 - * washing/rinsing/sterilisation :
 - C12 i - C18 i 121°C
- Maximum suction pressure :
 - In normal use, the suction pressure must be higher than the required NPSH and **less than 1,5 barg** (21,75 psig)
 - During **CIP/SIP** of the pump, the suction pressure must not exceed **3 barg** (43,5 psig).
 - Pump **stopped**, the pressure must not exceed **6 barg** (87 psig).
- Acceptable maximal differential pressure :
 - C12 i - C12 i HT9 bar (130,5 psi)*
 - C18 i - C18 i HT6 bar (87 psi)*
- Maximum pressure jacket : **5 barg** (72,50 psig)
- Cylinder capacity :
 - C12 i - C12 i HT0,411 litre
 - C18 i - C18 i HT0,617 litre
- Informations about PTFE L seals (no available with HT version) :
 - This seal is composed of fibreglass.
 - **CAUTION : This seal does not accept thermal shock and Clean In Place.**

* When the pump works with an inlet gauge pressure less than zero, the maximum outlet pressure will be calculated as if the inlet pressure is equal to zero.

SAFETY INFORMATIONS



This is a SAFETY ALERT SYMBOL

When you see this symbol on the product, or in the manual, look for one of the following signal words and be alert to the potential for personal injury, death or major property damage.



Warns of hazards that **WILL** cause serious personal injury, death or major property damage



Warns of hazards that **CAN** cause serious personal injury, death or major property damage.



Warns of hazards that **CAN** cause personal injury or property damage.

NOTICE

Indicates special instructions which are very important and must be followed.

USED PRESSURE UNITS

Unit without suffix :

Differential pressure, for example, pressure difference between equipment suction and discharge.

Unit with suffix "a" :

Absolute pressure.

Unit with suffix "g" :

Gauge pressure, given regarding to atmospheric pressure (~101325 Pa, taken at 1 bar / 14,5 psi in this IOM).

Example :

$P_{suc} = -0,2 \text{ barg} = 0,8 \text{ bara}$

$P_{dis} = 8,8 \text{ barg} = 9,8 \text{ bara}$

$\Delta P = P_{dis} - P_{suc} = 9 \text{ bar}$

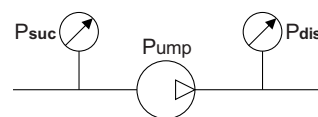
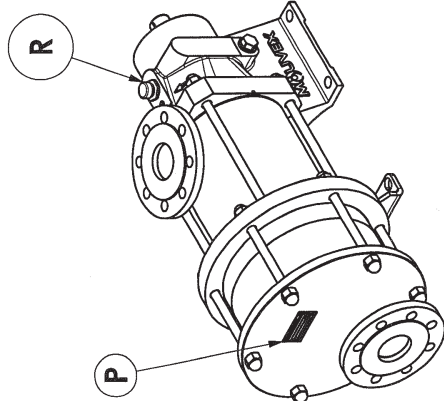
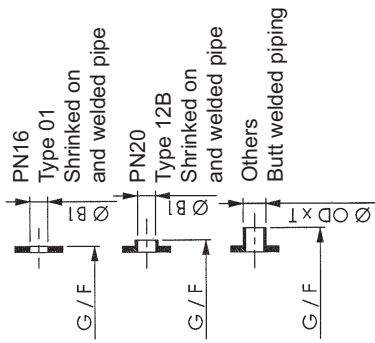
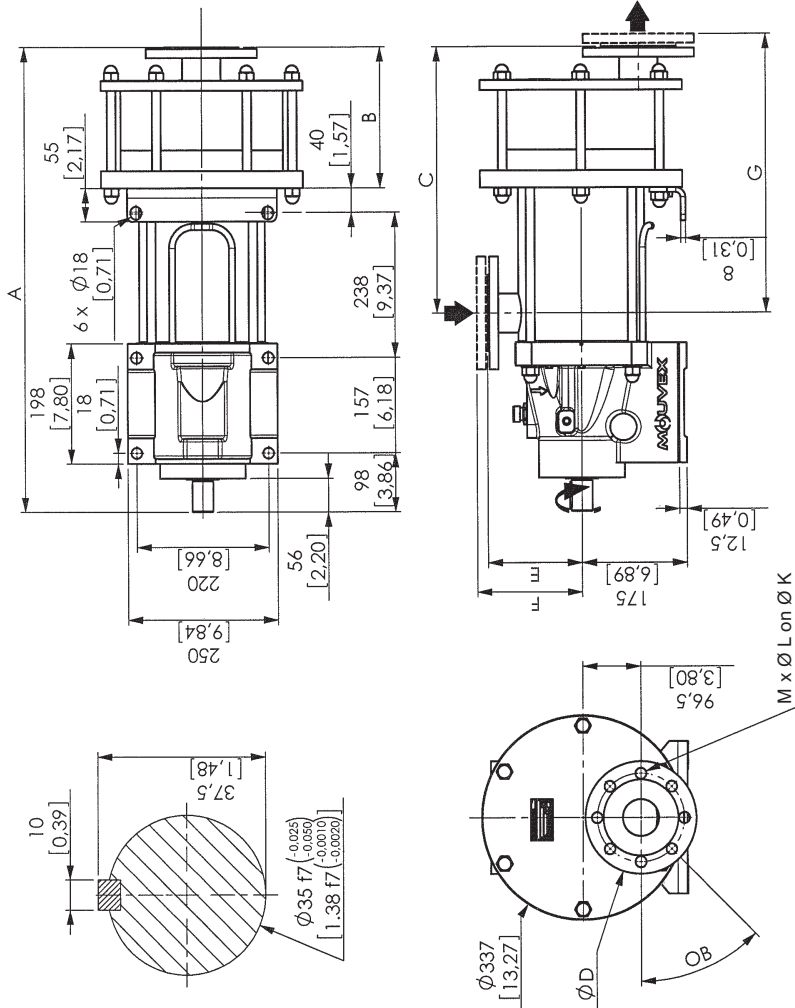

TABLE OF CONTENTS

Page

1. OVERALL DIMENSIONS	5
2. INSTALLATION	11
2.1 Orientation of the pump ports	11
2.2 Direction of rotation	11
2.3 Protection of the pump installation	11
2.4 Hoisting devices	12
2.5 Unit Assembly	12
3. UTILISATION	14
3.1 Noise level	14
3.2 Commissioning	14
3.3 Dry running	14
3.4 Pump stop	15
3.5 Scrapping	15
4. CLEAN IN PLACE (CIP) & STERILISATION IN PLACE (SIP)	15
4.1 General	15
4.2 CIP circuit recommended	15
4.3 Pumps arranged in series	15
4.4 Pumps arranged in parallel	16
4.5 Successive cycles	17
4.6 Sterilisation In Place (SIP)	17
5. MAINTENANCE	17
5.1 Necessary tools	17
6. OPENING OF THE PUMP	18
6.1 Assembly / Dismantling	18
6.2 Checking of parts	19
7. ASSEMBLY OF CYLINDER/PISTON	20
8. PROTECTION OF THE BELLOWS	21
9. CHANGING THE LIP SEAL	22
10. CHANGING THE ORIENTATION OF THE PORTS	23
10.1 Discharge port	23
10.2 Suction port	23
11. DREANING OF BEARING	24
12. OPTIONS	25
12.1 Liquid detector	25
12.2 Bellows monitoring system	25
13. CERTIFICATE OF CONFORMITY	26

C12 i - C18 i with flanges



		Flanges													Weight	
		DN	A	B	C	ØD	E	F	G	ØOD x T	M (no unit)	OB	ØL	ØK	ØB1	kg [lb]
C12i	PN16 (ISO 7005-1)	65	765	232	439	185	155.5	176.5	458	- x -	8	45°	18	145	77.5	116
		Ø 2.569	[30.118]	[9.134]	[17.244]	[7.283]	[6.161]	[6.949]	[18.031]	- x -	8		[0.709]	[5.709]	[3.051]	[256]
C18i	PN20	65	765	252	459	185	155.5	176.5	478	- x -	8	45°	18	145	77.5	122
		Ø 2.569	[30.906]	[9.921]	[18.031]	[7.283]	[6.161]	[6.949]	[18.819]	- x -	8		[0.709]	[5.709]	[3.051]	[269]
C12i	PN20 (ISO 7005-1)	65	765	232	439	180	155.5	185.5	467	- x -	4	45°	18	130.5	74.5	116
		Ø 2.569	[30.118]	[9.134]	[17.244]	[7.087]	[6.161]	[7.303]	[18.386]	- x -	4		[0.709]	[5.482]	[2.933]	[266]
C18i	Connect-S® *	65	765	252	459	180	155.5	185.5	487	- x -	4	45°	18	130.5	74.5	122
		Ø 2.569	[30.906]	[9.921]	[18.031]	[7.087]	[6.161]	[7.303]	[19.173]	- x -	4		[0.709]	[5.482]	[2.933]	[269]
C12i	Connect-S® *	65	772	240	446	145	164.5	228.5	510	70 x 2.00	8	22.5°	13	115	-	114
		Ø 2.569	[30.433]	[9.449]	[17.559]	[5.709]	[6.476]	[8.998]	[20.079]	[2.756 x 0.079]	8		[0.512]	[4.528]	-	[252]
C18i	Connect-S® *	65	792	260	466	145	164.5	228.5	530	70 x 2.00	8	22.5°	13	115	-	120
		Ø 2.569	[31.221]	[10.236]	[18.346]	[5.709]	[6.476]	[8.998]	[20.866]	[2.756 x 0.079]	8		[0.512]	[4.528]	-	[265]
C12i	DIN 11864 BF-A-DN60	65	765	232	439	113	165.5	182	464	70 x 2.00	8	22.5°	9	95	-	116
		Ø 2.569	[30.118]	[9.134]	[17.244]	[4.449]	[6.161]	[7.165]	[18.268]	[2.756 x 0.079]	8		[0.354]	[3.74]	-	[256]
C18i	DIN 11864 BF-A-DN60	65	765	252	459	113	165.5	182	484	70 x 2.00	8	22.5°	9	95	-	122
		Ø 2.569	[30.906]	[9.921]	[18.031]	[4.449]	[6.161]	[7.165]	[19.055]	[2.756 x 0.079]	8		[0.354]	[3.74]	-	[269]

P	Pump plate
R	Filling/Breather
V	Draining

*Connect S® is a registered trademark owned by NEUMO.

C12 i HT - C18 i HT with flanges

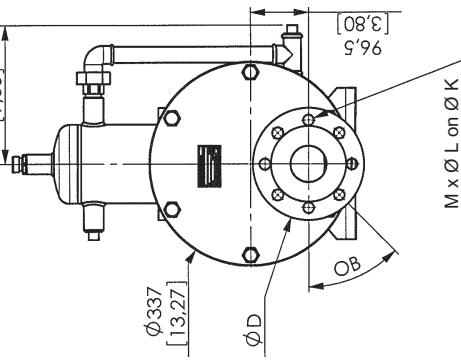
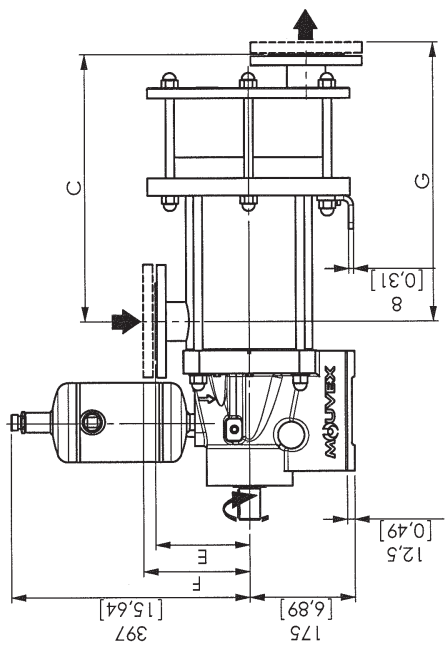
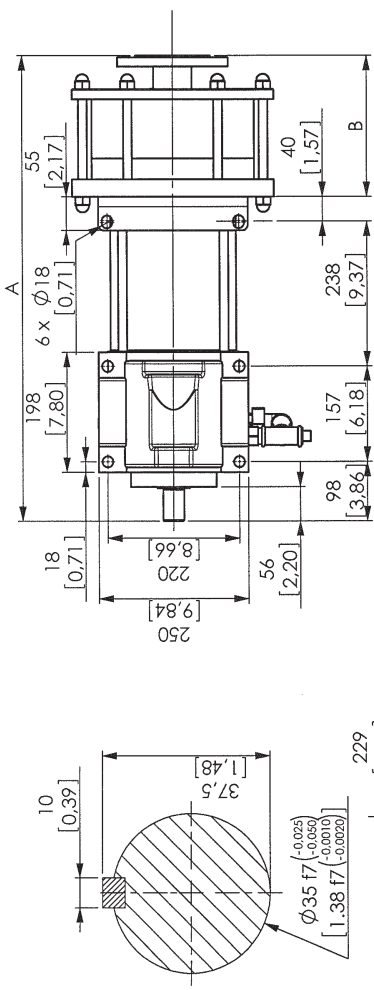
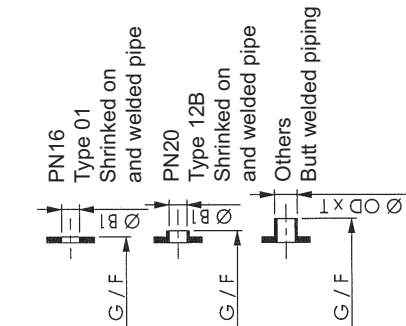
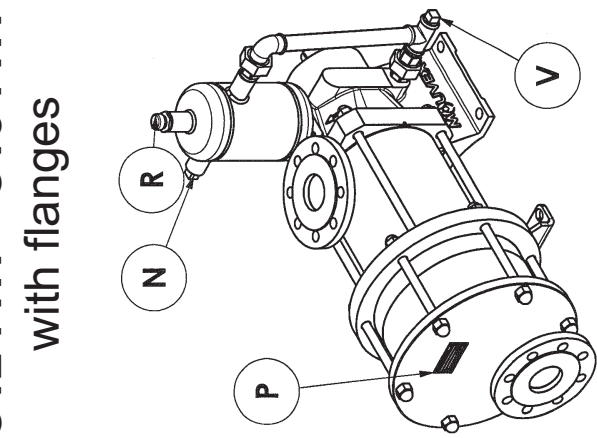

Flanges												
DN	A	B	C	ØD	E	F	G	ØOD x T	M (no unit.)	OB	ØK	Weight kg [lb]
C12 i HT PN16 (ISO 7005-1)	765 [30.118]	232 [9.134]	438 [17.244]	185 [7.283]	156.5 [6.161]	176.5 [6.948]	458 [18.031]	- x -	8	45°	18 [0.709]	119 [4.528]
C18 i HT	785 [30.906]	262 [10.315]	458 [18.031]	185 [7.283]	156.5 [6.161]	176.5 [6.948]	478 [18.819]	- x -	8	45°	18 [0.709]	126 [4.528]
C12 i HT PN20 (ISO 7005-1)	765 [30.118]	232 [9.134]	438 [17.244]	160 [6.300]	156.5 [6.161]	185.5 [7.303]	467 [18.386]	- x -	4	45°	18 [0.709]	119 [4.528]
C18 i HT	785 [30.906]	262 [10.315]	458 [18.031]	160 [6.300]	156.5 [6.161]	185.5 [7.303]	487 [19.173]	- x -	4	45°	18 [0.709]	126 [4.528]
C12 i HT Connect-S®	773 [30.433]	240 [9.449]	446 [17.559]	145 [5.709]	164.5 [6.476]	228.5 [9.000]	510 [20.079]	70 x 2.00 [2.756 x 0.079]	8	22.5°	13 [0.512]	119 [4.528]
C18 i HT	793 [31.221]	260 [10.236]	466 [18.346]	145 [5.709]	164.5 [6.476]	228.5 [9.000]	530 [20.866]	70 x 2.00 [2.756 x 0.079]	8	22.5°	13 [0.512]	125 [4.528]

P	Pump plate
R	Filling / Breather
V	Draining
N	Oil level

*Connect S[®] is a registered trademark owned by NEUMO.

1. OVERALL DIMENSIONS

C12 i - C18 i with connections

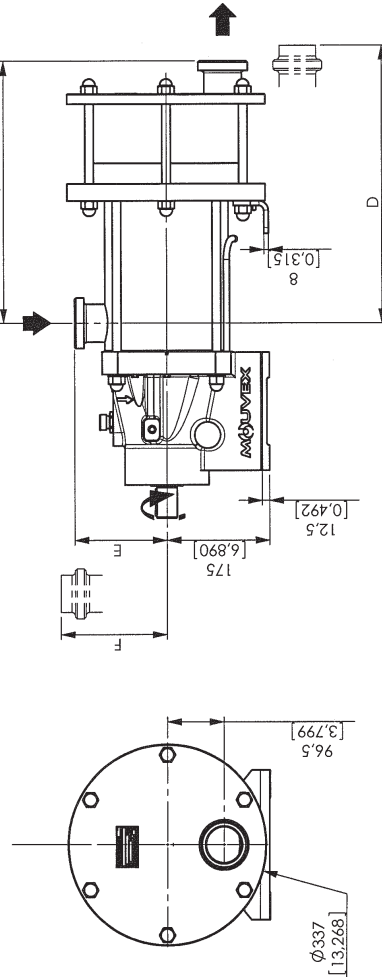
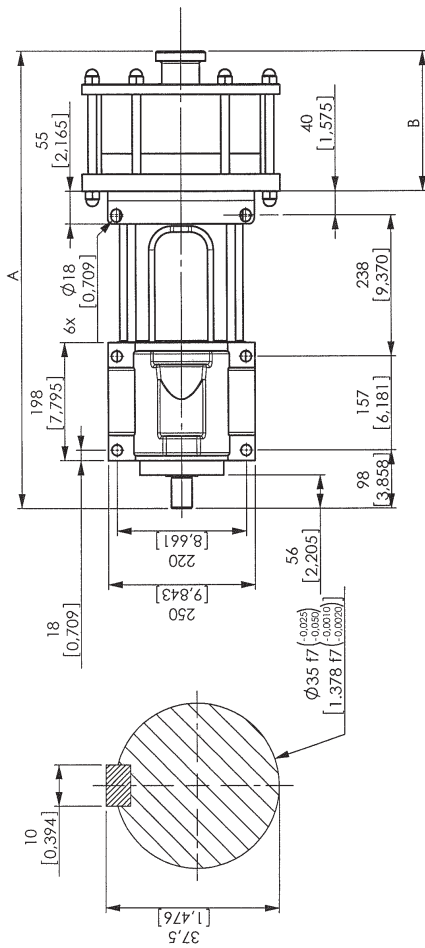
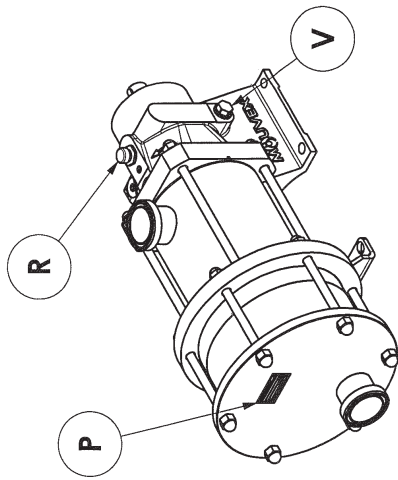

P	Pump plate
R	Filling/Breather
V	Draining

		Connections										Weight
		DN	A	B	C	D	E	F	OD x T	Weight		
		kg [lb]										
SMS 1145	C12i	63.5	765	232	438	460.5	156.5	179	63.5 x 1.5	115		
	C18i	63.5	785	252	458	480.5	156.5	179	2.5 x 0.069	[254]		
Clamp (ISO 2852)	C12i	63.5	765	232	438	460.5	156.5	179	64.1 x 1.9	115		
	C18i	63.5	785	252	458	480.5	156.5	179	2.524 x 0.075	[265]		
RJT (BS 4825-5)	C12i	63.5	765	232	438	448	156.5	166.5	63.75 x 1.725	115		
	C18i	63.5	785	252	458	468	156.5	166.5	2.51 x 0.068	[254]		
FIL-IDF (ISO 2853)	C12i	63.5	765	232	438	460.5	156.5	179	64.10 x 1.9	115		
	C18i	63.5	785	252	458	480.5	156.5	179	2.524 x 0.075	[265]		
Cherry Burrel	C12i	63.5	765	232	438	480.5	156.5	179	63.5 x 1.65	115		
	C18i	63.5	785	252	458	480.5	156.5	179	2.5 x 0.065	[254]		
DIN 11851	C12i	65	765	232	438	460.5	156.5	179	72 x 3	115		
	C18i	65	785	252	458	480.5	156.5	179	2.835 x 0.118	[254]		
Smooth pipe*	C12i	63	755	222	428	-	126.5	-	64 x 2	115		
	C18i	63	775	242	448	-	146.5	-	64 x 2	120		

*CAUTION : When welding the connections, the below should be protected.

1. OVERALL DIMENSIONS (continued)

C12 iHT - C18 iHT with connections

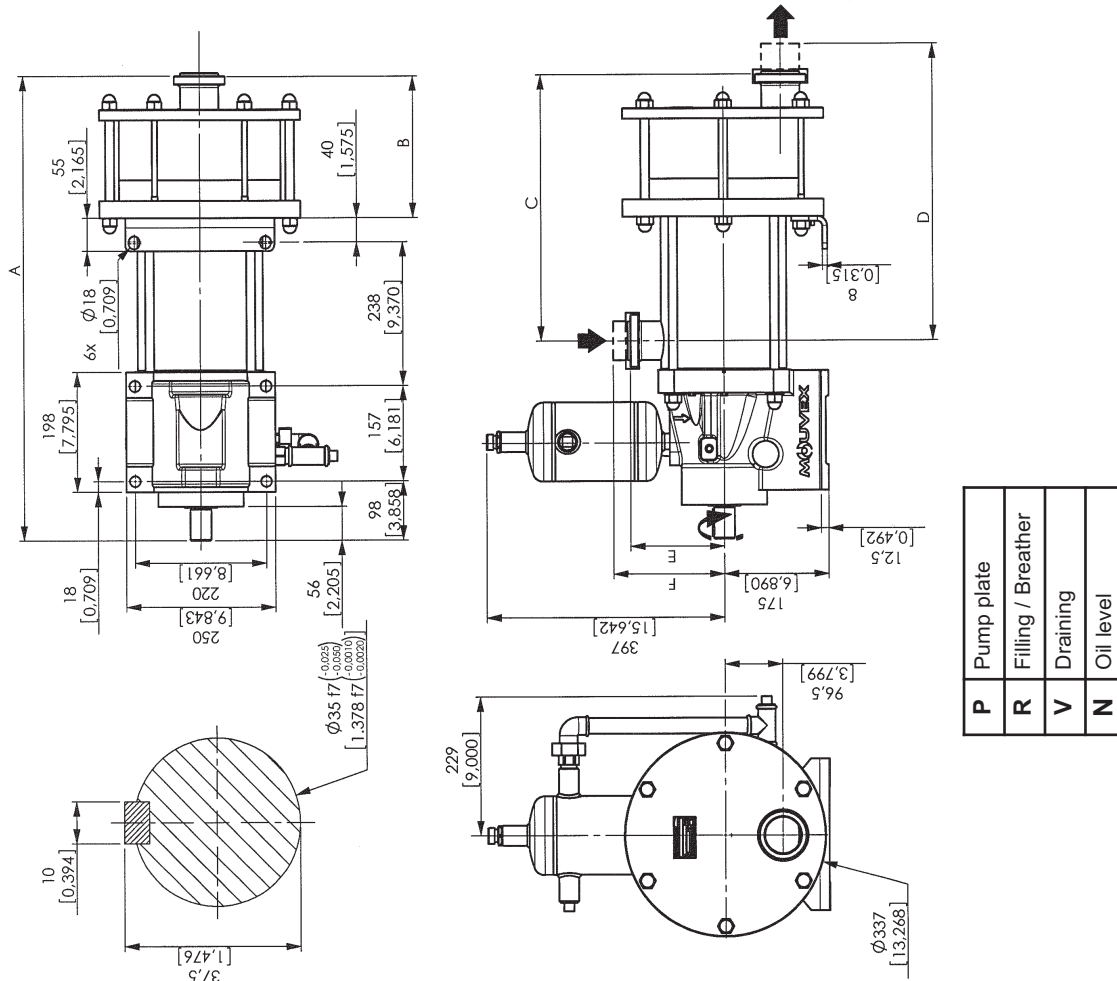

		Connections						Weight	
	DN	A	B	C	D	E	F	OD x T	kg [lb]
RJT (BS 4825-5)	C12i HT	765	232	438	448	156.5	166.5	63.75 x 1.725	118
	C18i HT	785	252	458	468	156.5	166.5	63.75 x 1.725	123
DIN 11851	C12i HT	765	232	438	460.5	156.5	179	72 x 3	118
	C18i HT	785	252	458	480.5	156.5	179	72 x 3	123
Smooth pipe*	C12i HT	765	222	428	-	146.5	-	64 x 2	118
	C18i HT	775	242	448	-	146.5	-	64 x 2	123

*CAUTION : When welding the connections, the below should be protected.

1. OVERALL DIMENSIONS (continued)

C12 i - C18 i with heating jacket

Not contractual drawing

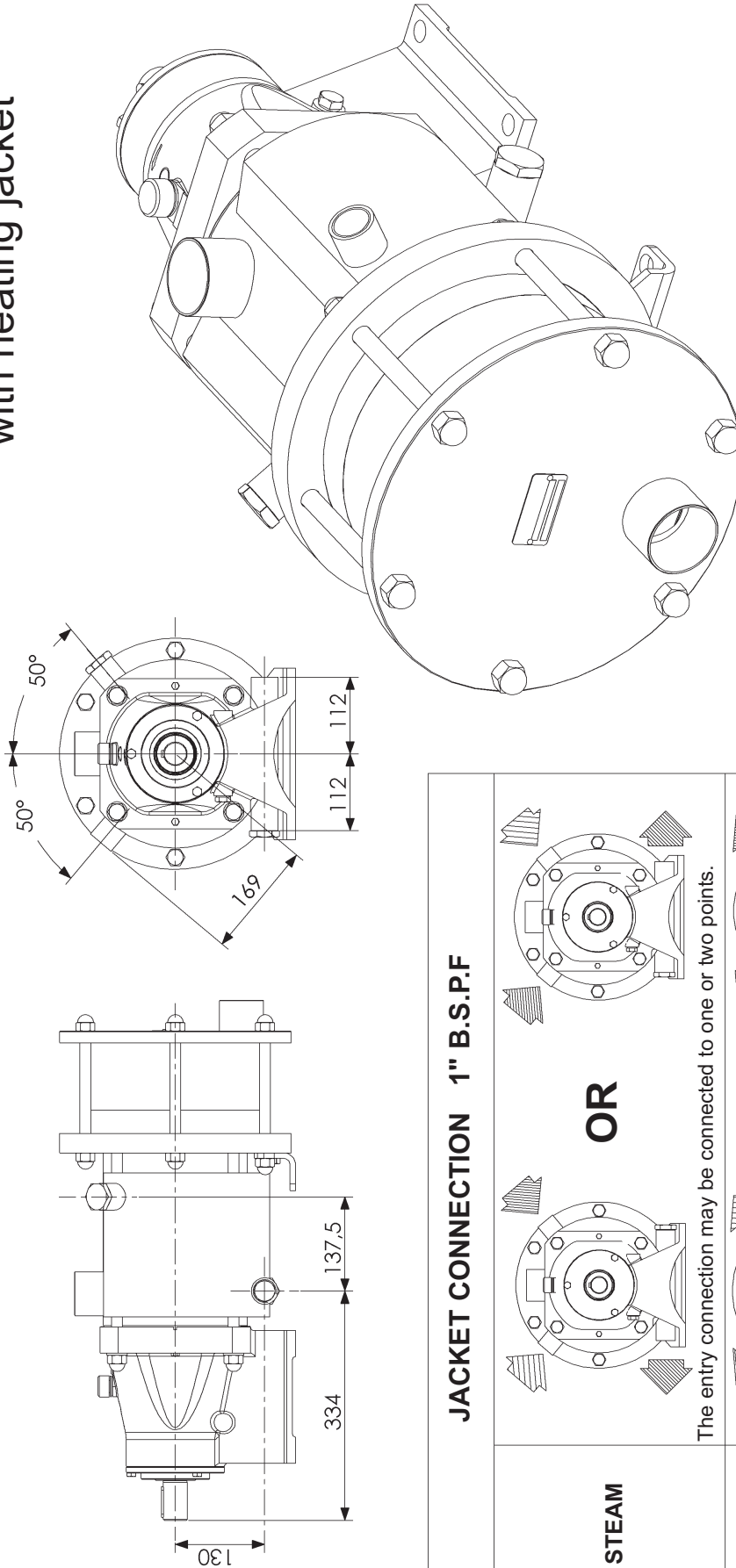

NOTE :

For the other sides, see the specific overall dimension plan for the connection.

Maximum jacket temperature : FKM and FEP encapsulated FKM seals : 180°C

CAUTION :

The pumped product must not exceed the temperature of 100°C.

On jacketed pumps, suction port can only be in position 2 (top). Positions 1 and 3 (sides) are not possible.

FOR ATEX PUMPS, SEE INSTRUCTIONS NR 1050.

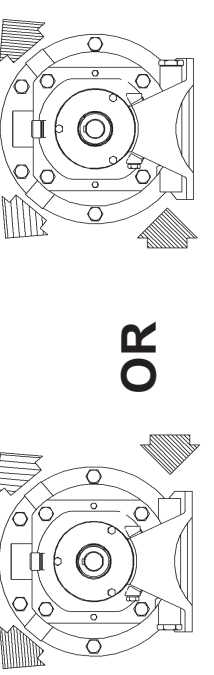
STEAM	 <p style="text-align: center;">OR</p> <p>The entry connection may be connected to one or two points.</p>
LIQUID	 <p style="text-align: center;">OR</p> <p>The outlet connection may be connected to one or two points. If it is done at 1 point, purge the air at the second point.</p>

Bellows monitoring system C12 i - C18 i

1. OVERALL DIMENSIONS (continued)

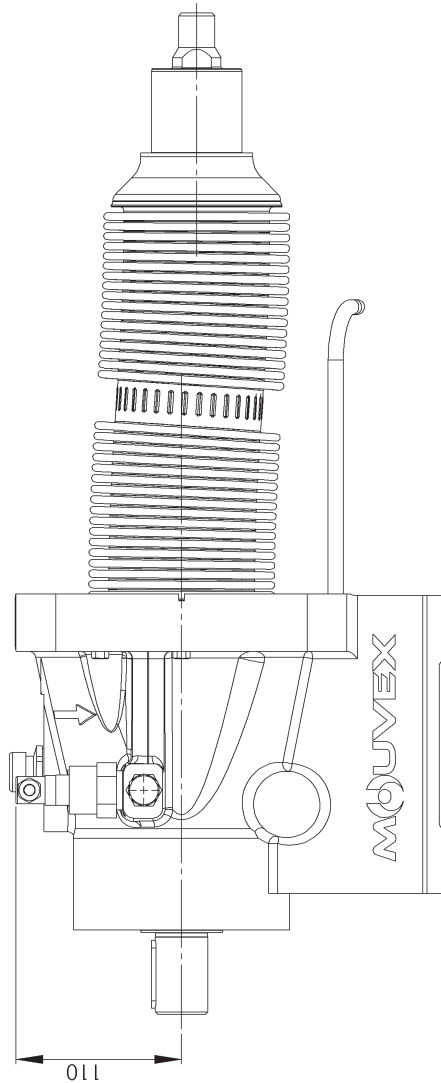
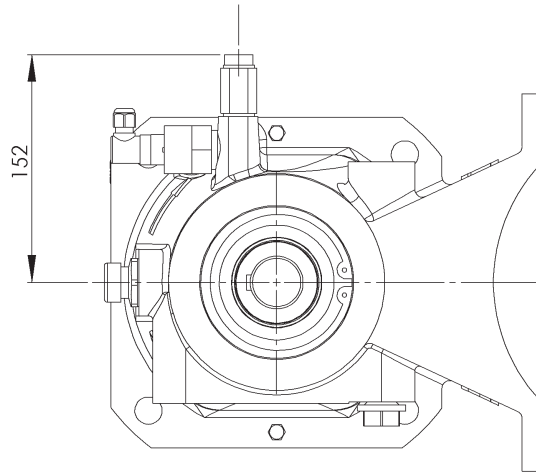

CAUTION :
A BAD CONNECTION CAN
DESTROY THE SENSOR.

Wiring diagram
Connector
Do not use S2

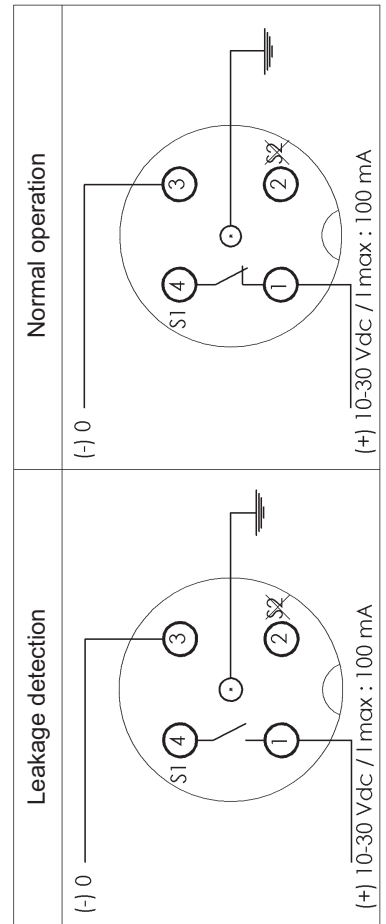

NOTA :
Setting of detection levels is done in factory and do not have to be modified.
For other dimensions, report to pump dimensional drawing.
The dismantling of the transmission could be done only in factory.

1. OVERALL DIMENSIONS (continued)

Bellows monitoring system ATEX C12 i - C18 i

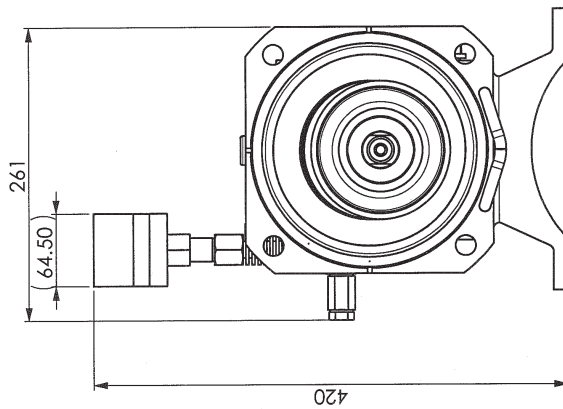
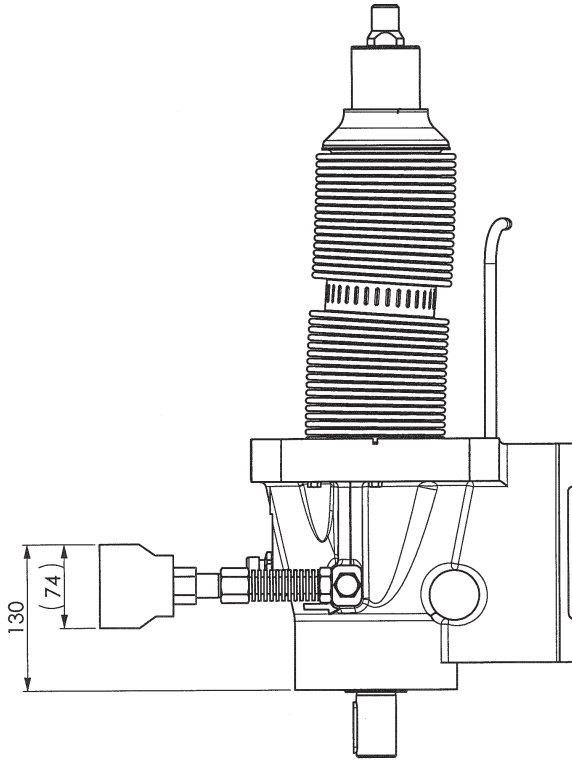

NOTA :
Setting of detection levels is done in factory and do not have to be modified.
For other dimensions, report to pump dimensional drawing.
The dismantling of the transmission could be done only in factory.

Connection diagram

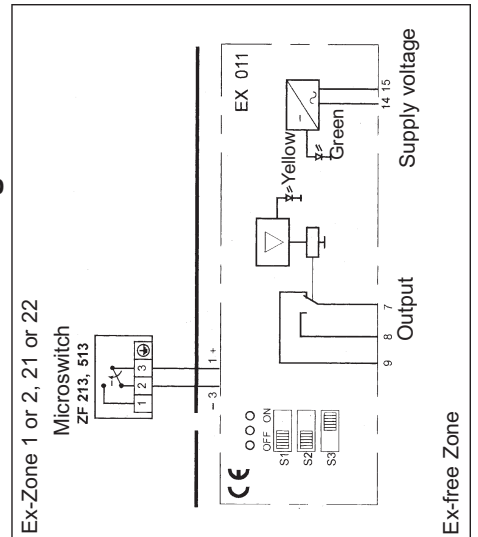

With falling pressure 3-2 opens.

CAUTION :
Incorrect connection can lead to :
- a flammability risk,
- ineffective monitoring,
- possible damage to the sensor.

Double ply transmission with manometer

C12 i - C18 i

1. OVERALL DIMENSIONS (continued)

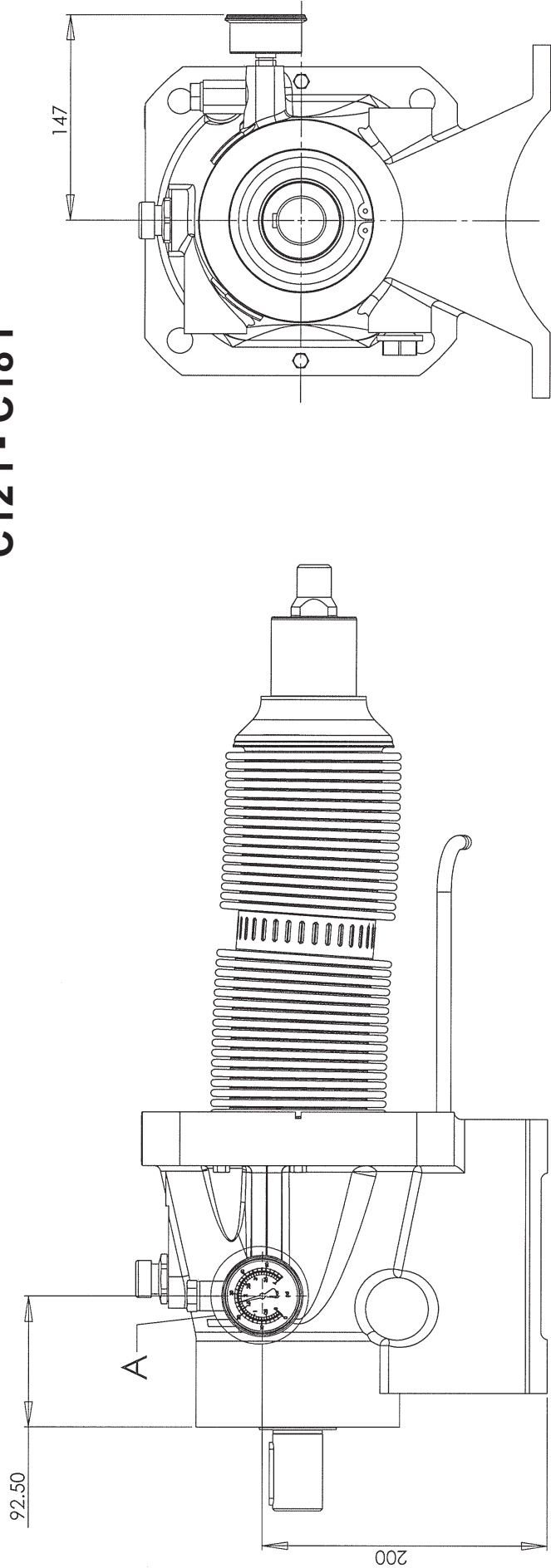

NOTA :
 Setting of detection levels is done in factory and do not have to be modified.
 For other dimensions, report to pump dimensional drawing.
 The dismantling of the transmission could be done only in factory.

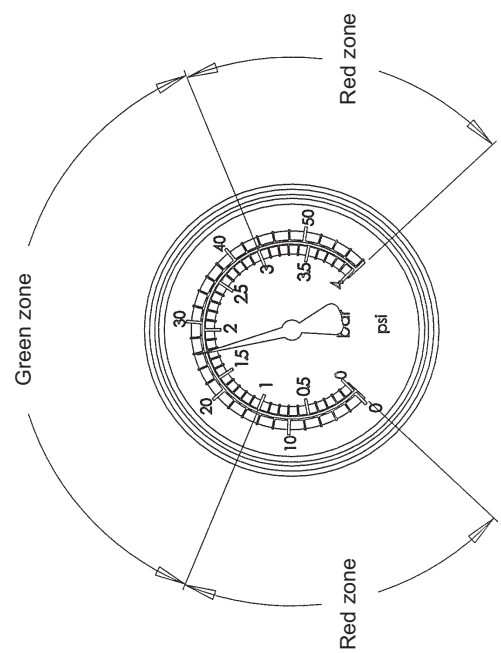

2. INSTALLATION

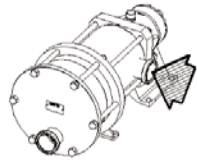
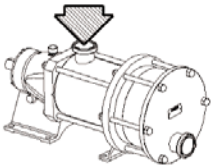
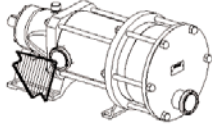
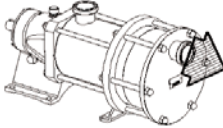
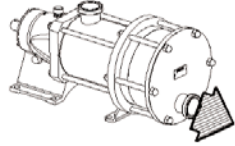
POSSIBLE POSITIONS				
SUCTION	1	2 STANDARD	3	
				
DISCHARGE		2		4 STANDARD
				

The C Series pump is a selfpriming volumetric PD pump.

Therefore, the pump must not run on a circuit with a closed valve. This is valid both for the suction circuit and for the discharge circuit.

2.1 Orientation of the pump ports

The suction and discharge ports may be oriented in various positions.

If the ports positions needs to be changed at any time, see the corresponding paragraph.

NOTICE

C-Series pumps remains drainable whatever position is chosen for the inlet port, but the outlet port must be at the bottom (position 4) to keep the self-draining capability.

2.2 Direction of rotation

When looking at the shaft, the rotation will be clockwise. When looking at the front cover, the direction of rotation will be anti-clockwise. An arrow situated on the bearing housing indicates the correct direction of rotation.



Verification of the correct rotation direction :
Turn the pump the wrong way is not dangerous for the pump.

2.3 Protection of the pump installation

- For ease of maintenance, it is a good idea to place isolation valves before and after the pump. The sizing of these valves must correspond to the diameter of the pipes.
- Before any start-up, during operation or complete stopping of the pump, make sure the valves are open.
- During stop periods, with the pump full of product, either the suction or discharge circuit must be left open to enable expansion or contraction of the pumped product through reheating or cooling. If this instruction is not complied with, The bellows may be damaged and lead to premate failure.
- The bearing must be ventilate at all times, therefore the breather mounted on the bearing must be re-used. Never put the bung on.
- In case of flodded suction, it is possible to install a liquid detector in the place of the transmission breather (see § options). This detector will enable the user to be informed in the case of failure of the bellows. In the case of detection, the installer must make sure the pump is stopped and the isolating valves are closed. Non compliance with this instruction can lead to the pumped product being spilt outside the pump.
- It is possible to have a puncture detection system with double-walled bellows : an inert gas is maintained under pressure between the 2 walls and said pressure is permanently monitored. A signal is dispatched immediately should a wall become punctured (see § OPTIONS).
- The stop time may lead to cooling of the product in the pump and therefore to an increase in viscosity. If this is the case, we recommend re-starting the pump at a speed adapted to this new viscosity (starting pump). Once the product arrives in the pump at the installation definition temperature, the pump may run at the speed specified for this application.

2. INSTALLATION (continued)

- Protection against excess pressure :

The pump must be protected against excess pressure. It can be delivered with a pressure switch to carry out this function.

If protection is provided by a control valve, check that the system does not generate excess pressure at the bellows (particularly if there are water hammers). Operating in this way would damage the bellows and shorten their lifetime.

⚠ CAUTION

Hazardous pressure can cause personal injury or property damage.

INCORRECT SETTINGS OF THE PRESSURE RELIEF VALVE CAN CAUSE PUMP COMPONENT FAILURE, PERSONAL INJURY, AND PROPERTY DAMAGE.

⚠ CAUTION

Hazardous pressure can cause personal injury or property damage.

FAILURE TO INSTALL ADEQUATELY SIZED PRESSURE RELIEF VALVE(S) CAN CAUSE PROPERTY DAMAGE, PERSONAL INJURY OR DEATH.

⚠ CAUTION

Hazardous pressure can cause personal injury or property damage.

PUMPS OPERATING AGAINST A CLOSED VALVE CAN CAUSE SYSTEM FAILURE, PERSONAL INJURY AND PROPERTY DAMAGE.

- Protection against foreign bodies :

The pump and the installation must also be protected against any risk of damage through the passage of foreign bodies by mounting a pre-filter at the pump suction.

In the case of foreseeable clogging of the pre-filter, we recommend using a vacuum switch to inform the user of pre-filter clogging. Prolonged running under cavitation may damage the pump.

2.4 Hoisting devices

Hoisting points :

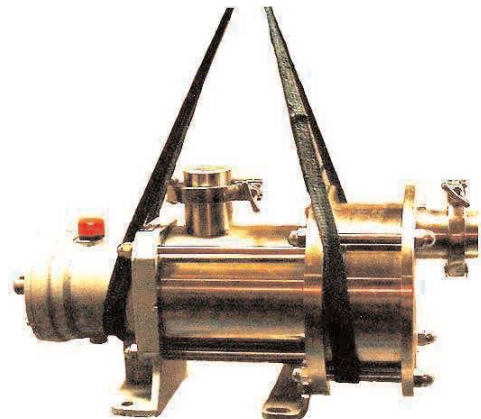

2.5 Unit Assembly

The following instructions apply to pumps delivered with a bare shaft or for MOUVEX motor-driven pump units (if the latter have no specific instruction notice).

2.5.1 INSTALLATION OF UNITS

⚠ WARNING

The weight of the parts can be dangerous and may provoke bodily injuries or material damages.

BE CAREFUL WITH THE WEIGHT OF THE PARTS WHEN THEY ARE BEING REMOVED.

⚠ WARNING

Dangerous voltage. Can cause injury and death.

DISCONNECT THE ELECTRICITY SUPPLY BEFORE ANY MAINTENANCE OPERATION.

The base below the unit is fundamental to ensuring correct operation and long service life.

The unit's base must be flat, level and sufficiently resistant to absorb the stresses caused by the motor-driven pump unit without deformation (if it is made of concrete, it must comply with the BAEL 91 standard).

If the unit is fastened using securing lugs or bolts, it must be carefully wedged to avoid deforming the frame while the bolts are tightened. A deformed frame would apply damaging stresses on the pump and the drive mechanism and misalign the coupling, causing vibrations, noise and premature wear. Ensure that the frame is well above the floor, except from the support plates.

2. INSTALLATION (continued)

If the unit is to be used in a food environment, support plates that allow the unit to be lifted for easier cleaning are recommended.

Allow, if possible, a clear space of approximately 50 cm on each side of the motor-driven pump unit (overall dimensions) to facilitate cleaning and give access if necessary to the pump, reduction gear and motor fastening nuts. In all cases, the dimensions around the motor-driven pump unit must be designed to give the space required for dismantling the pump (if the need arises, use the values given on the overall dimension drawing).

For staff and equipment protection, the frame includes a ground connection point that should be used.

2.5.2 ALIGNMENT OF THE MOTOR/PUMP OR REDUCTION GEAR/PUMP SHAFTS

⚠ WARNING

Do not operate without guard in place.

IF OPERATED WITHOUT THE SHAFT GUARD, THERE IS CONSIDERABLE RISK OF SEVERE PERSONAL INJURY, SIGNIFICANT PROPERTY DAMAGE OR EVEN DEATH.

⚠ WARNING

Dangerous voltage. Can cause injury and death.

DISCONNECT THE ELECTRICITY SUPPLY BEFORE ANY MAINTENANCE OPERATION.

NEVER START A UNIT IF THE COUPLING ALIGNMENT IS INCORRECT. THIS IS A CONDITION OF OUR GUARANTEE.

REMINDER :

Coupling must never be used to compensate for a misalignment.

To control the alignment between the coupling and the shaft, use a straight-edge for concentricity and thickness gauges for angular misalignment (see instructions of the coupling for authorised values).

The 3 figures below show in detail the operation and the possible defects :

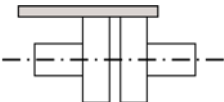
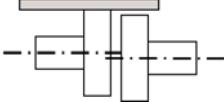
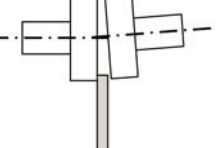
<i>Make this check for 4 points: up - down - left - right</i>	
	<i>Correct</i>
	<i>Out-of-parallelism</i>
	<i>Angular defect</i>

Controlling the alignment at each stage of the installation is important to be sure that none of these stages have generated stresses on the unit or the pump :

- after fastening on the foundations.
- after fastening the pipes.
- after the pump has been operated at the normal operating temperature.

Where the pumps are supplied assembled as a unit, the motor and pump shafts have been perfectly aligned in the factory before delivery, but they must be systematically controlled on acceptance at the site and realigned if necessary.

To do this, do not modify the wedging of the various parts, but check the flatness of the support surface and use the adjustable foot to clear the frame of stresses that could affect it.

2.5.3 ELECTIC MOTORS

⚠ WARNING

Dangerous voltage. Can cause injury and death.

DISCONNECT THE ELECTRICITY SUPPLY BEFORE ANY MAINTENANCE OPERATION.

Check the compatibility of the instructions on the motor with the supply voltage.

Follow the wiring diagram, use wiring that is appropriate for the power and be particularly careful about the contacts which must be well tightened.

The motors should be protected with circuit breakers and suitable fuses. Connect the regulatory electrical grounding.

2. INSTALLATION (continued)

2.5.4 THERMIC MOTORS



THE SURFACES CAN BE AT A TEMPERATURE LIABLE TO CAUSE INJURY OR SEVERE DAMAGE.

Do not forget that these motors are not reversible. It is absolutely necessary to carefully control the suction and discharge sides of the pump before connecting the group to the piping.

Using electric motors is very common now; however, we strongly advise careful reading of the accompanying instruction manual.

2.5.5 CONTROL OF THE SENSE OF ROTATION



TAKE ALL NECESSARY MEASURES TO RENDER ANY START-UP, EVEN ACCIDENTAL, OF THE PUMP DURING THE WORK IMPOSSIBLE.

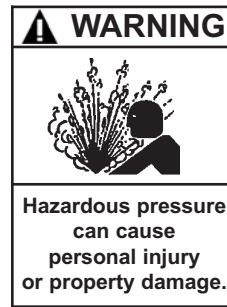

IT IS IMPERATIVE THAT THE HYDRAULIC PRESSURE IS RELEASED BEFORE EACH MAINTENANCE OPERATION TO AVOID PERSONAL INJURY OR MATERIAL DAMAGE.

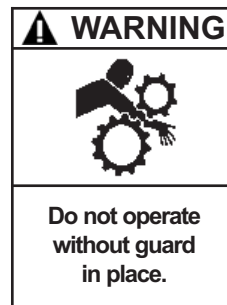

A DRIVE SHAFT GUARD BETWEEN THE PTO AND PUMP MUST BE PROVIDED TO PREVENT PERSONAL INJURY, PROPERTY DAMAGE, OR DEATH.

This control needs to be done with no liquid pumped through the pump, and both the suction and discharge circuits venting to avoid generating unexpected pressure (at the suction side, for example). This will ensure that the control will not damage either the pump or the installation.

Start the pump empty to check that the connections are good and that the direction of rotation corresponds to the suction and discharge direction on the installation. If it is necessary to reverse the direction of rotation, follow the instructions below :

Three-phase motor : switch any 2 current input wires.

Bi-phase motor : switch two same phase wires.

Single-phase motor : follow the instructions on the notice supplied with the motor.

3. UTILISATION

3.1 Noise level

The sound level of a pump is greatly influenced by its conditions of use. Cavitation and pumping products with high gas contents generally increases the sound level.

Under the following pumping conditions :

- excluding cavitation
- discharge pressure :
 - C12 : 9 bar (130,5 psi)
 - C18 : 6 bar (87 psi)
- speed of rotation 450 rpm
- product viscosity of 1 cSt

The sound level reached for the C12 / C18 pump in good conditions without the drive is less than 81 dB(A).

3.2 Commissioning

Make sure that the circuit valves are open before starting the pump.

To avoid any risk of polluting the product to be pumped, rinse the whole installation before starting-up so as to eliminate any contaminants that may remain in the piping, tanks etc. at the time of installation.

For any pure water pumping during process or cleaning operations, consult Mouvex imperatively.

3.3 Dry running

The C series pump is self priming and is capable of emptying the pipes. To do this, it can run dry for a maximum duration of 5 minutes.

3. UTILISATION (continued)

3.4 Pump stop

So as not to damage the pump, make sure that the pump is completely stopped before closing the valves.

3.5 Scrapping

The pump must be scrapped in compliance with the regulations in force.

During this operation, particular care must be paid to the drainage stages of the pump (pumped product) and of its transmission (lubricant).

4. CLEAN IN PLACE (CIP) & STERILISATION IN PLACE (SIP)

4.1 General

On-site cleaning (CIP) of an installation is undertaken by circulating various cleaning solutions through the equipment parts.

An automated CIP system enables :

- Preparation of the appropriate concentrations for the different cleaning solutions.
- Re-heating of certain cleaning solutions at the optimum temperature.
- Circulation of the different solutions through the equipment parts to be cleaned.
- Rinsing and drying of the equipment parts.

For the most part, automated CIP systems are an integral part of process equipments.

Before starting CIP and if the process has not been followed by a water flush, care must be taken that a minimum of residual products remains in the piping and in the pump. The C Series pumps, thanks to their excellent suction and compression capabilities, enable reducing the quantities of residual products. This minimises loss of products, eases cleaning and reduces cycle times.

The C Series pumps are perfectly adapted to all processes necessitating CIP. C-Series pumps are 3-A marked units and have been successfully tested for in-place cleanability according to EHEDG document n°2. By complying with the installation rules described above, these pumps will give you entire satisfaction for a long time.

The start of CIP must immediately follow the end of the process to avoid any clogging or untimely drying.



AT NO TIME MAY THE C SERIES OFFSET PLUNGER PUMPS BE USED AS CIP PUMPS.

Non-compliance with this instruction may lead to rapid wear of cylinder and piston.

4.2 CIP circuit recommended

In all cases, the pressure at the pump inlet during cleaning must not exceed 3 barg (43,5 psig).

The flow through the pump required for optimal cleaning is 30 - 35 m³/h.

This flow corresponds to difficult cleaning (sticky and viscous products). It can be reduced for easier types of cleaning.

4.3 Pumps arranged in series

This type of assembly is preferred in all cases. It ensures optimal cleaning for the pump and makes use of the special design of the C Series, i.e. the possibility of lifting the piston with the cleaning product.

As the pressure at the pump inlet is higher than that at its outlet, the piston lifts from the cylinder and permits the passage of all the cleaning liquid through the C Series pump.

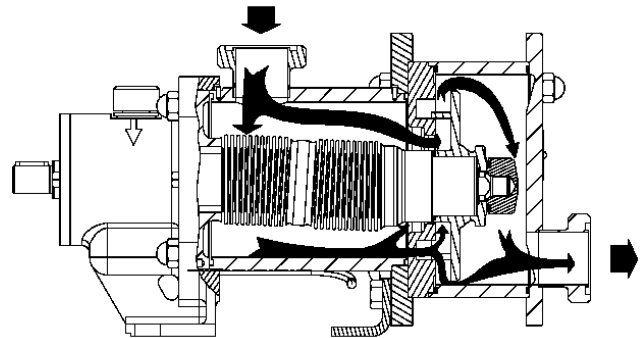

- A centrifuge pump is used for CIP cycles. This pump is placed upstream of the C Series pump.

The centrifuge pump must be installed in series with the C Series pump.

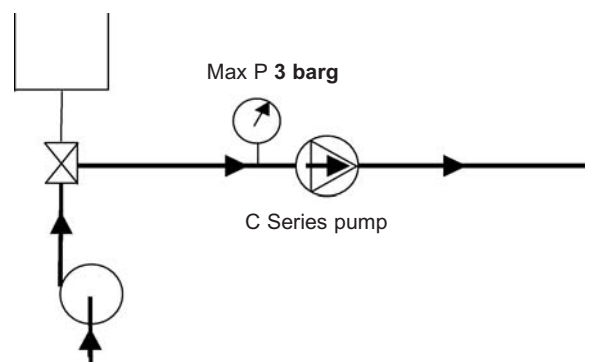

It is preferable not to run the C Series pump during CIP although low speed (< 100 rpm) is acceptable by alternating start/stop operation.

- In certain cases, the flow of the cleaning liquid required for the installation is higher than that recommended for cleaning the pump. In this case, a bypass must be used.

The bypass valve is adjusted to divide the flow between the circuit flowing through the C Series pump and the bypass circuit.

4. CLEAN IN PLACE (CIP) & STERILISATION IN PLACE (SIP) (continued)

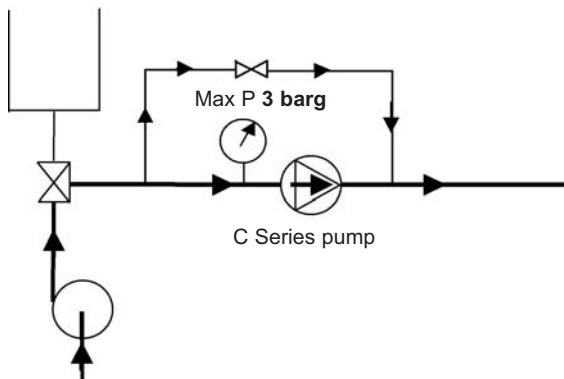

It is preferable not to run the C Series pump during CIP, although low speed (< 100 rpm) is acceptable by alternating start/stop operation.

- In certain cases, the cleaning pressure required for the installation is higher than 3 barg (43,5 psig). In this case, the use of a bypass is required and cleaning is done in 2 steps.

Cleaning the pump :

The cleaning flow should be limited during the cleaning of the C pump to ensure a maximum pressure of 3 barg (43,5 psig) at the C pump inlet.

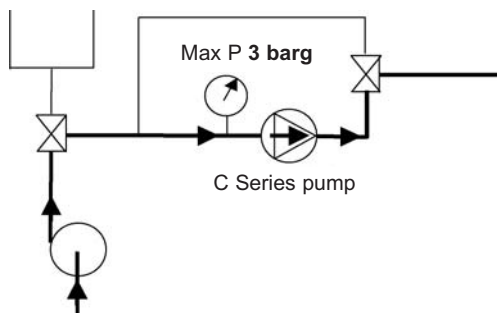

It is preferable not to run the C Series pump during CIP although low speed (< 100 rpm) is acceptable by alternating start/stop operation.

Cleaning the installation :

During this operation, the valve system used must ensure that no flow can pass through the pump so that the C Series pump does not rotate. Under these conditions, with the pump completely stopped, the pressure of the washing circuit can rise up to 6 barg (87 psig).

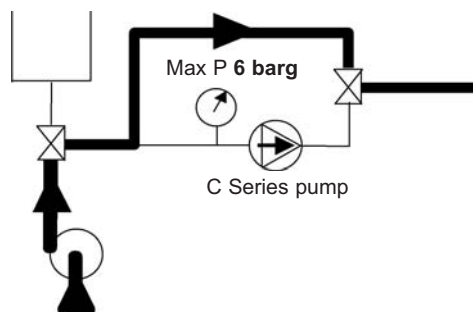

The pump must not run during this operation.

4.4 Pumps arranged in parallel

For applications where cleaning is easy and the differential pressure of, the C Series pump is lower than 2 bar (29 psi) during this operation, assembly in parallel is authorised. It should be noted that during cleaning, the C Series pump will be acting on a product with generally few lubricating properties. This will contribute towards wear of the pump.

The CIP centrifuge pump must never be installed in parallel with a C Series pump without taking special precautions.

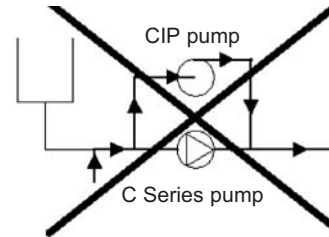

Indeed, in this case, the pressure at the inlet of the C Series pump is lower than the pressure at the discharge and the piston remains forced against the cylinder. Therefore, there the C Series pump no longer provides a passage. Its efficient cleaning can no longer be ensured and the cylinder/piston pair will become prematurely worn.

Authorised assembly :

As mentioned previously for applications where cleaning is easy, assembly in parallel is authorised when the valves are installed so that the cleaning pressure of the circuit does not come into contact with the C Series pump.

In this case, the C Series pump cleans itself.

Cleaning the pump :

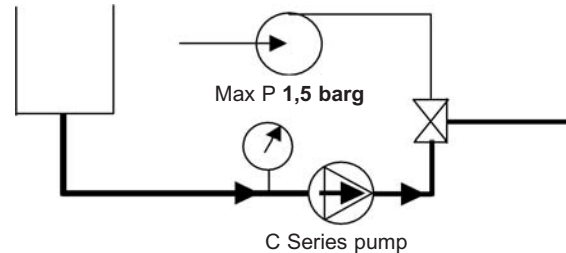

We recommend limiting the rotation speed of the C Series pump.

Cleaning the installation :

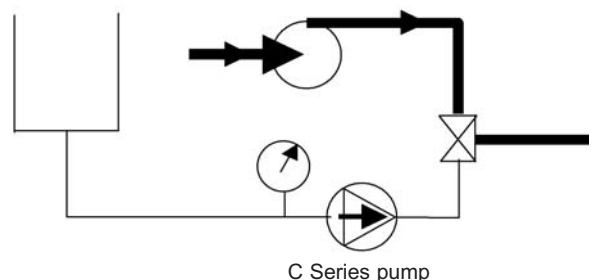

The C Series pump is stopped when cleaning the installation.

4. CLEAN IN PLACE (CIP) & STERILISATION IN PLACE (SIP) (continued)

4.5 Successive cycles

Generally, the most efficient CIPs comprise 5 stages :

1. Pre-washing with clean water

Water at room temperature. 10 to 15 minute cycle. This pre-wash enables evacuation of the remaining residues.

2. Washing with an alkaline detergent

Typically this is soda at 2,5% at a temperature of 80°C. 20 to 30 minute cycle. This wash particularly enables dissolving and evacuating grease and proteins.

3. Rinsing with clean water

Water at room temperature. 10 minute cycle. This rinse enables avoiding the mixture of 2 cleaning solutions.

4. Washing with an acid solution

Typically this is nitric acid at 2,5% at room temperature. 10 to 15 minute cycle. This wash particularly enables dissolving and evacuating proteins and inorganic salts.

5. Rinsing with clean water

Water at room temperature. Several 1 to 2 minute cycles. These rinses enable evacuating all traces of acid solution.

During all these CIP stages, the average speeds of the cleaning liquids in the pipes must be between 1,5 and 3 m/s.

4.6 Sterilisation In Place (SIP)

The serie C pumps are perfectly adapted to all processes using SIP (Sterilisation In Place) : pump stopped / maximum 30 min per cycle / 1 or 2 cycles per day.

5. MAINTENANCE

5.1 Necessary tools

- 24 Socket wrench
- 13-32 Open-end spanner
- Hub puller
- 70 Open-end spanner or Monkey wrench

Tightened torques :

- M8 : 18 Nm
- M16 : 100 Nm
- M24 : 200 Nm

6. OPENING OF THE PUMP

⚠ WARNING



Any unforeseen start-up can cause serious injuries or important material damages.

TAKE ALL NECESSARY MEASURES TO RENDER ANY START-UP, EVEN ACCIDENTAL, OF THE PUMP DURING THE WORK IMPOSSIBLE.

⚠ WARNING



Hazardous pressure can cause personal injury or property damage.

DISCONNECTING THE FLUID OR PRESSURE CONTAINMENT COMPONENTS DURING PUMP OPERATION CAN CAUSE SERIOUS PERSONAL INJURY, DEATH OR MAJOR PROPERTY DAMAGE.

⚠ CAUTION



Hazardous pressure can cause personal injury or property damage.

FAILURE TO RELIEVE SYSTEM PRESSURE PRIOR TO PERFORMING PUMP SERVICE OR MAINTENANCE CAN CAUSE PERSONAL INJURY OR PROPERTY DAMAGE.

⚠ WARNING



Hazardous or toxic fluids can cause serious injury.

IF PUMPING HAZARDOUS OR TOXIC FLUIDS, THE SYSTEM MUST BE FLUSHED PRIOR TO PERFORMING ANY SERVICE OPERATION.

⚠ WARNING



The weight of the parts can be dangerous and may provoke bodily injuries or material damages.

BE CAREFUL WITH THE WEIGHT OF THE PARTS WHEN THEY ARE BEING REMOVED.

⚠ CAUTION



Slippery lubricant. Spills should be cleaned up.

THE PUMP LUBRICANT IS VERY SLIPPERY AND MAY CAUSE SERIOUS INJURY. ANY SPILLS MUST BE CLEANED UP.

6.1 Assembly / Dismantling

Before any dismantling, make sure that the pump has been drained and take the necessary measures to avoid starting-up. No start-up, even accidental, must be allowed.

- Disconnect the pump from the discharge pipe.
- Unscrew the 6 nuts **106** and remove the 6 tierods **105-107**.

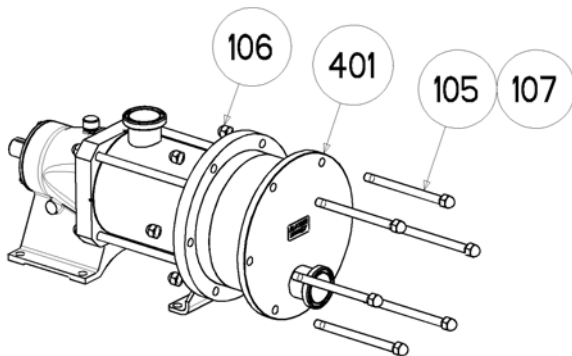

- Remove the front cover **401**.

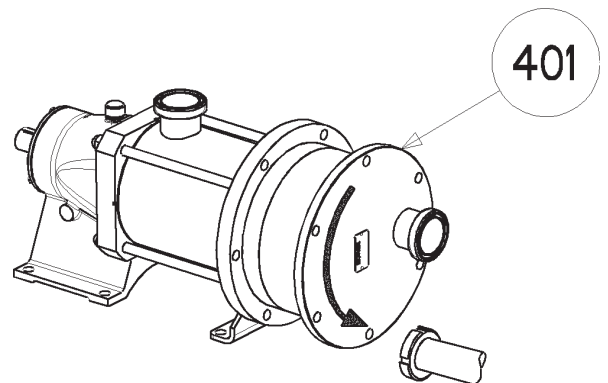

6. OPENING OF THE PUMP (continued)

- Remove the outlet tube **402** and its seals **205**.

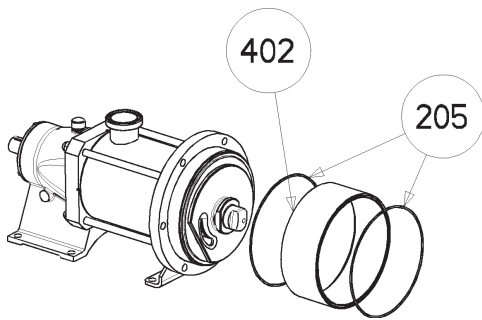

- Hold the piston **301** with a 70 Open-end spanner or a monkey wrench and unscrew the nut **304** and its seal **305**.

It is important to keep a good grip on the piston, its rotation could lead to deterioration of the bellows.

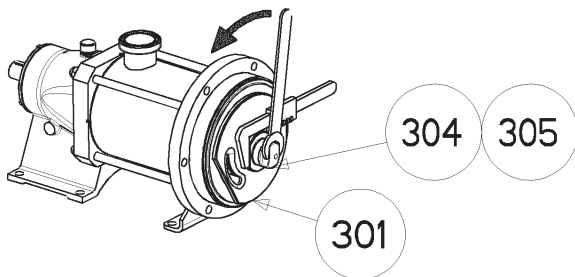

- With the help of a hub puller, extract the piston **301**.

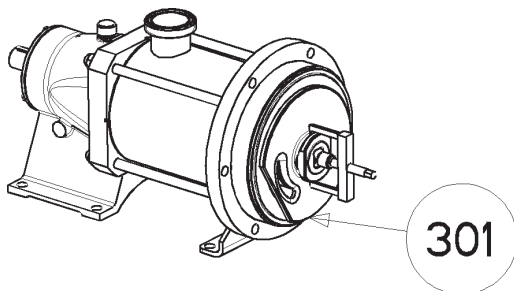

- Remove the cylinder **201** and the seals **113** and **306**.

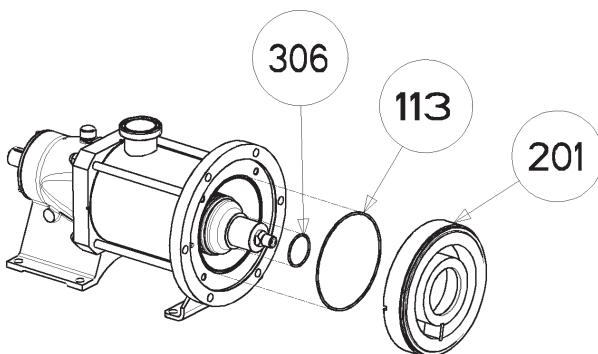

6.2 Checking of parts

The piston **301** and the cylinder **201** are active parts (wearing parts) on which the pump's efficiency directly depends. It is therefore advisable to regularly check the pump's efficiency and replace the cylinder / piston if it decreases.

In addition, as using a cylinder / piston that is too worn may damage the pump's transmission system, it is advisable to replace the cylinder / piston if the maximum acceptable wear dimensions defined in the table below are reached.

		Piston 301 mm (inch)	Cylinder 201 mm (inch)
C12	New dimension	9 (0,354)	50 (1,969)
	Minimum wear dimension acceptable	6 (0,236)	47 (1,850)
C18	New dimension	9 (0,354)	70 (2,756)
	Minimum wear dimension acceptable	6 (0,236)	67 (2,638)

As changes in the pump's efficiency depend on the conditions of use (pressure, rotation speed, liquid pumped, etc.), MOUVEX recommends that users define the monitoring ranges and the preventive maintenance schedule according to their own experience.

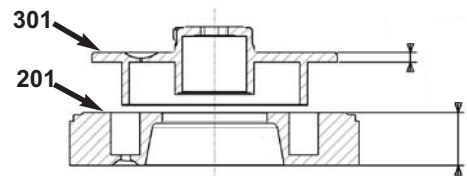

7. ASSEMBLY OF CYLINDER/PISTON

- Check the state of the seals **205**, **305**, **306**, **113** and replace them if necessary.
- Position the seal **113** on the large flange and the seal **306** on the hub.

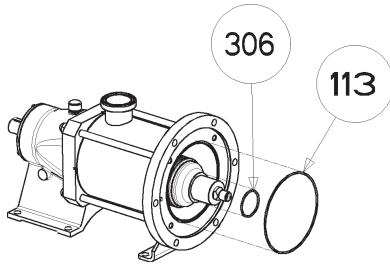

- Position the cylinder **201** such that the locating pin fits into the notch of the back of the cylinder.

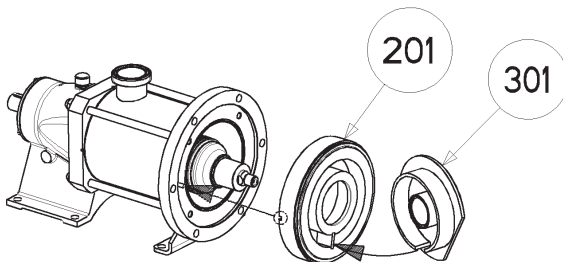

- Engage the piston **301** on the transmission hub **596**, the gap of the piston facing the cylinder partition.
- Give a small push to the piston to centre it and engage it in the cylinder, then push it tight to the end while ensuring the oblong hole of the piston is engaged on the 2 flats of the end of the transmission hub **596**.

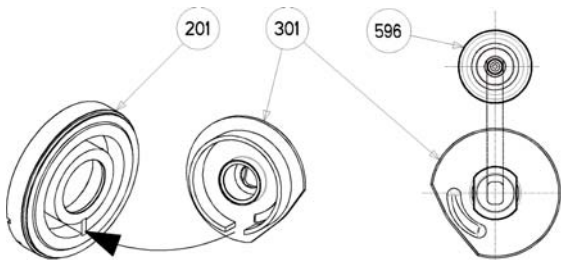

- Place thread locking adhesive (Loctite® 243* or equivalent) on the thread of the transmission hub **596**.

⚠ WARNING



BE CAREFUL WITH THE WEIGHT OF THE PARTS WHEN THEY ARE BEING REMOVED.

The weight of the parts can be dangerous and may provoke bodily injuries or material damages.

- Hold the piston **301** with a 70 Open-end spanner or a monkey wrench and screw-up the nut **304** after mounting the seal **305** on to the rear face.

It is important to keep a good grip on the piston, its rotation could lead to deterioration of the bellows. When tightening the nut, comply with the assembly torque of 200 Nm.

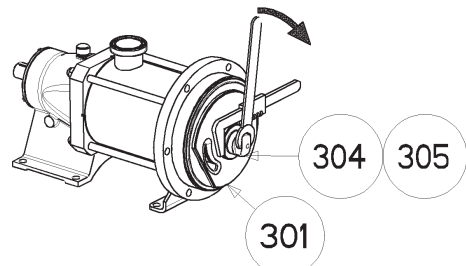
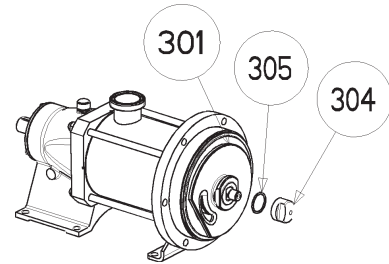

- Re-mount the outlet tube **402** with its 2 seals **205**.

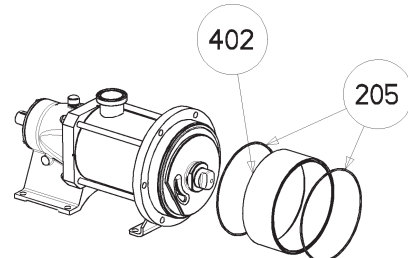

- Re-mount the front cover **401** while positioning the outlet port desired.
- Position the rods **105 -107** and screw up the 6 nuts **106** (6 x M16 assembly torque 100 Nm).

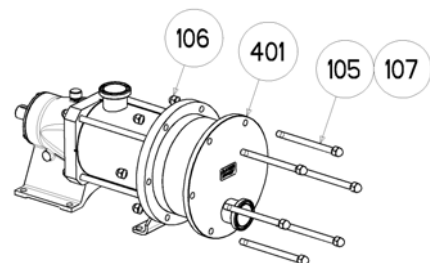

* Loctite® is a registered trademark.

8. PROTECTION OF THE BELLOWS



BE CAREFUL WITH THE WEIGHT OF THE PARTS WHEN THEY ARE BEING REMOVED.

- Dismantle the cylinder/piston couple (see corresponding §).
- Remove the 2 fixing screws from the base frame of the lug **108**.
- On the drive side, remove the 4 nuts **115**.

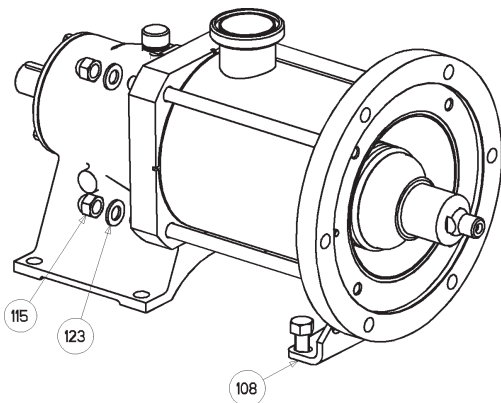

- With the help of a mallet, lightly tap the large flange **104** to free the tube **101** from the transmission hub **596**.
- Remove the tube **101** while taking care of impact.
- Remove the seal **113**.
- Inspect the bellows : any impact, scratch or distortion necessitates its replacement.

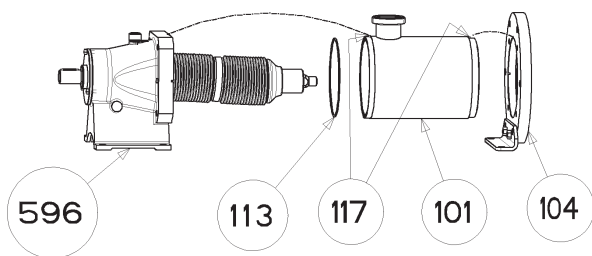

- Assembly is undertaken in the reverse order of dismantling, taking care to correctly position the seal **113** and the 2 indexing pins **117**. The nuts **115** must be re-mounted with thread locking adhesive (Loctite® 243* or equivalent) :
- 4 x M16 : Assembly torque 100 Nm.

Under preventive maintenance (every 150 millions of cycles duty), we suggest transmission replacement.

In this case : The transmission delivered is equipped with a tubular foam protection. We advise leaving this protection around the bellows until re-mounting of the piston and cylinder.



DO NOT FORGET TO REMOVE THE PROTECTION BEFORE MOUNTING THE CYLINDER.

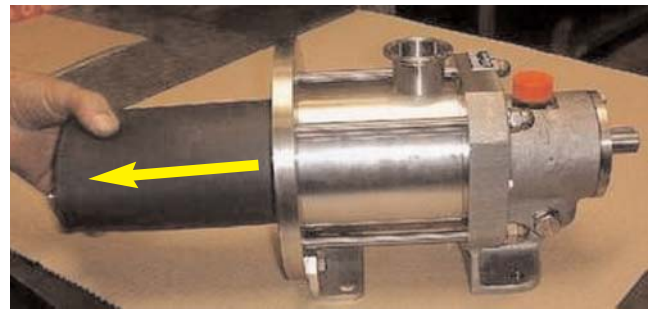

* Loctite® is a registered trademark.

9. CHANGING THE LIP SEAL



THE PUMP LUBRICANT IS VERY SLIPPERY AND MAY CAUSE SERIOUS INJURY. ANY SPILLS MUST BE CLEANED UP.

- Drain the pump bearing (see corresponding §).
- Remove the circlip **725**.
- Extract the 2 lip seals **608**.
- Check the gasket surface on the ring **507**.
- If the seal face is marked, change the ring **507**.
- Remove the seal **518**.
- Break the ring **507** with a chisel then fit a new ring after heating it at 95°C (in an oil bath or at HF).
- Place a new seal **518**.

- Fit the 2 seals **608**, lip directed towards the interior of the transmission.
- Put grease between the 2 seals **608**.



FOOD SYNTHETIC GREASE :
Compulsory reference because compatible with the standard MOUVEX bearing oil.

- Replace the circlip **725**.
- After replacing the drain bung, fill the bearing with 4 litres of oil*. See § DRAINING OF BEARING..
- Screw back the breather **715**. on the lubrication container for the HT version or on the bearing on the standard version

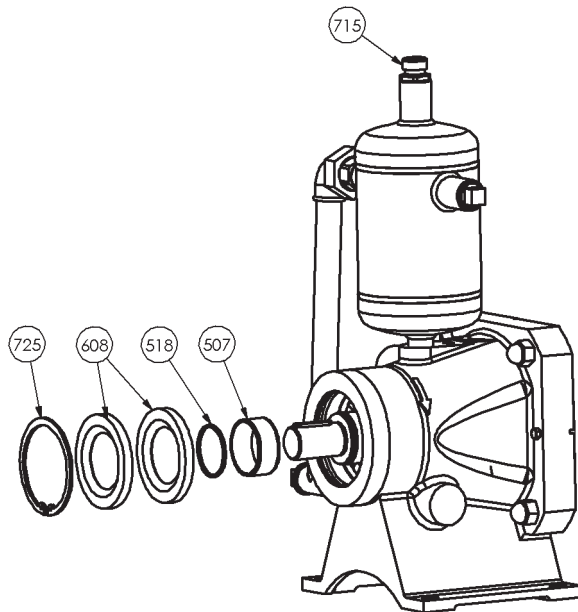

* Standard oil provided by MOUVEX : CS05 Food synthetic oil (Safety data sheet is supplied with the new pump and on inquiry).

* Other oil provided by customer.

10. CHANGING THE ORIENTATION OF THE PORTS



BE CAREFUL WITH THE WEIGHT OF THE PARTS WHEN THEY ARE BEING REMOVED.

10.1 Discharge port

- Unscrew the 6 nuts **106** and remove the 6 rods **105-107**.
- Turn the front cover **401** so as to position the outlet port in the desired position.
- Replace the 6 rods **105-107** and tighten the nuts **106**.
- Make sure that the seal **205** is secured in its housing. Secure it with a grease that is compatible with the transferred product if necessary.

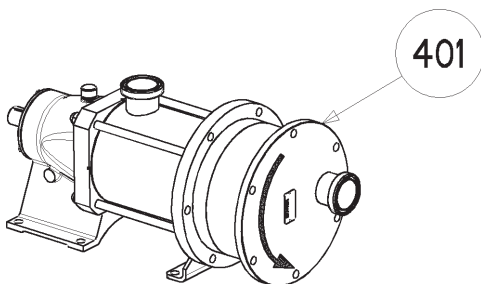
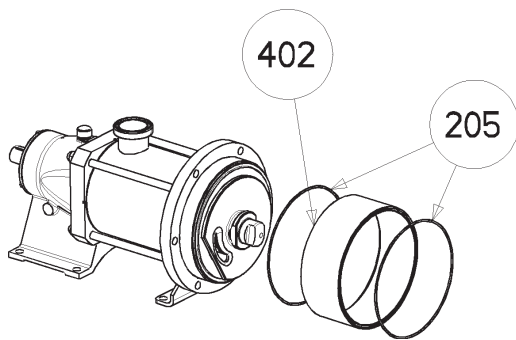
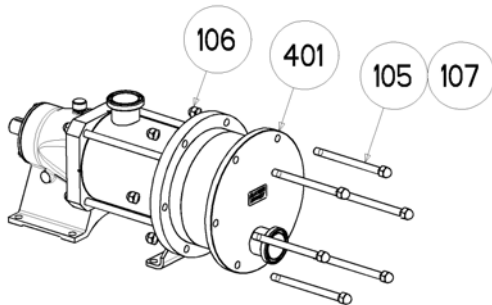

10.2 Suction port

- Dismantle the main body **101** including the suction port as indicated in the corresponding §.
- Re-mount the main body **101** in the desired position by fitting the indexing pins **117** in the housings provided in the bearing **596** and the flange **104**.
- Make sure that the seal **113** is secured in its housing. Secure it with a grease that is compatible with the transferred product if necessary.

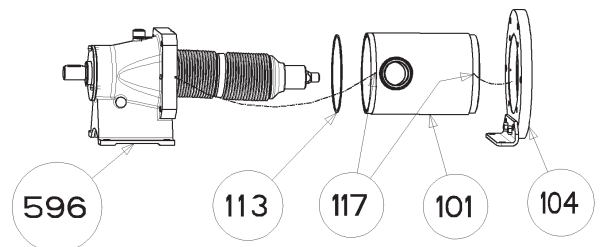
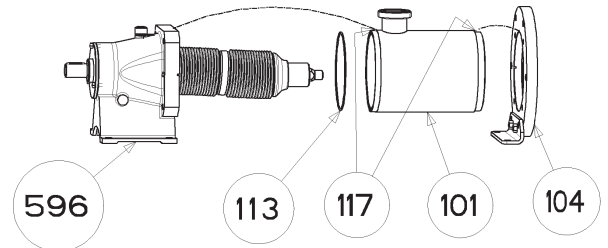

11. DRAINING OF BEARING

CAUTION



Slippery lubricant. Spills should be cleaned up.

THE PUMP LUBRICANT IS VERY SLIPPERY AND MAY CAUSE SERIOUS INJURY. ANY SPILLS MUST BE CLEANED UP.

- Screw back the breather 715.

C12 i - C18 i

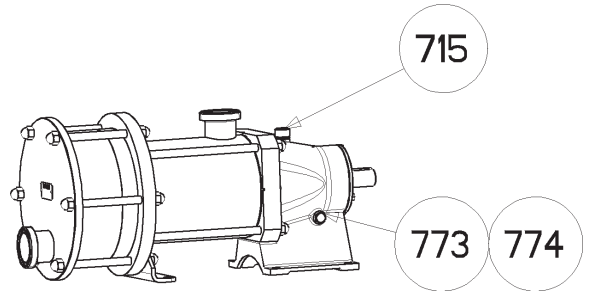

C12 i HT - C18 i HT

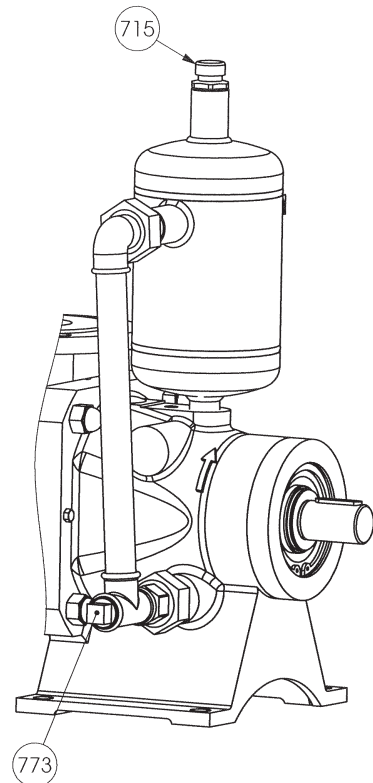

- Drain the transmission following the board below :

- **Data with standard MOUVEX oil :**

Temperature of product pumped / heating product	Draining interval (running hours)
150 °C < T ≤ 160 °C	800
135 °C < T ≤ 150 °C	1 500
120 °C < T ≤ 135 °C	3 000
100 °C < T ≤ 120 °C	6 000
80 °C < T ≤ 100 °C	12 000
T ≤ 80 °C	24 000

- **Data with other customer oil :** the drawing interval is defined by the customer (tests results) regarding the oil specifications and the pump conditions.

- Drain the pump by removing the drain bung with its seal 773-774 (C12 i - C18 i) and the breather 715.
- Replace the drain bung and its seal.
- Fill the transmission with :
 - 2 litres of oil (C12 i - C18 i)*.
 - 4 litres of oil (C12 i HT - C18 i HT)*.
- Check oil level that the level is between 1 and 5 mm above the shaft.

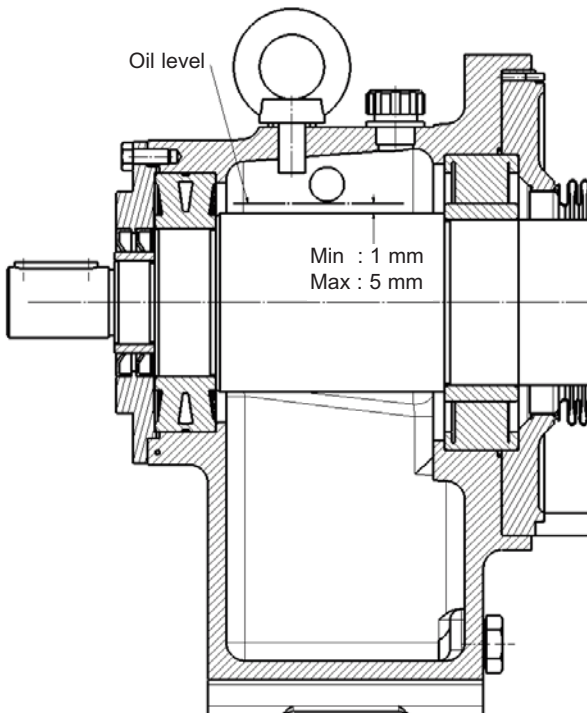

* Standard oil provided by MOUVEX : CS05 Food synthetic oil (Safety data sheet is supplied with the new pump and on inquiry).

* Other oil provided by customer.

12. OPTIONS

12.1 Liquid detector

The liquid detector works with single and double ply bellows. It is installed on the vent circuit (see § PROTECTION OF THE PUMP INSTALLATION).

In case of flooded suction or during the cleaning process, a bellows puncture will fill the transmission with liquid. The liquid detector will inform the user when a bellows puncture occurs.

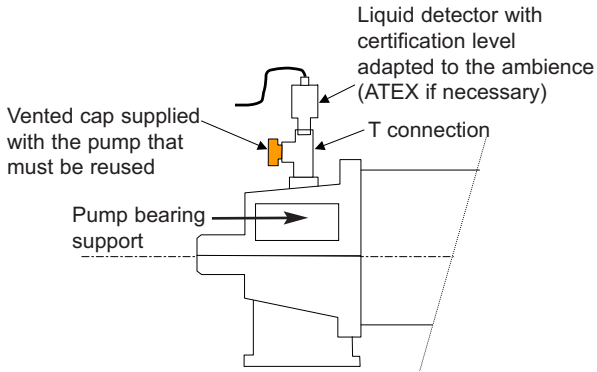

12.2 Bellows monitoring system

The bellows monitoring system called (BMS) works only with double ply bellows.

Working principle : During the transmission assembly, a gas pressure (argon) is introduced in between the bellows ply. A pressure switch or pressure gauge is connected on the bellows's gas filling cavity and all the circuit is sealed. This operation is done by the factory and any technical operation will break the sealings (see picture) and avoid the warranty.

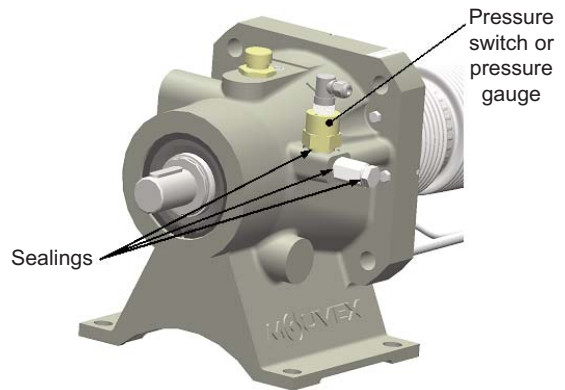

The gas pressure is 0,2 bar (2,9 psi) above the maximum acceptable pressure on the bellows under working condition.

Any puncture in either one of the two metallic bellows leads to a pressure drop. When the pressure decrease under the pressure switch setting, it cuts the electrical circuit.

To connect the electrical pressure switch, follow the manufacturer instruction.

13. CERTIFICATE OF CONFORMITY



CERTIFICATE OF CONFORMITY CE

MOUVEX, Z.I. La Plaine des Isles - Rue des Caillottes - 89000 AUXERRE FRANCE, declares the following equipment :

Set-up : Pump / Compressor « bare-shaft » Pumping Unit / Compressor Unit
Type : Eccentric Disc Pump Vanes Pump Lobes Pump
 Peristaltic Pump Centrifugal Pump Other Pump
 Screws compressor Vanes compressor Hydraulic cooler

Designation : _____ s/n° : _____

According to the specifications recorded in the file N° : _____

is in conformity with the provisions of the following Directive :

- « **MACHINES** » Directive 2006/42/EEC as transposed by the national legislation, concerning safety equipments and arrangements relative to mechanical and electric risks applicable to rotative machines.
NF EN 809:2009 NF EN 1672-2:2009 NF EN ISO 13857:2008 NF EN 12162:2009

And with the following marking :  II2 G c IIB-T4 Max T° Flow = 80°C

is in conformity with the provisions of the following Directive :

- « **ATEX** » Directive 94/9/EC (23 march 1994) as transposed by the national legislation, concerning equipment intended to be used in explosive atmospheres. Conformity obtained by application of the standards :
NF EN 1127-1:1997 NF EN 13463-1:2009 NF EN 13463-5:2009

ATEX Certification delivered by INERIS, Notified Body (INERIS - Parc Technologique Alata - 60550 Verneuil-en-Halatte - France).

The equipment indicated above must be used according to the foreseen use by its design and its manufacturing, and according to the current standards.

We, undersigned, declare that the concerned equipment is in conformity with the Directives listed above and in the applicable standards in force.

For MOUVEX SAS Company.
Date : _____



Quality Manager

MOUVEX sas : Z.I. La Plaine des Isles - 2, rue des Caillottes - 89000 AUXERRE - France - SAS au capital de 8 496 855 €
Tél : (33) 3.86.49.86.30 - Fax : (33) 3.86.46.42.10 - RCS AUXERRE 389 236 548 - APE 291 B - FR 85 389 236 548
www.mouvex.com