

C12 A - C18 A PUMPS



INSTALLATION

OPERATION

MAINTENANCE

ECCENTRIC PISTON PUMP

MOUVEX PRINCIPLE

SAFETY INSTRUCTIONS, STORAGE, INSTALLATION AND MAINTENANCE

MODELS : C12 A - C18 A

TECHNICAL CHARACTERISTICS

- Maximum pump speed : **530 rpm**
- Maximum running temperature : **100°C**
- Maximum suction pressure :
 - In normal use, the suction pressure must be higher than the required NPSH and **less than 1,5 barg** (21,75 psig).
 - Pump **stopped**, the pressure must not exceed **6 barg** (87 psig).
- Acceptable maximal differential pressure :
 - C12 A.....9 bar (130,5 psi)*
 - C18 A.....6 bar (87 psi)*
- Maximum pressure jacket : **8 barg** (116 psig)
- Cylinder capacity :
 - C12 A.....0,411 litre
 - C18 A.....0,617 litre

* When the pump works with an inlet gauge pressure less than zero, the maximum outlet pressure will be calculated as if the inlet pressure is equal to zero.

SAFETY INFORMATIONS



This is a SAFETY ALERT SYMBOL

When you see this symbol on the product, or in the manual, look for one of the following signal words and be alert to the potential for personal injury, death or major property damage.



Warns of hazards that **WILL** cause serious personal injury, death or major property damage



Warns of hazards that **CAN** cause serious personal injury, death or major property damage.



Warns of hazards that **CAN** cause personal injury or property damage.

NOTICE

Indicates special instructions which are very important and must be followed.

USED PRESSURE UNITS

Unit without suffix :

Differential pressure, for example, pressure difference between equipment suction and discharge.

Unit with suffix "a" :

Absolute pressure.

Unit with suffix "g" :

Gauge pressure, given regarding to atmospheric pressure (~101325 Pa, taken at 1 bar / 14,5 psi in this IOM).

Example :

Psuc = -0,2 barg = 0,8 bara

Pdis = 8,8 barg = 9,8 bara

$\Delta P = Pdis - Psuc = 9 \text{ bar}$

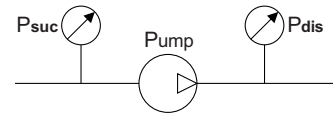

TABLE OF CONTENTS

Page

1. OVERALL DIMENSIONS	3
2. INSTALLATION	6
2.1 Orientation of the pump ports	6
2.2 Direction of rotation	6
2.3 Protection of the pump installation	6
2.4 Hoisting devices	7
2.5 Unit Assembly	7
3. UTILISATION	9
3.1 Noise level	9
3.2 Commissioning	9
3.3 Dry running	9
3.4 Pump stop	10
3.5 Scrapping	10
4. MAINTENANCE	10
4.1 Necessary tools	10
5. OPENING OF THE PUMP	10
5.1 Assembly / Dismantling	11
5.2 Checking of parts	12
6. REASSEMBLY OF CYLINDER/PISTON	13
7. PROTECTION OF THE BELLOWS	14
8. CHANGING THE LIP SEALS	15
9. CHANGING THE ORIENTATION OF THE DISCHARGE PORT	15
10. BYPASS	16
10.1 Bypass adjustment	16
10.2 Changing the spring	16
10.3 Replacement of the seals	16
11. HEATING JACKET (OPTION)	17
11.1 Replacement of the jacket seal	17
11.2 Bleed (included with jacket option)	17
12. DRAINING OF BEARING	18
13. OPTIONS	19
13.1 Liquid detector	19
13.2 Bellow monitoring system	19
14. CERTIFICATE OF CONFORMITY	20

1. OVERALL DIMENSIONS

C12 A - C18 A

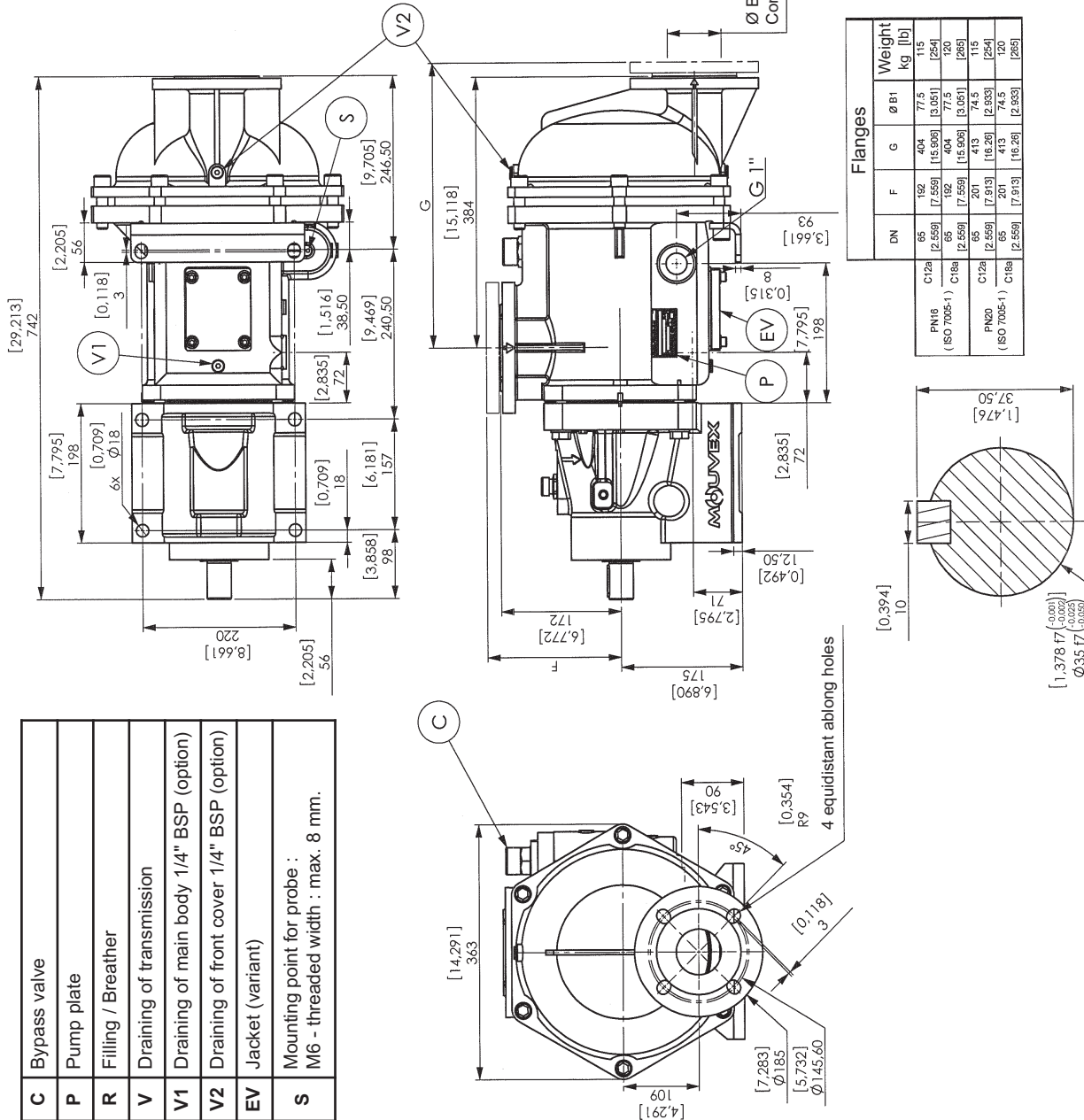
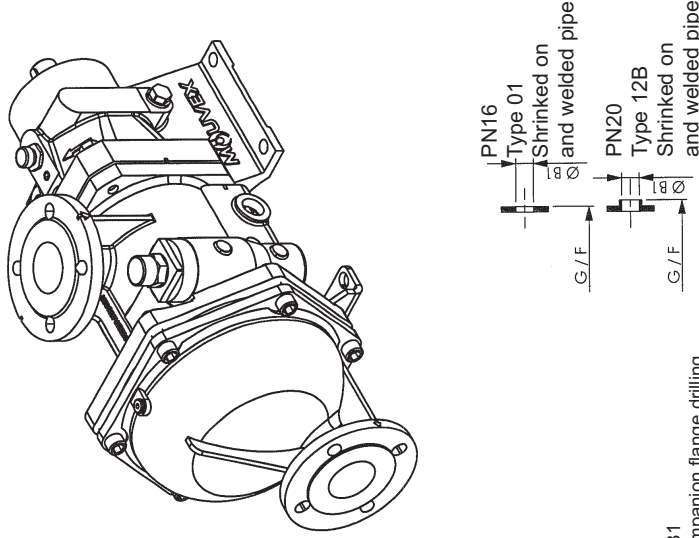

Flanges		DN	F	G	Ø E1	Weight kg [lb]
C12a	PN16 (ISO 7005-1)	65	192	404	77,5	115
		65	[2,559]	[15,926]	[3,051]	[254]
C18a	PN16 (ISO 7005-1)	65	192	404	77,5	120
		65	[2,559]	[15,926]	[3,051]	[265]
C12b	PN20	65	201	413	74,5	115
		65	[2,559]	[16,226]	[2,933]	[254]
C18b	PN20	65	201	413	74,5	120
		65	[2,559]	[16,226]	[2,933]	[265]

C	Bypass valve
P	Pump plate
R	Filling / Breather
V	Draining of transmission
V1	Draining of main body 1/4" BSP (option)
V2	Draining of front cover 1/4" BSP (option)
EV	Jacket (variant)
S	Mounting point for probe : M6 - threaded width : max. 8 mm.

Bellows monitoring system C12 - C18

1. OVERALL DIMENSIONS (continued)

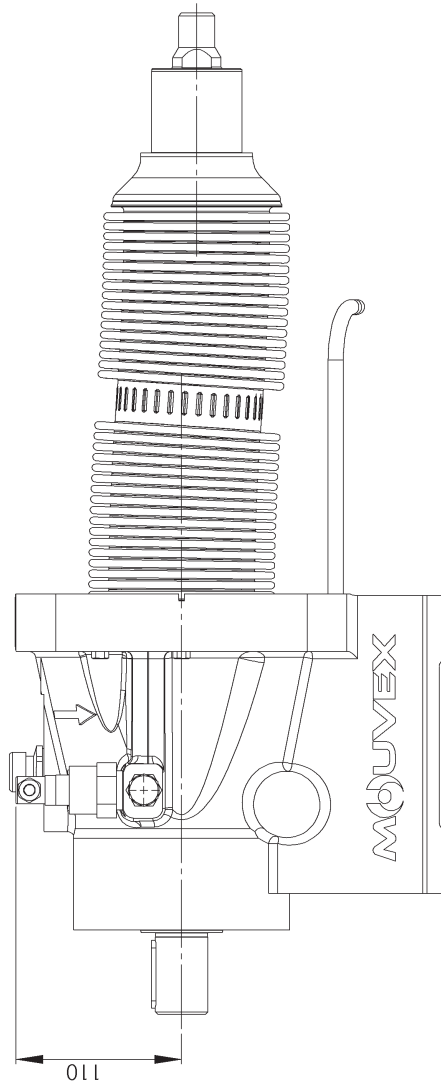
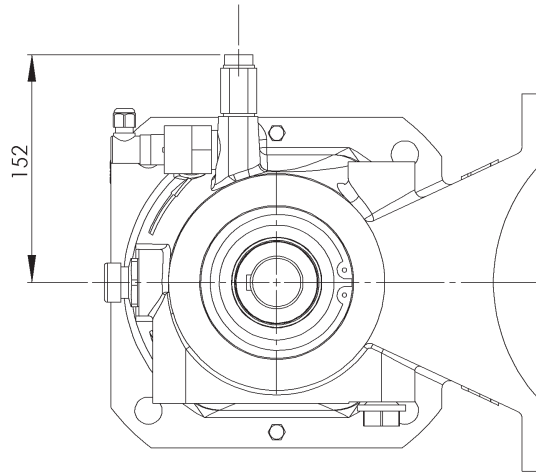

CAUTION :
A BAD CONNECTION CAN
DESTROY THE SENSOR.

Wiring diagramm
Connector
Do not use S2

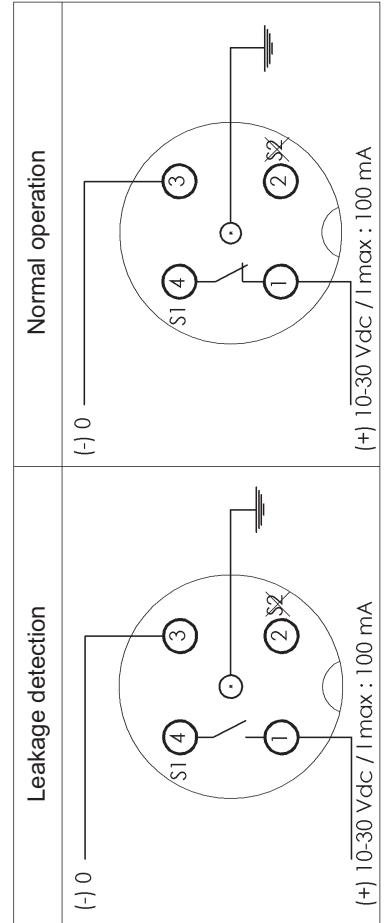

NOTA :
Setting of detection levels is done in factory and do not have to be modified.
For other dimensions, report to pump dimensional drawing.
The dismantling of the transmission could be done only in factory.

1. OVERALL DIMENSIONS (continued)

Bellows monitoring system ATEX C12 - C18

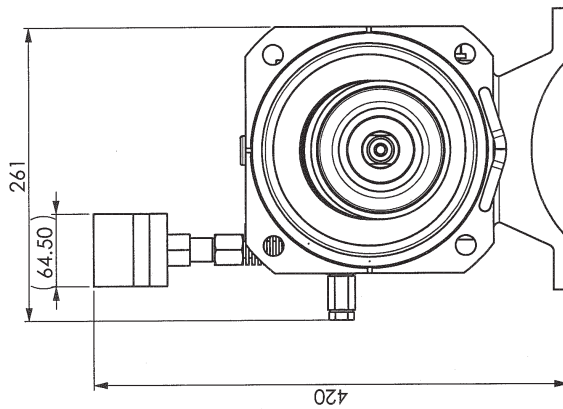
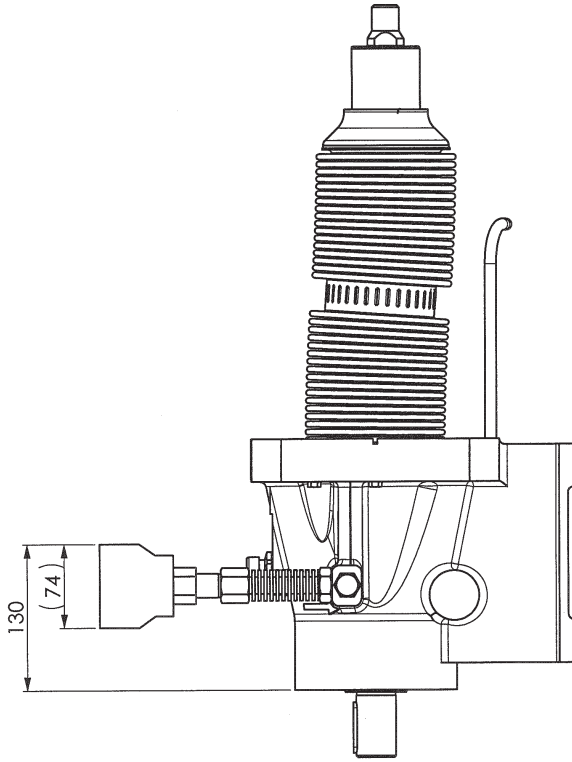

NOTA :
Setting of detection levels is done in factory and do not have to be modified.
For other dimensions, report to pump dimensional drawing.
The dismantling of the transmission could be done only in factory.

Connection diagram

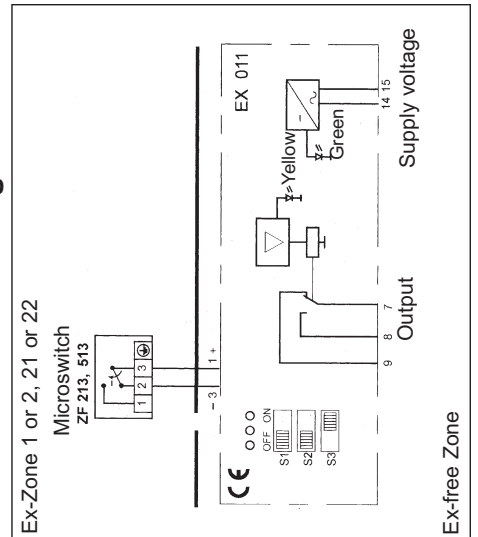

With falling pressure 3-2 opens.

CAUTION :
Incorrect connection can lead to :
- a flammability risk,
- ineffective monitoring,
- possible damage to the sensor.

2. INSTALLATION

POSSIBLE POSITIONS

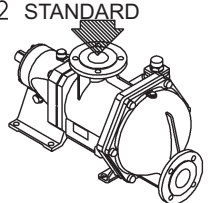
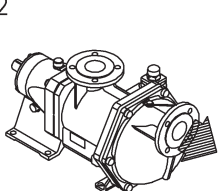
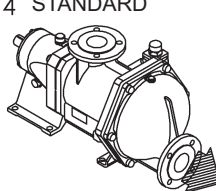
SUCTION	2 STANDARD 	
DISCHARGE	2 	4 STANDARD 

JACKET CONNECTION (variant)

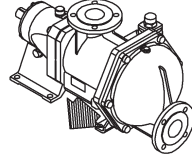
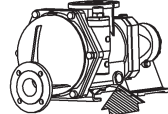
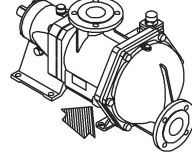
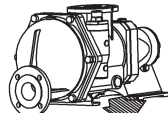
1" CYLINDER GAS	
LIQUID	 
STEAM	 

The C Series pump is a selfpriming volumetric PD pump.

Therefore, the pump must not run on a circuit with a closed valve. This is valid both for the suction circuit and for the discharge circuit.

2.1 Orientation of the pump ports

The discharge port may be oriented in various positions.

If the port positions needs to be changed at any time, see the corresponding paragraph.

NOTICE

C-Series pumps remains drainable whatever position is chosen for the inlet port, but the outlet port must be at the bottom (position 4) to keep the self-draining capability.

2.2 Direction of rotation

When looking at the shaft, the rotation will be clockwise. When looking at the front cover, the direction of rotation will be anti-clockwise. An arrow situated on the bearing housing indicates the correct direction of rotation.



Verification of the correct rotation direction :

Turn the pump the wrong way is not dangerous for the pump.

2.3 Protection of the pump installation

- For ease of maintenance, it is a good idea to place isolation valves before and after the pump. The sizing of these valves must correspond to the diameter of the pipes.
- Before any start-up, during operation or complete stopping of the pump, make sure the valves are open.
- During stop periods, with the pump full of product, either the suction or discharge circuit must be left open to enable expansion or contraction of the pumped product through reheating or cooling. If this instruction is not complied with, The bellows may be damaged and lead to premature failure.
- The bearing must be ventilate at all times, therefore the breather mounted on the bearing must be re-used. Never put the bung on.
- In case of flooded suction, it is possible to install a liquid detector in the place of the transmission breather (see § options). This detector will enable the user to be informed in the case of failure of the bellows. In the case of detection, the installer must make sure the pump is stopped and the isolating valves are closed. Non compliance with this instruction can lead to the pumped product being spilt outside the pump.
- It is possible to have a puncture detection system with double-walled bellows : an inert gas is maintained under pressure between the 2 walls and said pressure is permanently monitored. A signal is dispatched immediately should a wall become punctured (see § OPTIONS).
- The stop time may lead to cooling of the product in the pump and therefore to an increase in viscosity. If this is the case, we recommend re-starting the pump at a speed adapted to this new viscosity (starting pump). Once the product arrives in the pump at the installation definition temperature, the pump may run at the speed specified for this application.

2. INSTALLATION (continued)

- Protection against excess pressure :

The pump must be protected against excess pressure. It can be delivered with a pressure switch to carry out this function.

If protection is provided by a control valve, check that the system does not generate excess pressure at the bellows (particularly if there are water hammers). Operating in this way would damage the bellows and shorten their lifetime.

⚠ CAUTION

Hazardous pressure can cause personal injury or property damage.

INCORRECT SETTINGS OF THE PRESSURE RELIEF VALVE CAN CAUSE PUMP COMPONENT FAILURE, PERSONAL INJURY, AND PROPERTY DAMAGE.

⚠ CAUTION

Hazardous pressure can cause personal injury or property damage.

FAILURE TO INSTALL ADEQUATELY SIZED PRESSURE RELIEF VALVE(S) CAN CAUSE PROPERTY DAMAGE, PERSONAL INJURY OR DEATH.

⚠ CAUTION

Hazardous pressure can cause personal injury or property damage.

PUMPS OPERATING AGAINST A CLOSED VALVE CAN CAUSE SYSTEM FAILURE, PERSONAL INJURY AND PROPERTY DAMAGE.

- Protection against foreign bodies :

The pump and the installation must also be protected against any risk of damage through the passage of foreign bodies by mounting a pre-filter at the pump suction.

In the case of foreseeable clogging of the pre-filter, we recommend using a vacuum switch to inform the user of pre-filter clogging. Prolonged running under cavitation may damage the pump.

2.4 Hoisting devices

Hoisting points :



2.5 Unit Assembly

The following instructions apply to pumps delivered with a bare shaft or for MOUVEX motor-driven pump units (if the latter have no specific instruction notice).

2.5.1 INSTALLATION OF UNITS

⚠ WARNING

The weight of the parts can be dangerous and may provoke bodily injuries or material damages.

BE CAREFUL WITH THE WEIGHT OF THE PARTS WHEN THEY ARE BEING REMOVED.

⚠ WARNING

Dangerous voltage. Can cause injury and death.

DISCONNECT THE ELECTRICITY SUPPLY BEFORE ANY MAINTENANCE OPERATION.

The base below the unit is fundamental to ensuring correct operation and long service life.

The unit's base must be flat, level and sufficiently resistant to absorb the stresses caused by the motor-driven pump unit without deformation (if it is made of concrete, it must comply with the BAEL 91 standard).

If the unit is fastened using securing lugs or bolts, it must be carefully wedged to avoid deforming the frame while the bolts are tightened. A deformed frame would apply damaging stresses on the pump and the drive mechanism and misalign the coupling, causing vibrations, noise and premature wear. Ensure that the frame is well above the floor, except from the support plates.

2. INSTALLATION (continued)

If the unit is to be used in a food environment, support plates that allow the unit to be lifted for easier cleaning are recommended.

Allow, if possible, a clear space of approximately 50 cm on each side of the motor-driven pump unit (overall dimensions) to facilitate cleaning and give access if necessary to the pump, reduction gear and motor fastening nuts. In all cases, the dimensions around the motor-driven pump unit must be designed to give the space required for dismantling the pump (if the need arises, use the values given on the overall dimension drawing).

For staff and equipment protection, the frame includes a ground connection point that should be used.

2.5.2 ALIGNMENT OF THE MOTOR/PUMP OR REDUCTION GEAR/PUMP SHAFTS

⚠ WARNING

Do not operate without guard in place.

IF OPERATED WITHOUT THE SHAFT GUARD, THERE IS CONSIDERABLE RISK OF SEVERE PERSONAL INJURY, SIGNIFICANT PROPERTY DAMAGE OR EVEN DEATH.

⚠ WARNING

Dangerous voltage. Can cause injury and death.

DISCONNECT THE ELECTRICITY SUPPLY BEFORE ANY MAINTENANCE OPERATION.

NEVER START A UNIT IF THE COUPLING ALIGNMENT IS INCORRECT. THIS IS A CONDITION OF OUR GUARANTEE.

REMINDER :

Coupling must never be used to compensate for a misalignment.

To control the alignment between the coupling and the shaft, use a straight-edge for concentricity and thickness gauges for angular misalignment (see instructions of the coupling for authorised values).

The 3 figures below show in detail the operation and the possible defects :

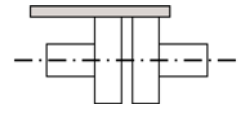
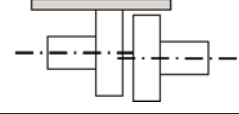
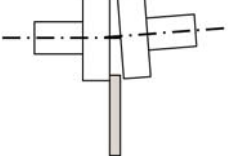
<i>Make this check for 4 points: up - down - left - right</i>	
	<i>Correct</i>
	<i>Out-of-parallelism</i>
	<i>Angular defect</i>

Controlling the alignment at each stage of the installation is important to be sure that none of these stages have generated stresses on the unit or the pump :

- after fastening on the foundations.
- after fastening the pipes.
- after the pump has been operated at the normal operating temperature.

Where the pumps are supplied assembled as a unit, the motor and pump shafts have been perfectly aligned in the factory before delivery, but they must be systematically controlled on acceptance at the site and realigned if necessary.

To do this, do not modify the wedging of the various parts, but check the flatness of the support surface and use the adjustable foot to clear the frame of stresses that could affect it.

2.5.3 ELECTIC MOTORS

⚠ WARNING

Dangerous voltage. Can cause injury and death.

DISCONNECT THE ELECTRICITY SUPPLY BEFORE ANY MAINTENANCE OPERATION.

Check the compatibility of the instructions on the motor with the supply voltage.

Follow the wiring diagram, use wiring that is appropriate for the power and be particularly careful about the contacts which must be well tightened.

The motors should be protected with circuit breakers and suitable fuses. Connect the regulatory electrical grounding.

2. INSTALLATION (continued)

2.5.4 THERMIC MOTORS



THE SURFACES CAN BE AT A TEMPERATURE LIABLE TO CAUSE INJURY OR SEVERE DAMAGE.

Do not forget that these motors are not reversible. It is absolutely necessary to carefully control the suction and discharge sides of the pump before connecting the group to the piping.

Using electric motors is very common now; however, we strongly advise careful reading of the accompanying instruction manual.

2.5.5 CONTROL OF THE SENSE OF ROTATION



TAKE ALL NECESSARY MEASURES TO RENDER ANY START-UP, EVEN ACCIDENTAL, OF THE PUMP DURING THE WORK IMPOSSIBLE.

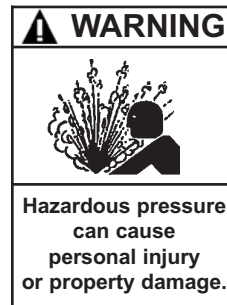

IT IS IMPERATIVE THAT THE HYDRAULIC PRESSURE IS RELEASED BEFORE EACH MAINTENANCE OPERATION TO AVOID PERSONAL INJURY OR MATERIAL DAMAGE.

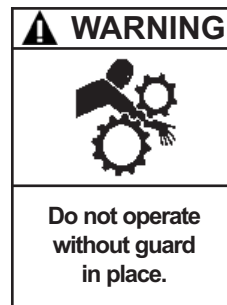

A DRIVE SHAFT GUARD BETWEEN THE PTO AND PUMP MUST BE PROVIDED TO PREVENT PERSONAL INJURY, PROPERTY DAMAGE, OR DEATH.

This control needs to be done with no liquid pumped through the pump, and both the suction and discharge circuits venting to avoid generating unexpected pressure (at the suction side, for example). This will ensure that the control will not damage either the pump or the installation.

Start the pump empty to check that the connections are good and that the direction of rotation corresponds to the suction and discharge direction on the installation. If it is necessary to reverse the direction of rotation, follow the instructions below :

Three-phase motor : switch any 2 current input wires.

Bi-phase motor : switch two same phase wires.

Single-phase motor : follow the instructions on the notice supplied with the motor.

3. UTILISATION

3.1 Noise level

The sound level of a pump is greatly influenced by its conditions of use. Cavitation and pumping products with high gas contents generally increases the sound level.

Under the following pumping conditions :

- excluding cavitation
- discharge pressure :
 - C12 : 9 bar (130,5 psi)
 - C18 : 6 bar (116 psi)
- speed of rotation 530 rpm
- product viscosity of 1 cSt

The sound level reached for the C12 / C18 pump in good conditions without the drive is less than 81 dB(A).

3.2 Commissioning

Make sure that the circuit valves are open before starting the pump.

To avoid any risk of polluting the product to be pumped, rinse the whole installation before starting-up so as to eliminate any contaminants that may remain in the piping, tanks etc. at the time of installation.

For any pure water pumping during process or cleaning operations, consult Mouvex imperatively.

3.3 Dry running

The C series pump is self priming and is capable of emptying the pipes. To do this, it can run dry for a maximum duration of 5 minutes.

3. UTILISATION (continued)

3.4 Pump stop

So as not to damage the pump, make sure that the pump is completely stopped before closing the valves.

3.5 Scrapping

The pump must be scrapped in compliance with the regulations in force.

During this operation, particular care must be paid to the drainage stages of the pump (pumped product) and of its transmission (lubricant).

4. MAINTENANCE

4.1 Necessary tools

- Hexagonal socket wrench no. 6-8-14
- 13-21-32-38 Open-end spanner
- Monkey spanner (opening 70 mm)
- Hub puller
- Mallet

Tightened torques :

- M8 : 18 Nm
- M16 : 100 Nm
- M24 : 200 Nm

5. OPENING OF THE PUMP



TAKE ALL NECESSARY MEASURES TO RENDER ANY START-UP, EVEN ACCIDENTAL, OF THE PUMP DURING THE WORK IMPOSSIBLE.



DISCONNECTING THE FLUID OR PRESSURE CONTAINMENT COMPONENTS DURING PUMP OPERATION CAN CAUSE SERIOUS PERSONAL INJURY, DEATH OR MAJOR PROPERTY DAMAGE.

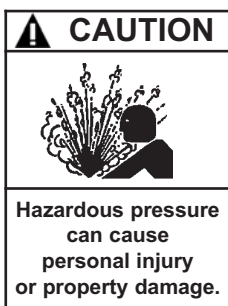

FAILURE TO RELIEVE SYSTEM PRESSURE PRIOR TO PERFORMING PUMP SERVICE OR MAINTENANCE CAN CAUSE PERSONAL INJURY OR PROPERTY DAMAGE.

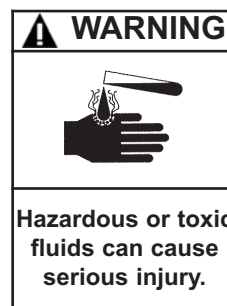

IF PUMPING HAZARDOUS OR TOXIC FLUIDS, THE SYSTEM MUST BE FLUSHED PRIOR TO PERFORMING ANY SERVICE OPERATION.



BE CAREFUL WITH THE WEIGHT OF THE PARTS WHEN THEY ARE BEING REMOVED.

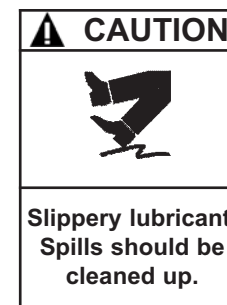

THE PUMP LUBRICANT IS VERY SLIPPERY AND MAY CAUSE SERIOUS INJURY. ANY SPILLS MUST BE CLEANED UP.

5. OPENING OF THE PUMP (continued)

5.1 Assembly / Dismantling

Before any dismantling, make sure that the pump has been drained and take the necessary measures to avoid starting-up. No start-up, even accidental, must be allowed.

- Hold the piston 301 with a monkey wrench (opening 70 mm) and unscrew the nut 304 and its seal 305.

It is important to keep a good grip on the piston, its rotation could lead to deterioration of the bellows.

- Disconnect the pump from the discharge pipe.
- Unscrew the 6 screws 106.
- Remove the front cover 401

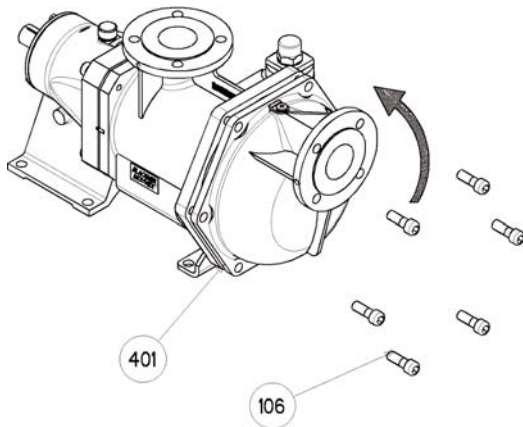

- With the help of a hub puller, extract the piston 301.

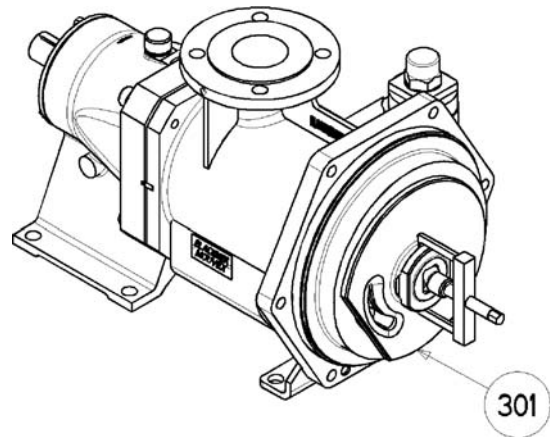

- Remove the front cover 401 with its seal 205.

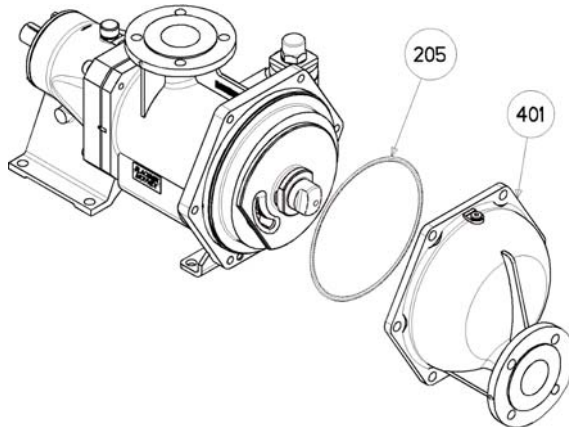

- Remove the cylinder 201 and the seals 113, 306 and 307.

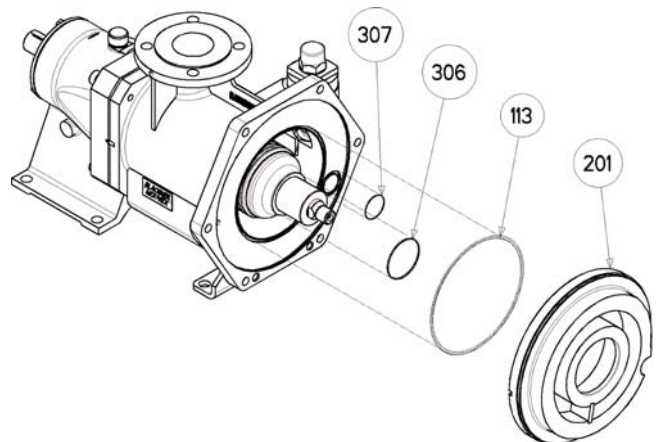

5. OPENING OF THE PUMP (continued)

5.2 Checking of parts

The piston **301** and the cylinder **201** are active parts (wear parts) on which the pump's efficiency directly depends. It is therefore advisable to regularly check the pump's efficiency and replace the cylinder / piston if it decreases.

In addition, as using a cylinder / piston that is too worn may damage the pump's transmission system, it is advisable to replace the cylinder / piston if the maximum acceptable wear dimensions defined in the table below are reached.

		Piston 301 mm (inch)	Cylinder 201 mm (inch)
C12	New dimension	9 (0,354)	50 (1,969)
	Minimum wear dimension acceptable	6 (0,236)	47 (1,850)
C18	New dimension	9 (0,354)	70 (2,756)
	Minimum wear dimension acceptable	6 (0,236)	67 (2,638)

As changes in the pump's efficiency depend on the conditions of use (pressure, rotation speed, liquid pumped, etc.), MOUVEX recommends that users define the monitoring ranges and the preventive maintenance schedule according to their own experience.

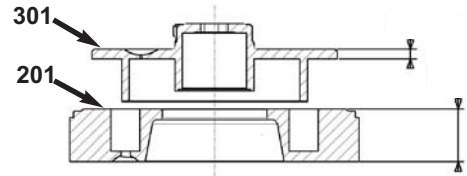

6. REASSEMBLY OF CYLINDER/PISTON

- Check the state of the seals **306**, **307** and **113**, replace them if necessary.
- Position the seals **113** and **307** on the main body and the seal **306** on the hub.

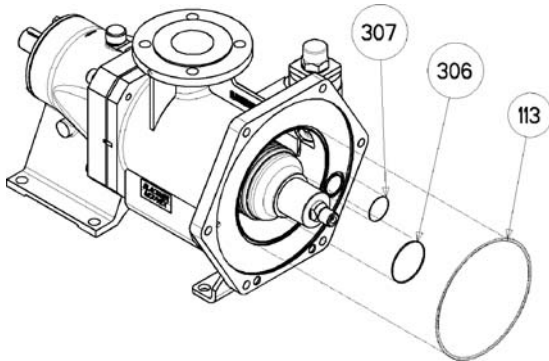

- Engage the piston **301** on the cylinder **201**, the gap of the piston facing the cylinder partition.
- Position the cylinder/piston unit **201/301** so that the recess of cylinder **201** faces positioning pin of the main body **101**.
- Engage the cylinder/piston unit **201/301** on transmission hub **596** (to make work easier, position transmission hub **596** upwards while turning the pump shaft). Then, push home making sure that the oblong hole of the piston engages within the 2 flat surfaces of the end of the transmission hub **596**.

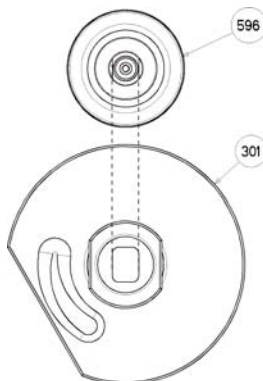
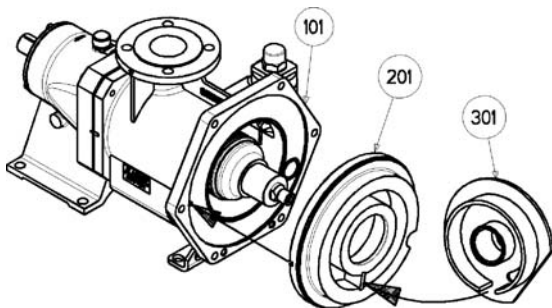

- Place thread locking adhesive (Loctite® 243* or equivalent) on the thread of the transmission hub **596**.

⚠ WARNING



BE CAREFUL WITH THE WEIGHT OF THE PARTS WHEN THEY ARE BEING REMOVED.

The weight of the parts can be dangerous and may provoke bodily injuries or material damages.

- Check the state of the seal **305**, replace it if necessary.
- Hold the piston **301** with a monkey wrench (opening 70 mm) and screw the nut **304** after first fitting the seal **305**.

It is important to keep a good grip on the piston, its rotation could lead to deterioration of the bellows. When tightening the nut, comply with the assembly torque of 200 Nm.

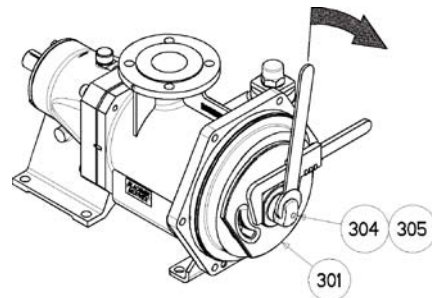

- Check the state of the seal **305** and replace it if necessary.
- Re-mount the front cover **401** while positioning the outlet port desired, with its seal **205**.
- Screw the 6 screws **106** (6 x M16 assembly torque 100 Nm).

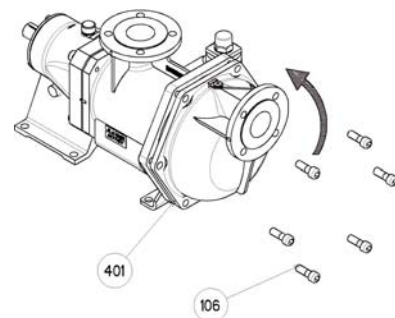
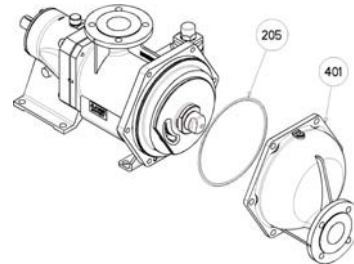

* Loctite® is a registered trademark.

7. PROTECTION OF THE BELLOWS



BE CAREFUL WITH THE WEIGHT OF THE PARTS WHEN THEY ARE BEING REMOVED.

- Dismantle the cylinder/piston couple (see corresponding §).
- Remove the 2 fixing screws from the base frame of the lug **108**.
- On the drive side, remove the 4 screws **111**.

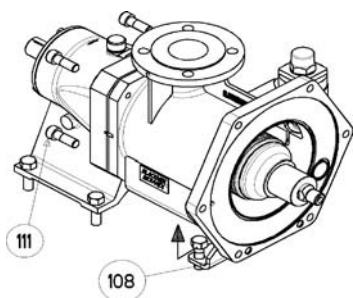

- With the help of a mallet, lightly tap the main body **101** to free it from the transmission **596**.
- Remove the tube **101** while taking care of impact.
- Remove the seal **113** (change it if necessary).
- Inspect the bellows : any impact, scratch or distortion necessitates its replacement.

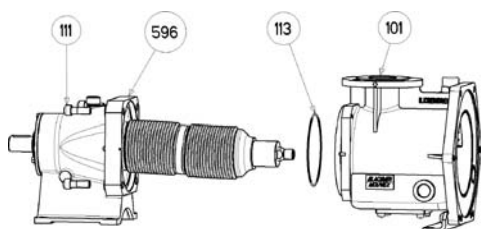

- Assembly is undertaken in the reverse order of dismantling, taking care to correctly position the seal **113** and main body **101**. The screws **111** must be re-mounted with thread locking adhesive (Loctite® 243* or equivalent) : 4 x M16 : Assembly torque 100 Nm.

Under preventive maintenance (every 150 millions of cycles duty), we suggest transmission replacement.

In this case : The transmission delivered is equipped with a tubular foam protection. We advise leaving this protection around the bellows until re-mounting of the piston and cylinder.



DO NOT FORGET TO REMOVE THE PROTECTION BEFORE MOUNTING THE CYLINDER.

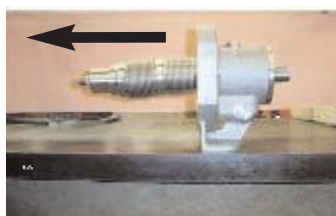

* Loctite® is a registered trademark.

8. CHANGING THE LIP SEALS



THE PUMP LUBRICANT IS VERY SLIPPERY AND MAY CAUSE SERIOUS INJURY. ANY SPILLS MUST BE CLEANED UP.

- Drain the pump bearing (see corresponding §).
- Remove the circlip **725**.
- Extract the 2 lip seals **608**.
- Check the gasket surface on the ring **507**.
- If the seal face is marked, change the ring **507**.
- Remove the seal **518**.
- Break the ring **507** with a chisel then fit a new ring after heating it at 95°C (in an oil bath or at HF).
- Place a new seal **518**.

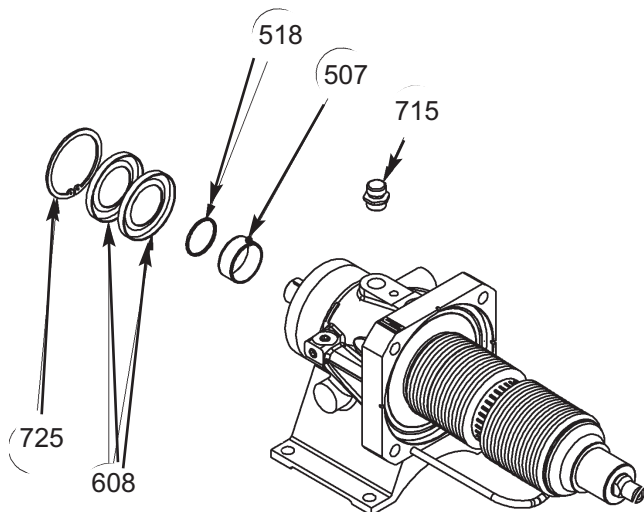

- Fit the 2 seals **608**, lip directed towards the interior of the transmission.
- Put grease between the 2 seals **608**.



FOOD SYNTHETIC GREASE :
Compulsory reference because compatible with the standard MOUVEX bearing oil.

- Replace the circlip **725**.
- After replacing the drain bung, fill the bearing with 4 litres of oil*. See § DRAINING OF BEARING.
- Screw back the breather **715**.

* Standard oil provided by MOUVEX : CS05 Food synthetic oil (Safety data sheet is supplied with the new pump and on inquiry).

* Other oil provided by customer.

9. CHANGING THE ORIENTATION OF THE DISCHARGE PORT



BE CAREFUL WITH THE WEIGHT OF THE PARTS WHEN THEY ARE BEING REMOVED.

- Unscrew the 6 screws **106**.
- Turn the front cover **401** so as to position the outlet port in the desired position.
- Replace the 6 screws **106** (6 x M16 : assembly torque 100 Nm).

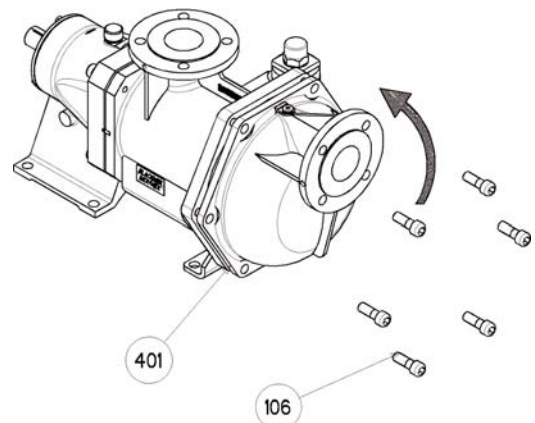

10. BYPASS

10.1 Bypass adjustment

- Remove the plug **833** as well as the seal **832**.
- Using a flat spanner, turn nut **834** clockwise to obtain a greater pressure (tightening of the spring) or counter-clockwise to obtain a lower pressure (loosening of the spring).
- Refit plug **833** and its seal **832**.

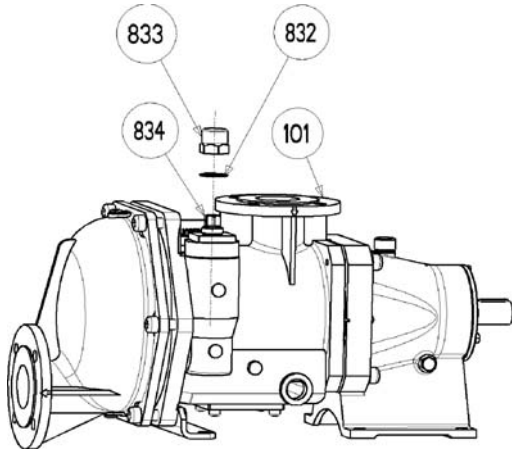

Spring	Adjustment range (bar)	C12	C18
C 2,5	0,9 à 2,5	X	X
C 5,5	2 à 5,5		X
C 6,5	2 à 6,5	X	
C 8	5 à 8	X	

10.2 Changing the spring

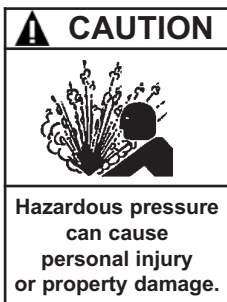

- Loosen the spring (see § BYPASS ADJUSTMENT).
- Loosen the pressure screw nut **828** of main body **101** taking care to the thrust produced by spring **804** (do not remove any associated parts).
- Remove the spring **804**.
- Replace spring **804** and carry out reassembly in reverse order of disassembly.

10.3 Replacement of the seals

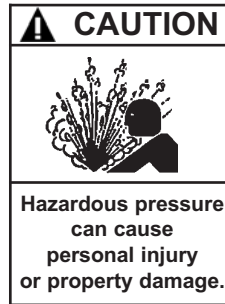

FAILURE TO RELIEVE SYSTEM PRESSURE PRIOR TO PERFORMING PUMP SERVICE OR MAINTENANCE CAN CAUSE PERSONAL INJURY OR PROPERTY DAMAGE.

- Loosen the spring (see § BYPASS ADJUSTMENT).
- Loosen the pressure screw nut **828** of main body **101** taking care to the thrust produced by spring **804**.
- Block the unit comprising the pressure screw nut **828** in a vice.
- Using a pin drift, remove pin **831**.
- Remove the nut **834**.
- Remove the screw **826**, the spring **829**, the seal **837** and the washer **838**.
- Replace seals and reinstall in reverse order of disassembly.

NOTICE :

When assembling seal **837**, we recommend covering the pin hole on shaft **826** with adhesive tape to avoid damaging the seal.

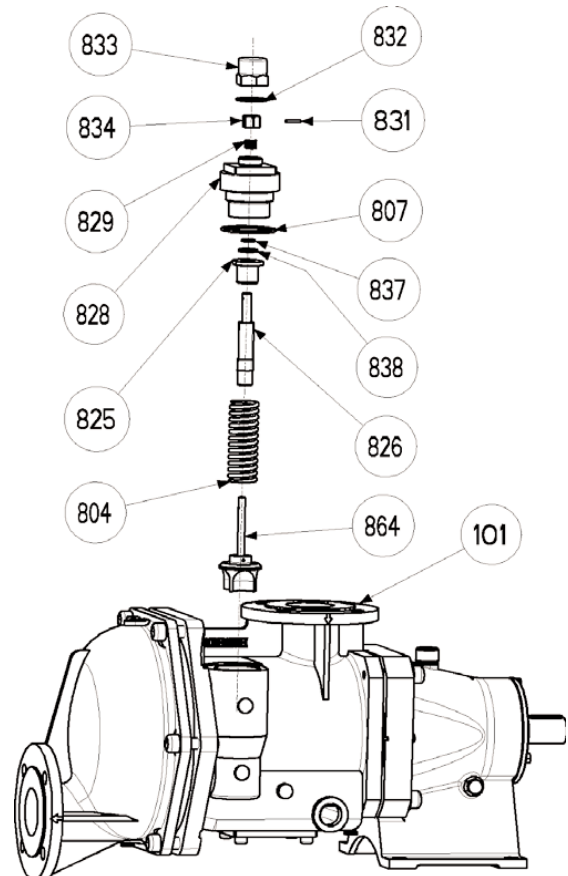

11. HEATING JACKET (option)

11.1 Replacement of the jacket seal

Before carrying out any work, make sure that no fluid flows in the casing (heating / cooling circuit valve closed) and that the pump is at ambient temperature.

⚠ WARNING



Hazardous pressure can cause personal injury or property damage.

DISCONNECTING THE FLUID OR PRESSURE CONTAINMENT COMPONENTS DURING PUMP OPERATION CAN CAUSE SERIOUS PERSONAL INJURY, DEATH OR MAJOR PROPERTY DAMAGE.

- Remove the 4 screws **132** from the main body **101** as well as the main body plate **131** and the seal **130**.
- Reassembly is in reverse order of disassembly.

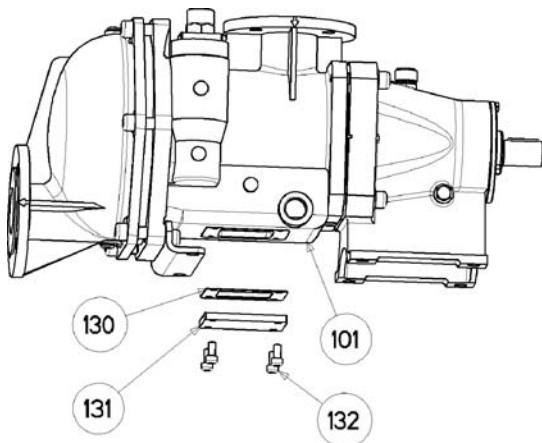

11.2 Bleed (included with jacket option)

- A bleed is provided on the main body **101** and the front cover **401** (only in position 2 or 4 for the front cover - see board "Possible positions" § INSTALLATION).
- Using an Allen key, unscrew the screws **122**.
- Check the state of the seal **121**, replace it if necessary.
- Reassembly is in reverse order of disassembly.

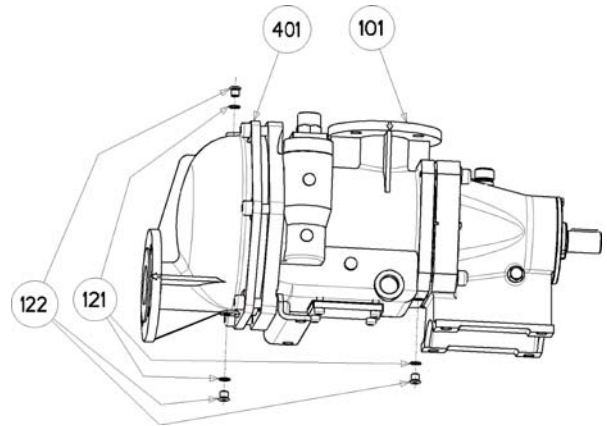

12. DRAINING OF BEARING

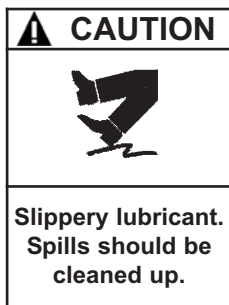

THE PUMP LUBRICANT IS VERY SLIPPERY AND MAY CAUSE SERIOUS INJURY. ANY SPILLS MUST BE CLEANED UP.

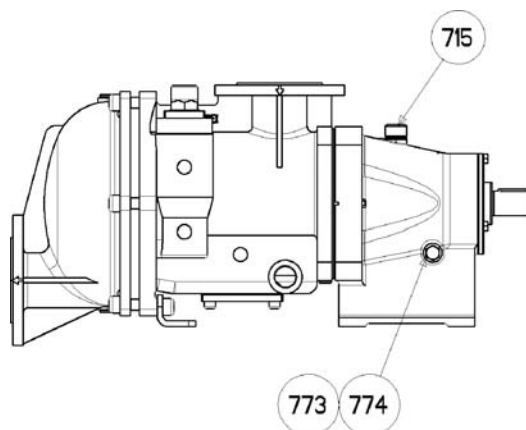

- Drain the transmission following the board below :

- **Data with standard MOUVEX oil :**

Temperature of product pumped / heating product	Draining interval (running hours)
150 °C < T ≤ 160 °C	800
135 °C < T ≤ 150 °C	1 500
120 °C < T ≤ 135 °C	3 000
100 °C < T ≤ 120 °C	6 000
80 °C < T ≤ 100 °C	12 000
T ≤ 80 °C	24 000

- **Data with other customer oil :** the drawing interval is defined by the customer (tests results) regarding the oil specifications and the pump conditions.

- Drain the pump by removing the drain bung with its seal **773-774** and the breather **715**.
- Replace the drain bung and its seal.
- Fill the transmission with 2 litres of oil*.
- Check oil level that the level is between 1 and 5 mm above the shaft.
- Screw back the breather **715**.

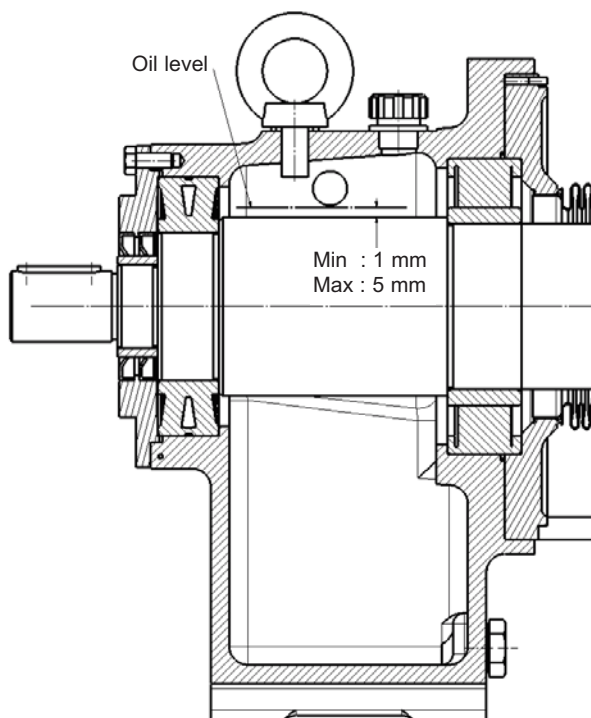

* Standard oil provided by MOUVEX : CS05 Food synthetic oil (Safety data sheet is supplied with the new pump and on inquiry).

* Other oil provided by customer.

13. OPTIONS

13.1 Liquid detector

The liquid detector works with single and double ply bellow. It is install on the vent circuit (see § PROTECTION OF THE PUMP INSTALLATION).

In case of flooded suction or during the cleaning process, a bellow puncture will fill the transmission with liquid. The liquid detector will inform the user when a bellow puncture occur.

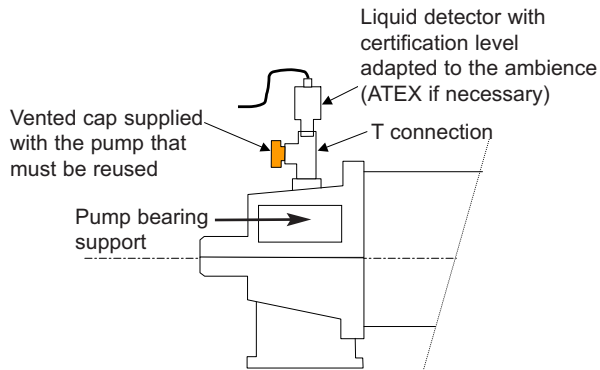

13.2 Bellow monitoring system

The bellow monitoring system called (BMS) works only with double ply bellow.

Working principle : During the transmission assembly, a gas pressure (argon) is introduced in between the bellow ply. A pressure switch is connected on the bellow's gas filling cavity and all the circuit is sealed. This operation is done by the factory and any technical operation will break the sealings (see picture) and avoid the warranty.

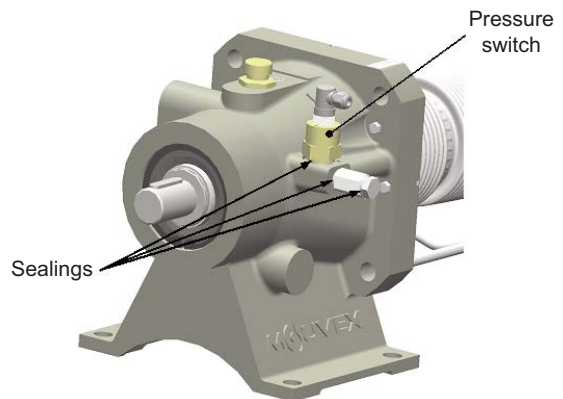

The gas pressure is 0,2 bar (2,9 psi) above the maximum acceptable pressure on the bellow under working condition.

Any puncture in either one of the two metallic bellows leads to a pressure drop. When the pressure decrease under the pressure switch setting, it cuts the electrical circuit.

To connect the electrical pressure switch, follow the manufacturer instruction.

14. CERTIFICATE OF CONFORMITY



CERTIFICATE OF CONFORMITY CE

Mouvex, ZI La Plaine des Isles – Rue des Caillottes – 89 000 Auxerre France, declares the following equipment:

Set-up : Pump / Compressor « bare-shaft » Pumping Unit / Compressor Unit
Type : Eccentric Disc Pump Vanes Pump Lobes Pump
 Peristaltic Pump Centrifugal Pump Other Pump
 Screws compressor Vanes compressors Hydraulic cooler

Designation: _____ s/n°: _____

According to the specifications recorded in the file N°: _____

And with the following marking:  IIB G c IIB-T4 Max T° Flow = 80°C

Is in conformity with the provisions of the following Directive:

- « **MACHINES** » Directive 2006/42/EEC as transposed by the national legislation, concerning safety equipments and arrangements relative to mechanical and electric risks applicable to rotative machines.

NF EN 809:2009 NF EN 1672-2:2009 NF EN ISO 13857:2008 NF EN 12162:2009

- « **ATEX** » Directive 94/9/EC (23 march 1994) as transposed by the national legislation, concerning equipment intended to be used in explosive atmospheres. Conformity obtained by application of the standards :

NF EN 1127-1:1997 NF EN 13463-1:2009 NF EN 13463-5:2009

ATEX Certification delivered by INERIS, Notified Body (INERIS - Parc Technologique Alata – 60550 Verneuil-en-Halatte - France).

The equipment indicated above must be used according to the foreseen use by its design and its manufacturing, and according to the current standards.

We, undersigned, declare that the concerned equipment is in conformity with the Directives listed above and in the applicable standards in force.

For Mouvex SAS Company.

Date: _____

Quality Manager

MOUVEX sas : Z.I La Plaine des Isles – 2, rue des Caillottes - 89000 AUXERRE – France – SAS au capital de 8 496 855 €
Tél : (33) 3.86.49.86.30 – Fax : (33) 3.86.46.42.10 – RCS AUXERRE 389 236 548 – APE 291 B – FR 85 389 236 548 – www.mouvex.com