



INSTRUCTIONS 1003-M00 e

Section	1003
Effective	September 2011
Replaces	October 2009

Original instructions

Bloddir mechanical seal AD - AF - AK - AL - AM - AR



Z.I. La Plaine des Isles - F 89000 AUXERRE - FRANCE
Tel. : +33 (0)3.86.49.86.30 - Fax : +33 (0)3.86.49.87.17
contact@mouvex.com - www.mouvex.com

Your distributor :

BLOCDIR MECHANICAL SEAL

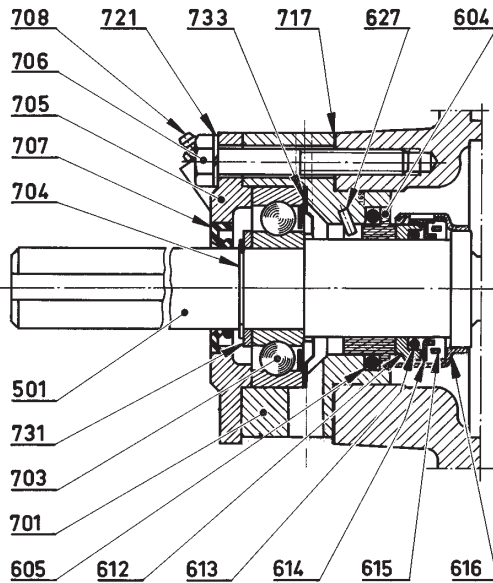

610 comprising : 604
605

697 comprising : 612
613
614
615
616

1. Operation

Shaft 501 drives the one piece rotating part 697 (including parts 612, 613, 614, 615 and 616) in a rotary motion. To do this, the rotating part is equipped with 2 lugs that fit into 2 grooves provided for this purpose on the shaft.

The stationary part 604 of the seal is fixed in the bearing cage 701 with an 'O' ring 605 and the stop pin 627.

Sealing is done :

- on the shaft by the 'O' ring in the rotating seal part 613,
- by the surfaces in contact between the rotating part 697 and the static matching part 604,
- in the bore of the bearing cage 701 by the 'O' ring 605 tightened between the bearing cage and the fixed matching part 604.

Sealing is therefore done as a function of the condition of these contact surfaces and the seals.

2. Dismantling

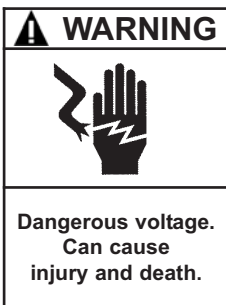

DISCONNECT THE ELECTRICITY SUPPLY BEFORE ANY MAINTENANCE OPERATION.



FAILURE TO RELIEVE SYSTEM PRESSURE PRIOR TO PERFORMING PUMP SERVICE OR MAINTENANCE CAN CAUSE PERSONAL INJURY OR PROPERTY DAMAGE.

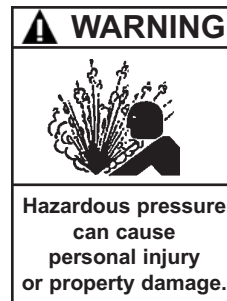

DISCONNECTING THE FLUID OR PRESSURE CONTAINMENT COMPONENTS DURING PUMP OPERATION CAN CAUSE SERIOUS PERSONAL INJURY, DEATH OR MAJOR PROPERTY DAMAGE.

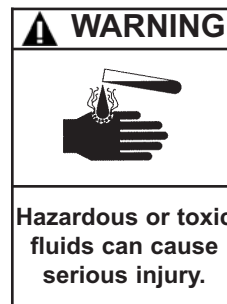

IF PUMPING HAZARDOUS OR TOXIC FLUIDS, THE SYSTEM MUST BE FLUSHED PRIOR TO PERFORMING ANY SERVICE OPERATION.

Before opening the pump, you must always drain it and release the pressure it may contain. Make sure that the isolation valves, if any, are closed or drain the installation before pulling out the drain plug 434 (812 for AD) and its seal 412 (848 for AD).

BLOCDIR MECHANICAL SEAL (continued)

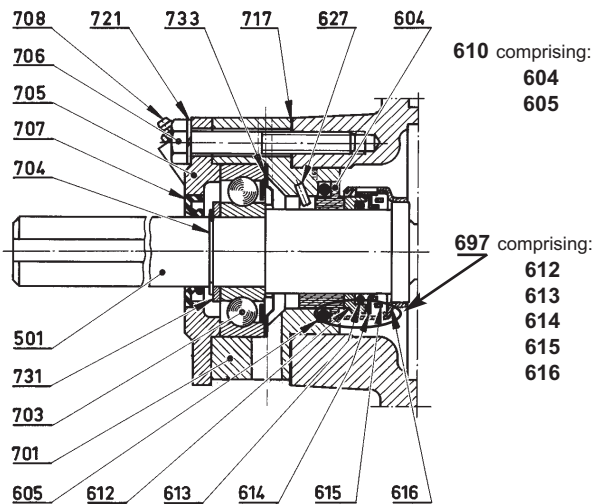

After opening the pump (see § 4.*):

To remove a taper lock shaft coupling

1. Dismantle the coupling of the pump.
For the standard coupling supplied by MOUVEX, loosen the hexagonal socket head screws, and by replacing one of them in the slot provided for this purpose to release the tapered lock bushing.
For any other coupling, please refer to the supplier's instructions.
2. Remove the shaft key **508**.

To remove the bearing cover 705

1. Unscrew the screws **706** and washers **721**.
2. Remove the bearing cover **705**.
3. Check the condition of the lip seal **707**.

To dismantle the front cover 401 of the pump (please consider also to § 4.1*)

1. Loosen the bolts **409** and nuts **409a**.
2. Remove the front cover **401**.
3. Remove the seal **403** and check its condition.
If the front cover does not easily separate, tap it lightly with a plastic mallet to separate it progressively.
4. Extract the piston **301** (please also consider § 4.2*).

To dismantle the bearing 703

1. Remove the circlip **704** using circlip pliers or a screwdriver, taking care not to damage it.
2. Remove the washer **731**.
3. Remove the shaft **501** from the bearing **703** by tapping it lightly with the plastic mallet on the drive side of the pump. Hold the shaft **501** firmly during dismantling.
4. Remove the protection circlip **733**.

To dismantle the bearing cage 701

1. Separate the bearing cage **701** by tapping it with a plastic mallet.
2. Remove the bearing cage seal **717** and check its condition.

To dismantle the complete stationary part 610 of the mechanical seal

1. Remove the stationary part of the mechanical seal **604**
2. Remove the 'O' ring **605** from the holder and check its condition.

To dismantle the rotating part 697

1. Remove the rotating part **697** from the shaft **501**, taking care not to scratch it (especially in the case of FEP encapsulated 'O' rings. Check the condition of shaft surface, rub it down with emery paper No 320 if scratched).

3. Assembly

Assembly of the rotating part 697

1. Mount the rotating part **697** on the shaft **501** (with the assembly cone for the FEP 'O' rings) taking care not to scratch the shaft (extremely important in the case of the assembly of FEP 'O' rings. Check the condition of the shaft surface, rub it down with emery paper No320 if scratched). Align the 2 lugs of the rotating part **697** with the 2 grooves on the shaft **501**.
2. Clean the seal surface on the rotating part with a soft cloth if it is dirty. Be careful not to scratch the surface of the seal.

To assemble the complete stationary part 610 of the mechanical seal

1. Clean the 'O' ring groove in the bearing cage **701**.
2. Locate the 'O' ring **605** in the bearing cage **701**.
3. Place the stationary part of the seal **604** in the bearing cage **701**, taking care to align the pin located in the rolling bearing cage **701** with the groove on the stationary part of the seal **604**.
4. Clean the surface of the seal with a soft cloth if it is dirty. Be careful not to scratch the surface of the seal.

Assembly of bearing 703

1. Place the protection washer **733** in the bearing cage **701**.
2. Position the shaft **501** with the rotating part **697** in the bearing cage **701** with the washer **733**.
Be careful not to knock the 2 surfaces of the seals.
3. Position the bearing **703** on the end of the shaft **501**. Tap the shaft lightly with a plastic mallet (NOT THE PUMP DRIVE END).
4. Place the shaft **501** drive end up in a vice, resting on the bearing cage **701**, and tap on the inside of the bearing **703** with the tube (the tube will have an internal diameter slightly larger than the internal diameter of the ball bearing) and the plastic mallet until you see the circlip groove **704** on the shaft. Be careful not to damage the seal (tap lightly on the tube).
5. Assemble the washer **731** and the circlip **704** on the shaft **501**.

NOTICE : We recommend the use of a hand press.

Remounting the piston 301

Assembly of front cover 401

1. Clean the seal housing **403** and mount the seal **403**.
2. Replace the front cover **401**, taking care that the piston guide block is well assembled in its housing taking care not to damage the seal **403**.
3. Tighten the bolts **409** with the nuts **409a**.

To assemble the rolling bearing cage 701

1. Clean the cage seal **717**.
2. Assemble the cage seal **717** on the bearing cage **701**.
3. Position the shaft **501** in the pump.
4. Fill the bearing **703** with grease (see § MAINTENANCE).
5. Reassemble the cover **705**, grease the lip of the lip seal **707** to ease assembly.
6. Replace the screws **706** and their washers **721**.

* of the pump's Instructions.

BLOCDIR MECHANICAL SEAL (continued)

4. Maintenance

Except for special cases, the MOUVEX pump only requires lubrication of the shaft inlet bearing.

Use a grease for good quality ball bearings.

Lubrication must be done every 1,000 hours of operation or at least once a year.

The quantity of grease to be added must not exceed :

- AD pump7 cm³
- AF pump8,5 cm³
- AK pump17 cm³
- AL pump20 cm³
- AM pump20 cm³
- AR pump30 cm³

For pumps operating at high temperatures (in principle from 100°C upwards) use a grease with a high drop point.

Preference should be given to lubricants insoluble in the product pumped and, in the case of hot products, lubricants that maintain good viscosity at the operating temperature.

5. Spare parts

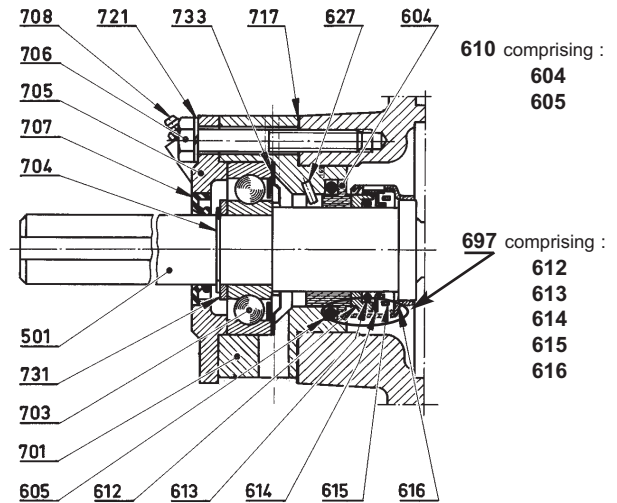

Reference			Description	Quantity	
Ass.	Part	Available		Order	In Pump
600		◆	Mechanical seal - Blokdir	1	
		610	Stationary seal face complete - Blokdir		(1)
		604	Stationary seal face		(1)
		605	Seal		(1)
		619	Seal mounting tool (for CVT)		(1)
		697	Rotating part - Blokdir		(1)
		612	Seal housing		(1)
		613	Seal		(1)
		614	Spring guide		(1)
		615	Spring		(1)
	616	Cage		(1)	
700		◆	Ball bearings complete	1	
		▲	Pin	1	
			Bearing cage		(1)
		▲	Ball bearing	1	
			Bearing cover		(1)
			Screw (Qty = AD : 3 - AM and AR : 6)		(4)
			Grease nipple		(1)
			Washer (Qty = AD : 3 - AM and AR : 6)		(4)
		◆	Ball bearing washers and gasket set	1	
			Ring		(1)
			Lip seal		(1)
			Cage seal		(1)
			Washer (Qty = AF : 2)		(1)
			Protection circlip		(1)

(◆) Sets of parts or (▲) parts available to order.