

# ***BLK4-T***

## ***Transport lobe pump***



**INSTALLATION**

**OPERATION**

**MAINTENANCE**

# 1 Table of contents

<b>1</b>	<b>Table of contents</b> .....	<b>2</b>
<b>2</b>	<b>Safety</b> .....	<b>3</b>
2.1	Instruction Manual annex .....	3
2.2	Start-up instructions .....	3
2.3	Safety.....	3
2.4	Generally safety instructions .....	3
<b>3</b>	<b>General Information</b> .....	<b>5</b>
3.1	Description .....	5
3.2	Operating Principle .....	5
3.3	Application.....	5
<b>4</b>	<b>Installation</b> .....	<b>6</b>
4.1	Pump reception.....	6
4.2	Transport and storage .....	6
4.3	Location .....	7
4.4	Coupling (for external shaft model) .....	7
4.5	Pipes .....	8
4.6	Secondary piping.....	9
4.7	Relief valve.....	9
4.8	Electrical installation .....	10
<b>5</b>	<b>Start-up</b> .....	<b>11</b>
5.1	Start-up.....	11
5.2	Pressure Relief valve .....	12
<b>6</b>	<b>Operating Problems</b> .....	<b>13</b>
<b>7</b>	<b>Maintenance</b> .....	<b>14</b>
7.1	General maintenance.....	14
7.2	Storage .....	14
7.3	Cleaning .....	15
7.4	Pump disassembly.....	16
7.5	Pump assembly .....	18
7.6	Lobe adjustment .....	20
<b>8</b>	<b>Technical Specifications</b> .....	<b>22</b>
8.1	Technical specifications .....	22
8.2	Weight .....	23
8.3	BLK4-T Pump dimensions .....	24
8.4	BLK4-T Exploded view .....	26
8.5	Scrapping .....	28
<b>9</b>	<b>Certificate of conformity</b> .....	<b>29</b>

# 2 Safety

## 2.1 INSTRUCTION MANUAL ANNEX

This instructions manual annex contains information regarding the reception, installation, operation, assembly, adjustment, disassembly, and maintenance of a BLK4-T pump.

The information provided in this manual is based on the most recent available data. MOUVEX reserves the right to modify this instruction manual without prior notice.

## 2.2 START-UP INSTRUCTIONS

This instructions manual annex contains essential and useful information for starting up the pump properly and for keeping it in good operating condition.

Before starting up the pump, it is necessary for the people concerned to carefully read the safety instructions in this chapter and familiarise themselves with the pump's operating characteristics. They must also strictly follow the provided instructions. It is extremely important that the instructions always be kept in the same place near the installation.

## 2.3 SAFETY

### 2.3.1 Warning signs



Danger for people in general.



Danger of injury caused by rotating parts of the equipment.



Danger! Electricity.



Danger! Caustic or corrosive agents.



Danger! Suspended loads.



Danger to the proper operating of the machine.



Obligation to ensure safety at work.



Use of safety goggles obligatory.

## 2.4 GENERAL SAFETY INSTRUCTIONS



Please read this Instructions Manual annex carefully before installing and starting up the pump. Contact MOUVEX if you have any doubts or queries.

### 2.4.1 During installation

It is necessary to take into account the *Technical Specifications* set forth in Chapter 8.



Do not put the pump into operation before connecting it to the pipes.

Do not put the pump into operation if the rotor case of the pump has not been fitted and the lobe rotors fixed in the pump.

Check that the drive specifications are suitable, particularly if there is a serious risk of explosion derived from the working conditions.



During the installation procedure, all the electrical work must be carried out by duly authorised personnel.

### 2.4.2 During operation

It is necessary to take into account the *Technical Specifications* set forth in Chapter 8. The specified limit values must NEVER be exceeded.



NEVER touch the pump or pipes whenever the pump is being used to transfer hot liquids or during the cleaning procedure.



The pump has moving parts. Never place your fingers inside the pump while the pump is operating.



**NEVER** work with the suction and discharge valves shut off.

**NEVER** directly sprinkle the electric motor with water. Standard motor protection is IP-55: dust and water sprinkling protection.

#### 2.4.3 During maintenance



It is necessary to take into account the *Technical Specifications* set forth in chapter 8.

**NEVER** disassemble the pump until the pipes have been drained. Remember that some of the liquid will always remain in the rotor case (if it has not been fitted with a drain). Always remember that the liquid that has been pumped may be dangerous or subject to high temperatures. In situations of this type, always consult the prevailing regulations in the country in question.

Do not leave loose parts on the floor.



**ALWAYS** shut off the power supply to the pump before starting maintenance work. Remove the fuses and disconnect the wires from the motor terminals.

All electrical work should be carried out by duly authorised personnel.

#### 2.4.4 In compliance with the instructions

Non-compliance with any of the instructions could represent a danger to the operators, the atmospheric conditions of the room, and to the machine; it may also lead to loss of any right to claim for damages. Such non-compliance could bring with it the following risks:

- Significant faults in operation of the machine/plant.
- Non-compliance with the specific maintenance and repair procedures.
- Possibility of electrical, mechanical and chemical risks.
- The atmospheric conditions in the room may be hazardous due to the release of chemical substances.

#### 2.4.5 Warranty

We wish to point out that any warranty issued will be null and void and that we are entitled to an indemnity for any civil liability claim for products which might be filed by third parties if:

- Operation and maintenance work has not been done following the corresponding instructions; the repairs have not been made by our personnel or have been made without our written authorization;
- Modifications are made to our material without prior written authorization;
- The parts or lubricants used are not original MOUVEX parts/lubricants;
- The material has been improperly used due to error or negligence or has not been used according to the indications and the intended purpose.
- The parts of the pump have been damaged as a result of having been exposed to strong pressure as there was no pressure relief valve.

The General Terms and Conditions of Discharge supplied to you shall also apply.



**No modifications may be made to the machine without the prior consent of the manufacturer. For your safety, please use original spare parts and accessories. The use of other parts will exempt the manufacturer from any liability.**

Any changes to the operating conditions may only be made with the written consent of MOUVEX in writing.

Please contact us if you have any doubts or require further explanation regarding specific data (e.g. adjustment, assembly, and disassembly).

# 3 General Information

## 3.1 DESCRIPTION

The MOVEX BLK4-T lobe pumps form part of our wide range of positive displacement rotary pumps for viscous liquids. The lobe pump range covers the following models:

- BLK4-T pump suitable for differential pressure of up to 7 bar.

The BLK4-T model is especially developed to meet all hygiene needs in food industry.

As regards hygiene, reliability and sturdiness, the complete range of rotary lobe pumps satisfies all requirements set by the aforesaid industries.

The rotary lobe pumps are positive displacement pumps. Owing to the contact between the internal parts, the pressure variations, etc. they make a louder noise than centrifugal pumps. This noise must be taken into consideration when installing these pumps.

## 3.2 OPERATING PRINCIPLE

The rotary lobe pump is a positive displacement rotary pump. The top lobe is operated by the drive shaft. The bottom lobe is located on the driven shaft, and is operated by means of helical gear. Both lobes turn in synchronisation without touching each other. During pump operation, a fixed volume is displaced. The following illustrations show how the lobe pump operates.

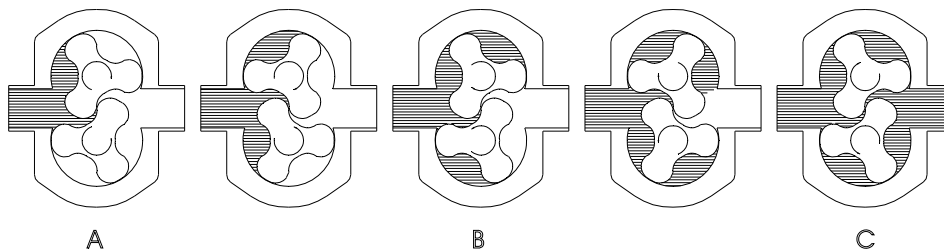

**A:** When the lobes rotate, the space on the suction side increases because one lobe moves away from the other, thus causing a partial vacuum that draws the liquid into the pumping chamber.

**B:** Each lobe void is filled consecutively as the shafts rotate and the liquid is displaced towards the discharge side. The small clearances between the lobes, and between the lobes and the walls of the rotor case, duly cause the spaces to be rather well closed.

**C:** The rotor case is completely full and the liquid leaks through the meshing of the lobes, knocking against the space walls so as to thus complete the pumping action.

## 3.3 APPLICATION

The main advantage of the MOVEX BLK4-T lobe rotor pump is its capacity to pump a wide range of viscous liquids, from 1mPa.s to 100,000 mPa.s.

Furthermore, it can pump delicate liquid products and/or products containing soft solids, which require rather careful handling with as little degradation as possible.



**The range of application of each pump is limited. The pump was selected for a given set of pumping conditions when the order was placed. MOVEX shall not be liable for any damage resulting from incompleteness of the information provided by the purchaser (nature of the liquid, RPM, etc.).**

# 4 Installation

## 4.1 PUMP RECEPTION



**MOUVEX is not responsible for any deterioration of the material as a result of its transportation or unpacking. Visually check that the packing has not suffered any damage.**

The pump will be accompanied by the following documentation:

- Dispatch notes.
- Pump Instruction and Service Manual.
- Drive Instruction and Service Manual (\*).

(\*): If the pump has been supplied with a drive from MOUVEX.

Unpack the pump and check the following:

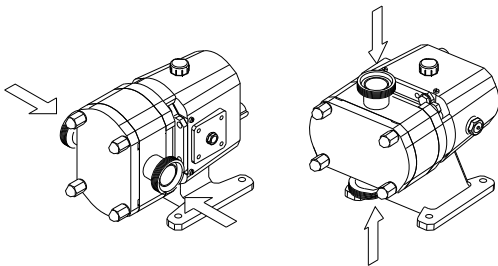

- The pump suction and delivery connections, removing the remains of any packing material.
- Check that the pump and the motor have not suffered any damage.
- Should the pump not be in proper condition and/or does not have all the parts, the haulier must draw up a report as soon as possible with regard to the same.

### 4.1.1 Pump identification and marking

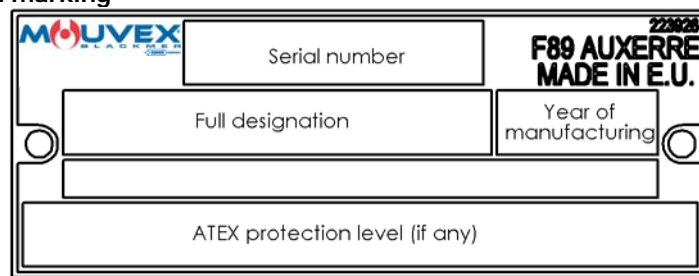

Pump plate

## 4.2 TRANSPORT AND STORAGE



**BLK pumps and pumping units are often too heavy to be handled manually. Use an adequate means of transport.**

**Use the points which are indicated in the drawing for lifting the pump.**

**Only authorized personnel should transport the pump.**

**Do not work or walk under heavy loads.**

Lift the pump as shown below:

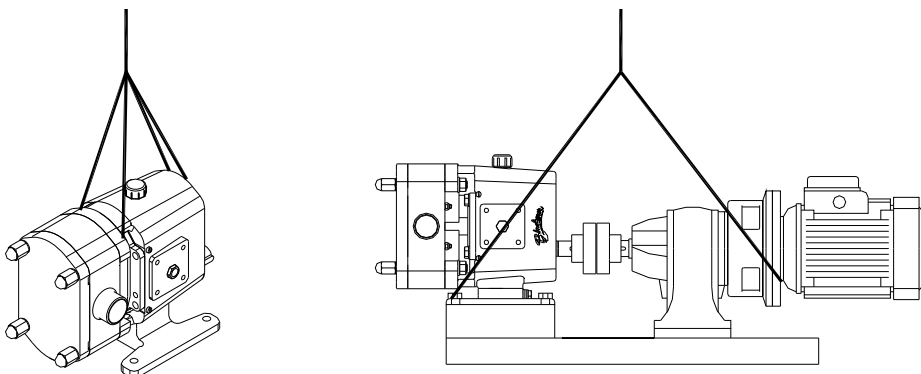

- Always use two support points placed as far apart as possible.
- Secure the supports so that they will not move.
- See chapter **8**. **Technical Specifications** to consult dimensions and weights.

### 4.3 LOCATION

- Position the pump as near as possible to the suction tank, and whenever possible below the level of the liquid.
- Place the pump in such a way that there is enough space around it to provide access both to the same and to the motor. (See Chapter 8. *Technical Specifications* to consult dimensions and weights).
- Place the pump on a level and flat surface.



**Install the pump in such a way that it can be properly ventilated. If the pump is to be installed outside, it must be done so under cover. Its positioning must enable easy access for any inspection and maintenance operations that may need to be carried out.**

#### 4.3.1 Foundation (for stationary unit)

Install the pump base so that the drive and pump are level and well supported. Therefore the pump unit should be installed on a base plate –according to DIN 24259–, or on a frame, both placed exactly level on the foundation. The foundation must be hard, level, flat, and vibration free ...to prevent base distortion (to keep the alignment pump –drive guaranteed while commissioning).

To install the pump unit on the foundation proceed as follows:

- Make holes in the foundation to fit foundation bolts. This is unnecessary when expanding screws are used instead of foundation bolts.
- Place base plate or frame with the aid of shims horizontally on the foundation.
- Grout
- When the grout has entirely hardened the pump unit can be placed on the baseplate or the frame. Tighten the nuts on the foundation bolts carefully.

For other foundations consult MOUVEX.

### 4.4 COUPLING (for external shaft model)

For the couplings selection and assembly consult to the supplier manual. Sometimes the torque of the positive displacement pumps can be high enough. Therefore, a coupling have been chosen 1.5 to 2 the adequate torque.

#### 4.4.1 Alignment

The pump and motor shaft of complete units have been accurately pre-aligned in our factory.



**After installations of the pump unit, the pump and motor shaft should be re-aligned.**

- After unit is installed recheck alignment of pump and motor shaft and alignment of piping. Realign if necessary.
- In the case of applications dealing with high temperatures the pump can be operated temporarily at its working temperature. Then recheck alignment pump - piping.

Place a straight-edge (A) on top of the coupling: the straight should make contact with both halves of the coupling over their entire length. See figure.

Repeat the check, but this time on both sides of the coupling near the shaft. For the sake of accuracy, this check should also be done using an outside caliper (B) at two diametrically opposite points on the outside surfaces of the two halves of the coupling.

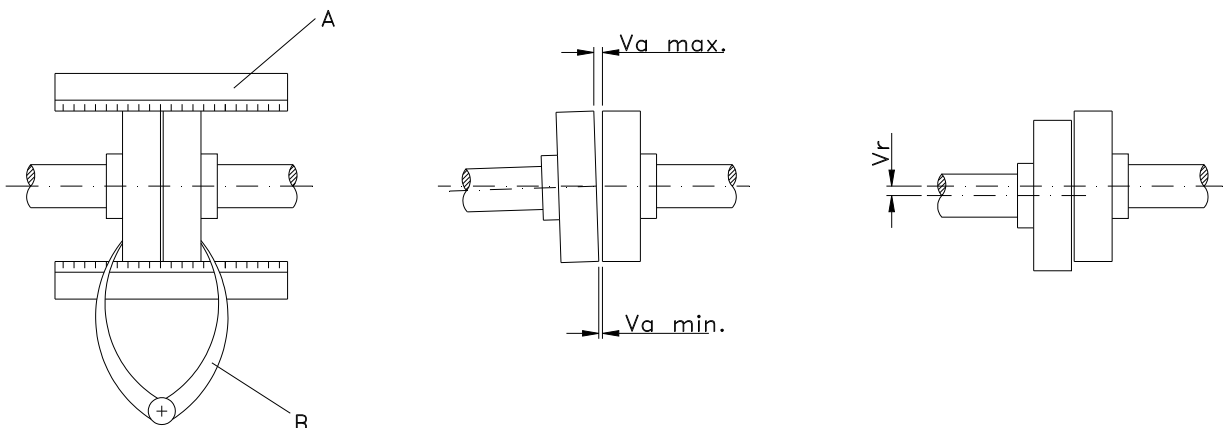

## Maximum alignment deviations:

Outside diameter of the coupling [mm]	Va min. [mm]	Va max. [mm]	Va max. - Va min. [mm]	Vr max. [mm]
70 - 80	2	4	0,13	0,13
81 - 95	2	4	0,15	0,15
96 - 110	2	4	0,18	0,18
111 - 130	2	4	0,21	0,21
131 - 140	2	4	0,24	0,24
141 - 160	2	6	0,27	0,27
161 - 180	2	6	0,3	0,3
181 - 200	2	6	0,34	0,34
201 - 225	2	6	0,38	0,38

## 4.5 PIPES

- In general, suction and delivery pipes should be fitted in straight stretches, with the minimum amount of elbows and accessories, in order to reduce, as far as possible, any head loss that might be produced by friction.
- Make sure that the pump ports are well aligned with respect to the piping and that they are similar in diameter to that of the pipe connections.
- Position the pump as near as possible to the suction tank, and whenever possible below the level of the liquid, or even lower with respect to the tank in order for the static suction head to be at its maximum.
- Place brackets for the piping as near as possible to the suction and delivery ports of the pump.

### 4.5.1 Shut-off valves

The pump can be isolated for the purpose of carrying out maintenance work. To this end, shut-off valves should be fitted at the pump's suction and delivery connections.



**These valves must ALWAYS be open whenever the pump is operating.**

### 4.5.2 Self-priming process

In general terms --if the self-priming process is followed-- the pump ought to contain sufficient liquid to fill the internal recesses and the void spaces thus enabling the pump to create a pressure difference.

However, if low viscosity fluids are to be pumped, a foot valve of the same or greater diameter as that of the suction pipe should be installed; alternatively, the pump can be installed with a "U" shaped piping.



**The use of a foot valve is not recommended for pumping viscous liquids.**

In order to eliminate air and gases from the suction pipe, the counter-pressure on the discharge pipe should be reduced. When the self-priming process is used, the pump's start-up should be done by opening and emptying the discharge pipe which allows the air and gases to escape at a low counter-pressure.

Another possibility involves long pipes or when a check valve is installed in the discharge pipe; it is also possible to install a relief valve with a shut-off valve on the discharge side of the pump. This valve shall be opened in the case of priming and will allow air and gases to escape at a minimum counter-pressure.

The relief valve should not lead back to the intake orifice but to the supply tank instead.

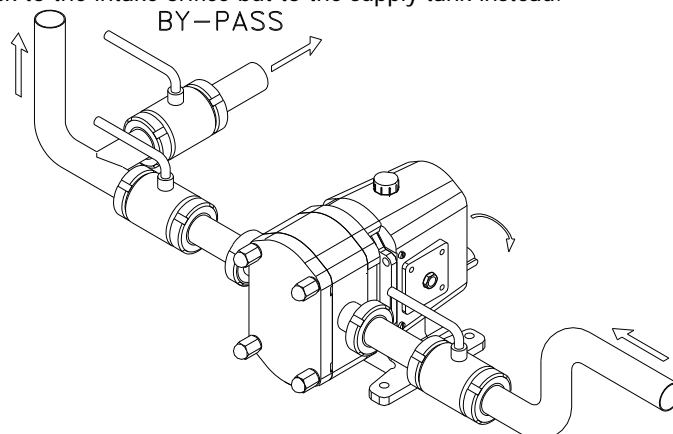

## 4.6 SECONDARY PIPING

### 4.6.1 Heating / cooling jackets

Heating / cooling jackets (S) are available on the front cover or/and around the seal. Heating or cooling media can be provided via connections according to next figure.

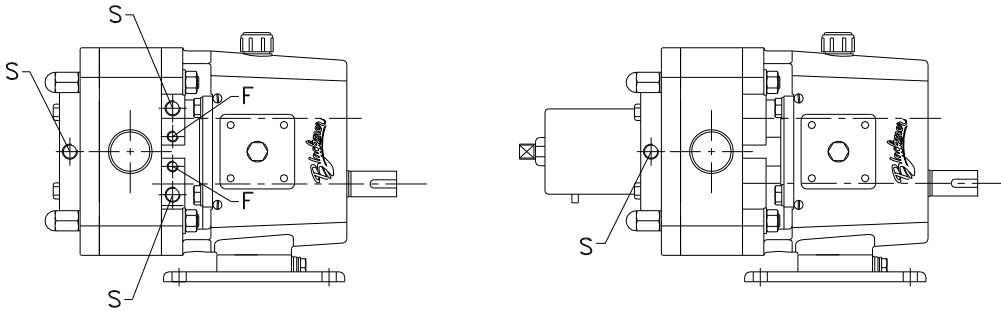

## 4.7 RELIEF VALVE



**The positive displacement lobe pumps must be protected from excess pressure when they are operating. Consequently, all the BLK pumps can be fitted with a stainless steel relief valve or a pressure relief valve**

### 4.7.1 Protection

This valve protects the pump and prevents excessively high pressure arising in the circuit. It reduces the differential pressure ( $\Delta p$ ) between suction and discharge, but not the maximum pressure within the plant.



**Do not use the relief valve to protect the system from excess pressure. It is designed to protect the pump only as it is not a safety outlet.**

### 4.7.2 Operation principle

The pressure relief valve is located in the rotor case and prevents excess pressure arising inside the pump. For example, when the pump's discharge port is clogged and the liquid cannot be pumped out, too high a pressure can cause serious damage to some of the pump's parts. The relief valve opens a passage from the pump's discharge side to its suction side: an escape route, redirecting the flow again to the suction side whenever specifically high pressure levels are reached. The relief valve is effective in both directions of rotation.



**If the relief valve operates, this will mean that the equipment is not working properly. The pump should be disconnected immediately. Identify and solve the problem before re-starting the pump.**



**Remember that the relief valve in the pump is not able to be used to regulate the flow rate. If the relief valve is not fitted in the pump, other steps should be taken to protect the pump from excess pressure.**

The relief valve can be adjusted to any determined pressure, according to the type of pump being used.

## 4.8 ELECTRICAL INSTALLATION



Leave the connecting of the electrical motors to qualified personnel. Take the necessary measures to prevent any breakdowns in the connections and wires.



The electrical equipment, the terminals and the components of the control systems may still carry an electric charge even when disconnected. Contact with them may put the safety of operators at risk, or cause irreparable damage to the material.

**Before maneuvering the pump, make sure that the electric box is switched off.**

- Connect the motor in accordance with the instructions supplied by the manufacturer of the same.
- Check the direction of the rotation (see the signaling label on the pump).

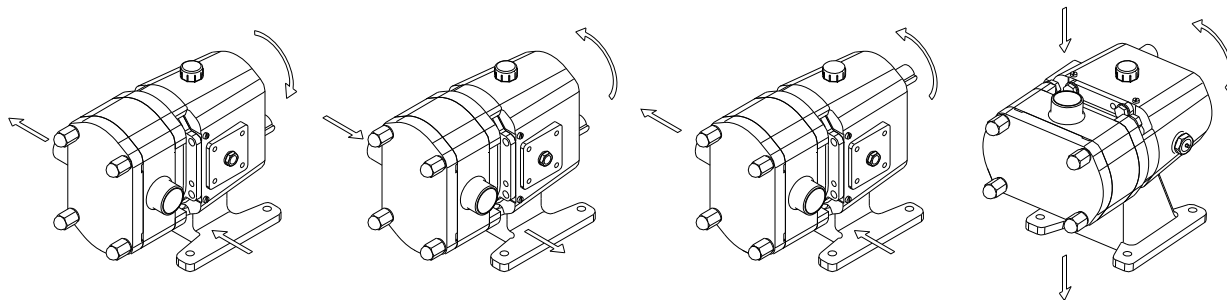

- Start the pump motor briefly. Make sure the pumping direction is the right one. If the pump operates in the wrong direction it may cause severe damage.



**Check ALWAYS the direction of the motor's rotation with liquid inside the pump.**

# 5 Start-up



Before putting the pump into operation read carefully the instructions on installation given in Chapter 4. *Installation*.

## 5.1 START-UP



Read Chapter 8. *Technical Specifications* carefully. MOUVEX will not assume responsibility for any improper or incorrect use of the equipment.



Do not touch the pump or the piping while it is pumping products at a high temperature.

### 5.1.1 Checks to be carried out before putting the pump into operation

- Completely open the pipes' suction and delivery shut-off valves.
- Take care to mount the breather on the transmission, instead of the sealing plug used during the transport.
- Check oil level of the pump. Add correct grade of oil as necessary to maintain level in center of oil sight glass (in case of first start-up: even if pumps are shipped with the right oil quantity, always check the oil level before start).
- If the liquid fails to flow toward the pump, fill it with the liquid to be pumped.



The pump must NEVER rotate without fluid inside it.

- Check that the power supply matches the rating indicated on the motor plate.
- Check that the direction of rotation of motor is the right one.

### 5.1.2 Checks to be carried out on putting the pump into operation

- Check to make sure that the pump is not making any strange noises.
- Check to see if the absolute inlet pressure is sufficient, in order to avoid cavitations in the pump. Consult the curve for the minimum required pressure above the steam pressure (NPSHr).
- Monitor the delivery pressure.
- Check that there are no leaks in the sealed areas.



A shut-off valve should not be used in the suction pipe to regulate the flow rate. It must be completely open during operation.



Monitor motor consumption in order to avoid a circuit overload.

Reduce flow and motor power consumption by reducing motor speed.

The operator should remain nearby the equipment through-out the use to ensure the proper functioning of the system.

## 5.2 PRESSURE RELIEF VALVE

The valve's opening pressure depends on the fluid to be pumped, its viscosity, its rpm ..., and so before starting-up the pump, the operator ought to adjust the relief valve's opening pressure.

### 5.2.1 Front Cover Assembly

When the relief valve is equipped this valve has been adjusted to the pump's maximum operating pressure. The operator must check this by observing the position of the pin (55D). When the pin is completely displaced to the pump cover, valve has been set at the pump's maximum pressure.

To obtain the correct opening pressure, the following procedure should be followed:

- Loosen the nut (54C).
- Using a spanner, turn the adjusting screw (25A) to the right to reduce the spring tension, and thus obtain the required opening pressure. When making this operation, observe that the pin's position (55D) backs up to position of the pump cover.
- If the correct opening pressure has been obtained, tighten the nut (54C).



**When checking the relief valve also make sure the pump's pressure will NEVER exceed the pressure setting + 2 bar.**



**When the relief valve does not work properly, the pump must be taken out of service immediately. The valve must be inspected by a MOUVEX service technician.**

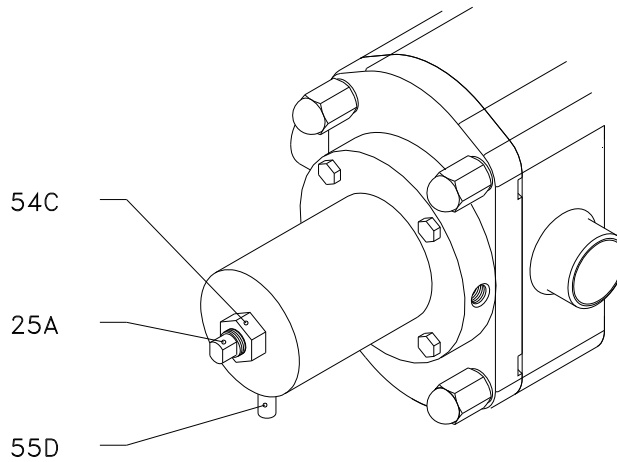

Springs types that can fit in function of the pressure setting : **2-7 bar**

# 6 Operating Problems

The table given below provides solutions to problems that might arise during pump operation. With respect to the same, it is assumed that the pump has been properly installed and has been correctly selected for the application in question. Should there be a need for technical service please contact MOUVEX.

Operating problems	Probable causes
Motor overload.	8, 9, 12, 16, 20, 21, 22, 23, 24, 26.
Insufficient discharge flow rate.	2, 4, 5, 7, 8, 9, 10, 11, 13, 14.
No pressure on the discharge side.	1, 2, 3, 6, 7.
Irregular discharge flow rate/pressure.	2, 4, 5, 6, 9, 12.
Noise and vibrations.	2, 4, 5, 6, 7, 8, 9, 11, 12, 13, 16, 19, 20, 21, 22, 23, 24, 25, 26.
The pump gets clogged.	8, 9, 11, 16, 19, 20, 21, 22, 24, 25, 26.
Overheating of pump.	7, 8, 9, 11, 12, 16, 20, 21, 22, 23, 24, 26.
Abnormal wear.	4, 5, 11, 15, 16, 19, 24, 25.
Leak.	17, 18, 27.

Probable causes	Solutions
1 Wrong rotation direction.	Invert the rotation direction.
2 Insufficient NPSH.	Increase available NPSH : - Rise the suction tank - Lower the pump - Reduce the speed - Increase the diameter of the suction pipe - Shorten and simplify the suction piping.
3 Pump not purged.	Purge or fill.
4 Cavitation.	Increase suction pressure (see 2).
5 The pump sucks in air.	Check suction pipe and all its connections.
6 Suction pipe clogged.	Check the suction pipe and filter(s), if any.
7 Wrong setting of relief valve.	Check the relief valve's setting.
8 Discharge pressure too high.	If necessary, reduce the loss of head by increasing the diameter of the discharge pipe.
9 Viscosity of the liquid is too high.	- Reduce the pump speed. - Reduce the viscosity, for example, by heating the liquid.
10 Viscosity of liquid too low.	- Increase the pump speed. - Increase the viscosity, for example, by cooling the liquid.
11 Temperature of liquid too high.	Reduce the temperature by cooling the liquid.
12 Pump speed too high.	Reduce the pump speed.
13 The lobes are worn.	Replace the lobes.
14 Pump speed too low.	Increase the pump speed.
15 Product very abrasive.	Fit hardened lobe hubs.
16 Worn bearings.	Replace the bearings, check the pump.
17 Worn or damaged shaft sealing.	Replace the lip seal or/and the sleeve.
18 O-rings not the right ones for the liquid.	Fit the proper O-rings; check with the supplier.
19 Worn gears.	Replace and readjust the gears.
20 Insufficient lubricating oil level.	Fill up with oil.
21 Unsuitable lubricating oil.	Use an appropriate oil.
22 The lobes rub.	- Reduce the temperature. - Reduce the discharge pressure. - Adjust the clearance.
23 Coupling misalignment.	Align the coupling.
24 Tension on the pipelines.	Connect the pipelines to the pump free of tensions.
25 Foreign bodies in the liquid.	Insert a filter in the suction pipe.
26 Pump and / or electric motor not fixed on foundation.	Tighten, check that the piping has been connected stress-free and align the coupling.



**If the problem persists, use of the pump must cease immediately. Contact the pump's manufacturer or its representative.**

# 7 Maintenance

## 7.1 GENERAL MAINTENANCE

This pump, as with any other machine, needs to be maintained. The instructions contained in this manual deal with the identification and replacement of the spare parts. These instructions have been drawn up by maintenance staff and are destined for those people who are responsible for supplying spare parts.



Read carefully Chapter 8. *Technical specifications*.

All the parts or materials that are changed must be duly eliminated /recycled in accordance with the prevailing directives in each area.



ALWAYS disconnect the pump before starting out on any maintenance work.

### 7.1.1 Check the shaft sealing

Periodically check that there are no leaks in the shaft area. Should there be any leaks in the lip seal area, replace the same pursuant to the instructions given in the *Pump Disassembly and Assembly* section.

### 7.1.2 Dry thread torque

Material	Dry thread torque [N.m]								
	M5	M6	M8	M10	M12	M14	M16	M18	M20
8.8	6	10	25	49	86	135	210	290	410
A2	5	9	21	42	74	112	160	210	300

### 7.1.3 Lubrication

The bearings are oiled by immersion in an oil bath.  
The pumps are supplied with food grade oil :

#### Special lubricants for food industries

Oil temperature (°C)	Pump / ambient temp.	Lubricant type		Type	Approval
		Mineral	Synthetic		
-20°C à +120 °C	Ambient temp. < 40°C and all BLK4-T pumps with product temp. < 110°C		X	Castrol : Vitalube GS 220	USDA (H1)
			X	Kluber : Klüberoil 4UH- 220	USDA (H1)
			X	Mobil : DTE FM 220	FDA 178.3570 178.362 USDA (H1)a

NOTICE : SYNTHETIC AND MINERAL LUBRICANTS MUST NOT BE MIXED.

- Regularly check the oil level, for example, weekly or every 150 operating hours.
- The first oil change must be carried out after 150 hours of operation.
- Afterwards, it can be changed every 2500 operating hours or at least once a year when operating under normal conditions.  
When change the oil: the oil sump must be filled up to the level in the middle of the peephole.



Do not pour too much oil into the sump.

Leave the pump switched off for a while and then re-check the oil level; if necessary, add a little oil.

PUMP TYPE	Quantity of oil in the Gear Case (L)
BLK4-T	1,75

## 7.2 STORAGE

Before being stored the pump must be completely emptied of liquids. Avoid, as far as possible, the exposure of the parts to excessively damp atmospheres.

## 7.3 CLEANING

### 7.3.1 Manual cleaning



The use of aggressive cleaning products such as caustic soda and nitric acid may give rise to skin burns.

Use rubber gloves during the cleaning process.



Always use protective goggles.

### 7.3.2 Automatic CIP (cleaning-in-place)

If the pump is installed in a system fitted with a CIP process, there will be no need for stripping.

The recommended minimum liquid speed for an effective process of cleaning is  $1,8 \text{ m.s}^{-1}$  (minimum  $\text{Re} > 100\,000$  at 1,0–2,5 bar).

It is recommended to run the pump during the CIP process (rotation speed: same as nominal speed when used as pump).

If it is not fitted with an automatic cleaning process, strip the pump pursuant to the instructions given in the section entitled Stripping and Assembly of the pump.

#### Cleaning solutions for CIP processes.

Only use clear water (chloride free) to mix with the cleaning agents:

- a) Alkaline solution :** 1% in weight of caustic soda (NaOH) to 70°C (150°F)  
1 kg NaOH + 100 L water = cleaning solution  
or  
2,2 L NaOH to 33% + 100 L of water = cleaning solution
- b) Acid solution :** 0,5% in weight of nitric acid (HNO<sub>3</sub>) to 70°C (150°F)  
0,7 L HNO<sub>3</sub> to 53% + 100 L water = cleaning solution



**Monitor the concentration of cleaning solutions; it could give rise to the deterioration of the pump sealing gaskets.**

**These solutions are given as examples and should be validated before use on an application.**

In order to remove any remains of cleaning products, ALWAYS rinse the element in question with clean water after completing the cleaning process.

### 7.3.3 Automatic SIP (sterilization-in-place)

The process of sterilization with steam is applied to all the equipment including the pump.



**Do NOT start the pump during the process of sterilization with steam.**

**The parts/materials suffer no damage if the indications specified in this manual are observed.**

**No cold liquid can enter the pump till the temperature of the pump is lower than 60°C (140°F).**

**As the pump creates a high head loss during the sterilization process, we recommend the use of a second piping with a relief valve in order to ensure that the steam / overheated water could sterilize the whole installation.**

#### **Maximum conditions during the SIP process with steam or overheated water :**

- |    |                    |  |
|----|--------------------|--|
| a) | Max. temperature : | 140°C (284°F)  |
| b) | Max. time :        | 30 min   |
| c) | Cooling :          | Sterile air or inert gas                                 |
| d) | Materials :        | EPDM / PTFE (recommended)<br>FPM / NBR (not recommended) |

## 7.4 PUMP DISASSEMBLY

Assembly and disassembly of the pumps must only be carried out by qualified personnel. Ensure that the personnel read the entire instructions manual carefully, and particularly the instructions that refer to the job to be done.



**Incorrect assembly or disassembly can cause damage to pump operation leading to high repair costs and long operation downtime.**

**MOUVEX shall not be liable for accidents or damages caused as a result of failure to comply with the instructions set forth in this manual.**

### Preparations

Provide a clean working environment, as some parts, may require careful handling, while others have close tolerances. Check that the parts to be used have not been damaged during transport. When doing this, it is necessary to inspect the adjustment edge, matching faces, sealing, burrs, etc. After completing each disassembly process, carefully clean the parts and check for any damage. Replace all damaged parts.

### Tools

Use appropriate tools for the assembly and disassembly operations. Use them correctly.

### Cleaning

Before disassembling the pump, clean it on the outside and the inside.



**NEVER clean the pump manually while it is in operation.**

### 7.4.1 Pump cover disassembly



**CAUTION! Liquid may spill from the rotor case when removing the pump cover**

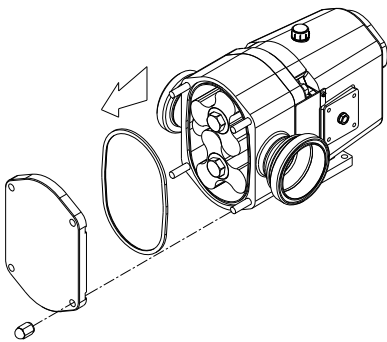

- Close the suction and discharge valves.
- Remove the cap nuts (45). Notches have been provided at four points around the pump cover (03) to help, if necessary, to remove it from the rotor case (that is, with a screwdriver).
- Check that the gasket (80A) is in good condition.

### 7.4.2 Unscrew lobes

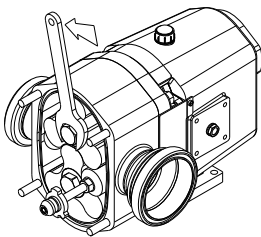

- Loosen the lobe screws (25) with a key of 30.
- These screws have a right-hand thread. To prevent the lobes turn simultaneously, the extractor handle supplied with the pump is inserted.
- Check that the O-ring (80) is in good condition.
- Remove the lobe washer (35).

### 7.4.3 Lobe disassembly

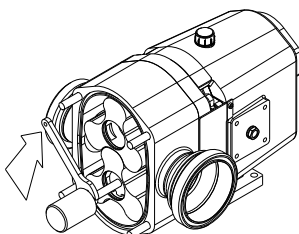

- Remove both lobes (02) using the extractor supplied with the pump, place the extractor in the grooves machined into the lobe for this purpose and unscrew the nut. If necessary, use a key of 19 to help.
- Remove the shims (32) fitted to each shaft. If there is more than one fitted to each shaft, keep them separate to prevent them from getting mixed up.

#### 7.4.4 Rotor case disassembly

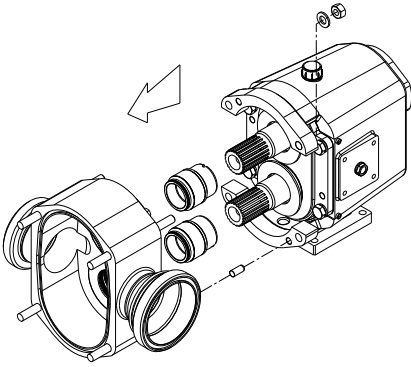

- Loosen and remove the nuts (54A) fixing the rotor case (01) to the gear case (06).
- Remove the sleeve (13) of the triple lip seal; check the O-ring (80D) of the sleeve.

#### 7.4.5 Triple lip seal disassembly

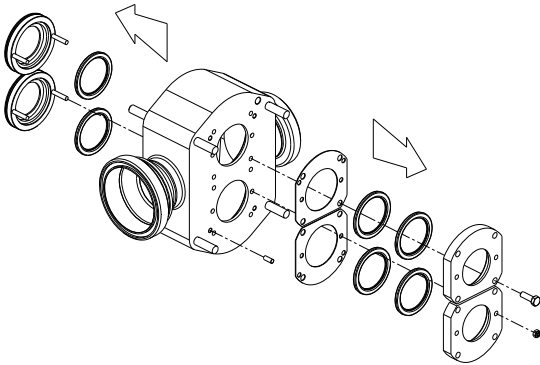

- Loosen and remove the nuts (57) fixing the seal cover (09) to the rotor case. Check the gasket (80B) of the seal cover.
- Loosen and remove the screws (52A) fixing the seal cover (09A) to the rotor case.
- Remove the lip seals (08D).

#### 7.4.6 Lubrication oil drainage

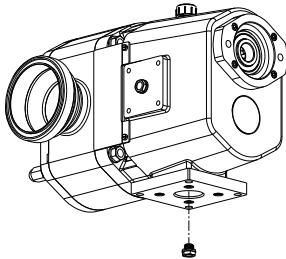

- Place a container underneath the gear case (06) to collect the lubricant oil so that it can be recycled.
- Remove the drainage plug (87) located at the rear of the gear case.

#### 7.4.7 Shaft assembly removal

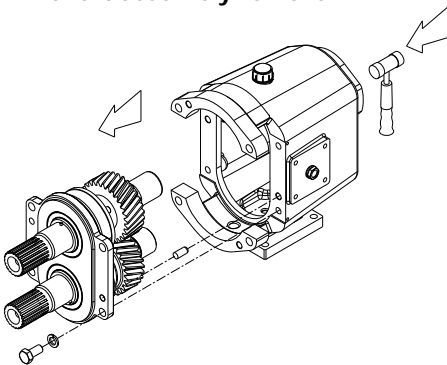

- Remove the screws (52) and washers (53A) that fix the bearings cover (12) to the gear case (06).
- Remove the shaft assembly from the gear case. Due to the tightness of the bearings cover (12), a nylon hammer must be used. Lightly tap the rear part of the driveshaft (05).
- Check the condition of the Klingerit seal (18A) once the shaft assembly has been removed, and if there are any defects, find a replacement before reassembling the pump.

## 7.5 PUMP ASSEMBLY

### 7.5.1 Shaft assembly



**CAUTION!** When re-assembling the gear case cover, take note of the position of the centring pins.

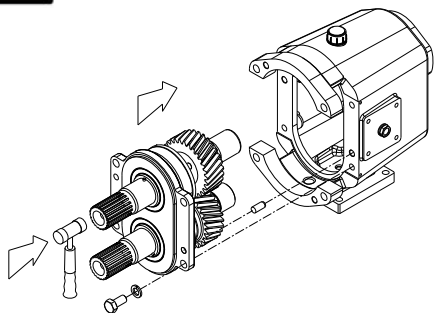

- Ensure that the Klingerit seal (18A) is in good condition, or if necessary replace it with a new one, and fit it to the gear case (06).
- Introduce the shaft assembly into the gear case (06) taking care when sliding the shaft (05) driven by the retainer (88).
- Use a nylon hammer and lightly tap the shafts (05 and 05A) until the bearings cover (12) is well fixed to the gear case (06).
- Fix the bearings cover (12) to the gear case (06) with the washers and screws (53A and 52).

### 7.5.2 Filling with lubricating oil

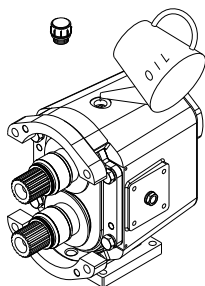

- Remove the oil plug (85) located at the top of the gear case (06).
- Fill the gear case (06) with lubricant oil up to the middle level of the peephole (86).

See 7.1.3 *Lubrication* to consult type and quantity of oil.

### 7.5.3 Triple lip seal assembly

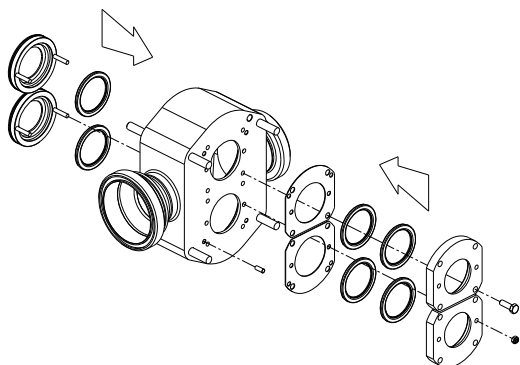

- Fill up the gap between the lip seals with food grade grease.
- Place the two lip seal gaskets (08D) on the seal cover (09A).
- Ensure that the Klingerit seal (18) is in good condition, or if necessary replace it with a new one, and fit it to the rotor case (01).
- Attach the seal cover (09A) to the rotor case (01) and fasten it on with screws (52A).
- Place one lip seal gaskets (08D) on the seal cover (09). Place the O-ring (80B) on the seal cover.
- Attach the seal cover (09) to the rotor case (01) and fasten it on with nuts (57).

#### 7.5.4 Rotor case assembly



**CAUTION!** When re-assembling the rotor case, take note of the position of the centring pins.

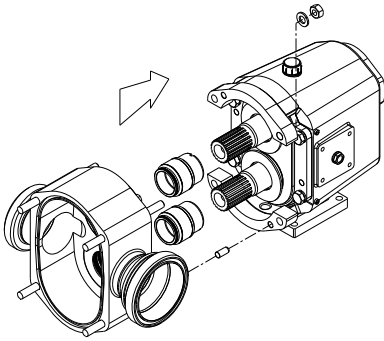

- Attach the sleeve (13) to the shaft, and place the O-ring (80D) on the sleeve.
- Mount the rotor case (01) on the gear case (06). Due to the tightness of the pins, it is necessary to use a nylon hammer. Lightly tap the rotor case until it is tight to the gear case.
- Fasten the nuts (54A) with the appropriate tightening torque.

#### 7.5.5 Lobe assembly



**ALWAYS** check the clearance between the lobes and between the lobes and the rotor case before finishing assembly. See 7.6.1 [Clearance and tolerance table](#)

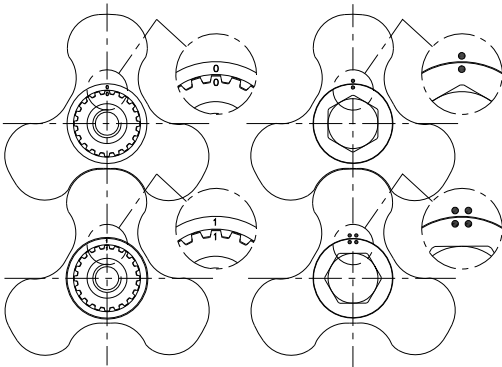

- Fit new O-rings (80) to the lobe screws (25).
- Lubricate the rings with soapy water or food grade oil.
- Adjust the shims (32) on the shafts (05 and 05A).
- See chapter 7.6.3 [Lobe/Pump Rotor case adjustment using shims](#).
- Place the lobes (02) on the shafts (05 and 05A) ensuring that the lobe and shaft markings (numbers 0 and 1) coincide.
- Tighten the lobe screws (25) using a key of 30 ensuring that the markings match. In order to prevent the lobes from turning simultaneously, place the extractor handle provided with the pump between the lobes.

#### 7.5.6 Pump cover assembly

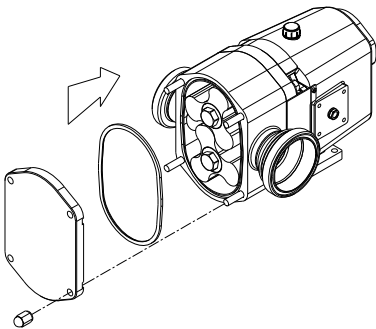

- Check that the front cover gasket (80A) is in good condition or, if applicable, replace it with a new one.
- Attach it to the rotor case (01), ensuring that no dirt or residue of any product remains in the seal or the rotor case.
- If it is necessary to lubricate the gasket to assist in fitting it, use soapy water or food grade oil.
- Place the pump cover (03) onto the rotor case (01) and tighten the blind nuts (45).
- See chapter 5.1.1 [Inspections to be carried out before starting up the pump](#).

## 7.6 LOBE ADJUSTMENT

### 7.6.1 Clearance and tolerance table

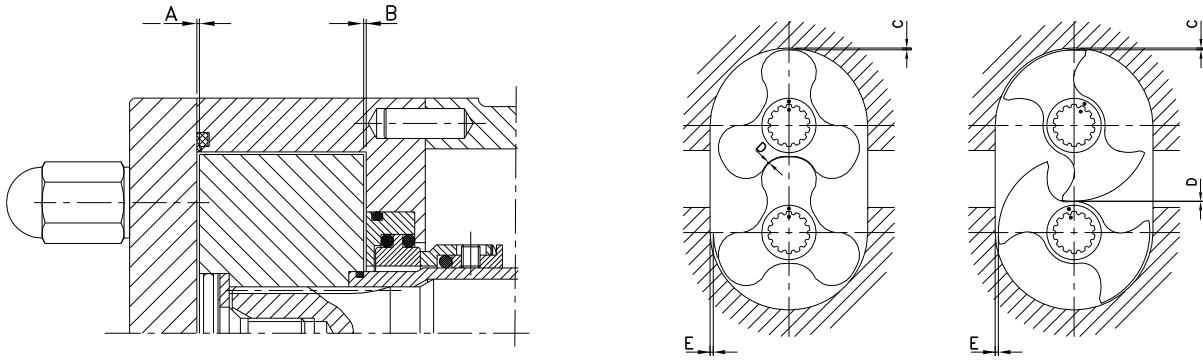

(mm)	A	B	C	D	E
<b>BLK4-T</b>	0,3 ±0,05	0,2 ±0,05	0,3 ±0,1	0,2 ±0,05	0,5 ±0,1

A = axial clearance between the lobe and the cover.

B = axial clearance between the lobe and the rear of the rotor case.

C = radial clearance between the lobe and the rotor case.

D = radial clearance between the lobes.

E = radial clearance between the lobe and the rotor case on the suction side.

Dimensions in mm

### 7.6.2 Synchronizing the lobes

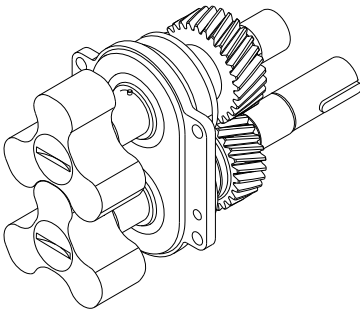

- In order to enable the lobes to be tightened, it is necessary to remove the shaft assembly from the gear, and mount the lobes (02) on the shafts fixing them with screws (25).

- Loosen the tightening screws from the adjustable fastening mechanism for the idler gear (19A). In principle, the adjustable fastening mechanism is easy to disassemble. It is now possible to rotate the driveshaft (05) while holding the idler shaft still (05A).

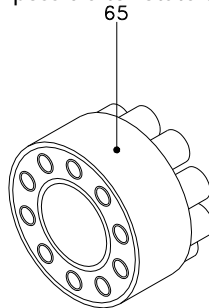

The adjustable fixing mechanism is a single piece (65).

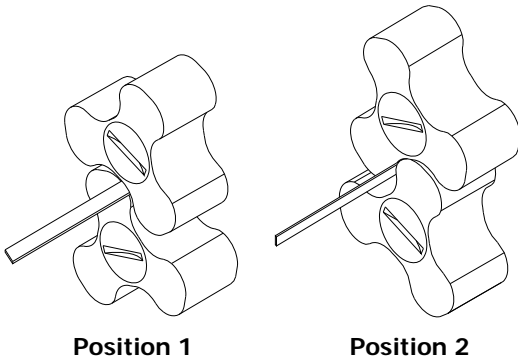

- Slide the lobes (25) over the shafts (05 and 05A) as indicated in 7.5.5 [Lobe assembly](#).
- Turn the lobes to the position indicated in position 1 until the gap is as indicated in 7.6.1. [Clearance and tolerance table](#).
- Tighten manually several tightening screws in the adjustable fixing mechanism.
- Then turn the upper lobe about 60° to the left (position 2). Check that the gap in this position is equal to the position. If not, these gaps should be equalized by turning one lobe slightly while holding the other still.

- Tighten the tightening screws of the adjustable fixing mechanism diagonally by 2 or 3 turns with the established tightening torque.
- When tightening the screws of the adjustable fixing mechanism (51A), ensure that the gears (19 and 19A) do not turn in relation to each other. This can be avoided by placing a wooden wedge between the gears (19 and 19A).
- Check again the gap between the lobes (02) and turn the driveshaft (05) a few times in order to check that the lobes (02) do not rub against one another at any point.
- Remove the lobes (02) from the shafts (05 and 05A).
- Apply a little lubricant to the driveshaft (05) at the location of the retainer (88) once assembly is finished.

### 7.6.3 Lobe/Rotor case adjustment using shims

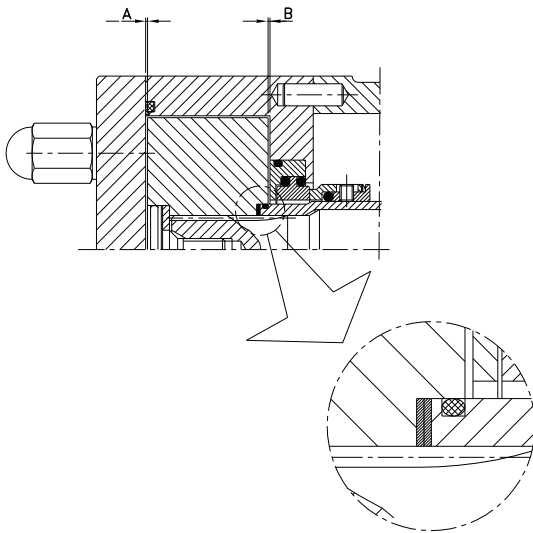

- This is the final adjustment to be carried out. The pump must be synchronized and the rotor case must be mounted on the gear case.
- The adjustment is made using ring-shaped shims (32) placed between the sleeve (13) and the lobe (02).
- There are 3 different shim thicknesses (0.05, 0.1, and 0.2 mm).
- Assemble a complete set of shims for each lobe, and place the seal cover (29) to the rotor case (01).
- Mount the lobes (02) and tighten the screws (25) as described in 7.5.5. [Lobe assembly](#).
- Check the tolerances between the lobe and rotor case (A and B). See 7.6.1. [Clearance and tolerance table](#). If they are out of range, change the shims until the necessary clearance is achieved.

# 8 Technical Specifications

## 8.1 TECHNICAL SPECIFICATIONS

Theoretical displacement volume x 100 rev. ....	95,3 litres
Maximum flow rate .....	41,2 m <sup>3</sup> /h (181 US gpm)
Maximum working pressure .....	7 bar (102 psi)
Maximum temperature <sup>(1)</sup> .....	110 °C (230 °F)
Maximum viscosity <sup>(2)</sup> (recommended) .....	100,000 mPa.s
Maximum speed .....	720 rpm
Ports diameters .....	80 or 100
Connections.....	DIN or SMS

- (1) Maximum temperature for continuous application due to EPDM gaskets and standard lobe rotor clearances. To consult for higher temperatures.  
 (2) Maxim viscosity allowed will depend on the nature of the liquid and the sliding of the seal faces.

Consult MOUVEX for higher viscosity levels.



**Use special protection if the noise level in the operation area exceeds 85 dB (A)**

Pump size	n <sub>max.</sub> [rpm]	B <sub>1</sub> [mm]	D <sub>1</sub> [mm]	V <sub>s-100</sub> [l]	Q <sub>th</sub> [m <sup>3</sup> /h]	P <sub>max.</sub> [bar]	V <sub>u</sub> (m/s)	V <sub>i</sub> (m/s)
BLK4-T	720	76	131,5	95,3	41,2	7	4,96	2,22

n <sub>max.</sub>	Maximum speed
B <sub>1</sub>	Lobe width
D <sub>1</sub>	Lobe diameter
V <sub>s-100</sub>	Theoretical displacement volume x 100 rev.
Q <sub>th</sub>	Maximum theoretical flow rate at n <sub>max.</sub>
P <sub>max.</sub>	Maximum differential pressure
V <sub>u</sub>	Peripheral speed
V <sub>i</sub>	Maximum entry speed

### Materials

Parts in contact with the product .....	AISI 316L
Other stainless-steel parts .....	AISI 304
Product wetted gaskets .....	EPDM
Lip seals .....	PTFE
Product wetted parts surface finishing .....	Ra < 0.8 µm

### Heating jacket

Maximum temperature .....	180 °C (356 °F)
Maximum pressure .....	4 bar (58 psi)

### 8.1.1 Size of particles



**WARNING!** Only soft particles.  
< 10 % damage when using trilobes geometry.

Pump size	Internal connection diameter [mm]	Maximum theoretical sphere frame [mm]	Recommended maximum theoretical sphere frame [mm]
BLK4-T	72,2	38,5	13

### 8.1.2 Torque

Maximum torque in the pump shaft.

Pump size	(N.m.)
BLK4-T	400

### 8.2 WEIGHT

Pump size	Pump (kg)
BLK4-T	63

### 8.3 BLK4-T PUMP DIMENSIONS

#### 8.3.1 Hollow shaft

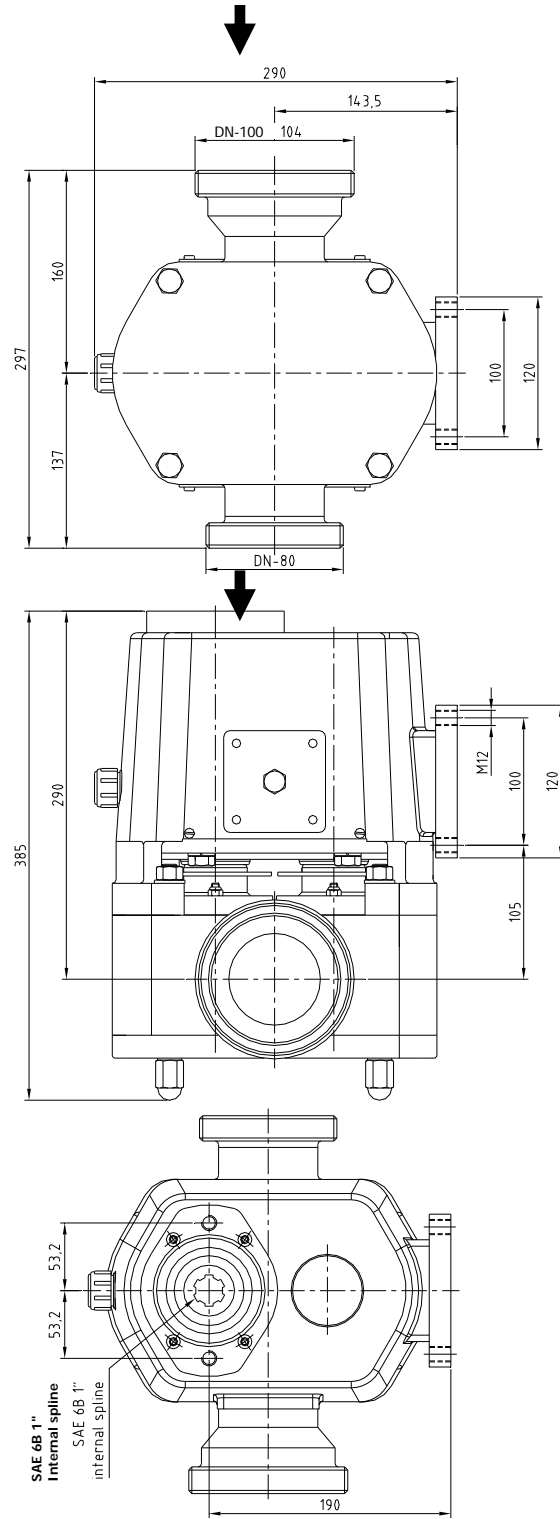

### 8.3.2 External shaft

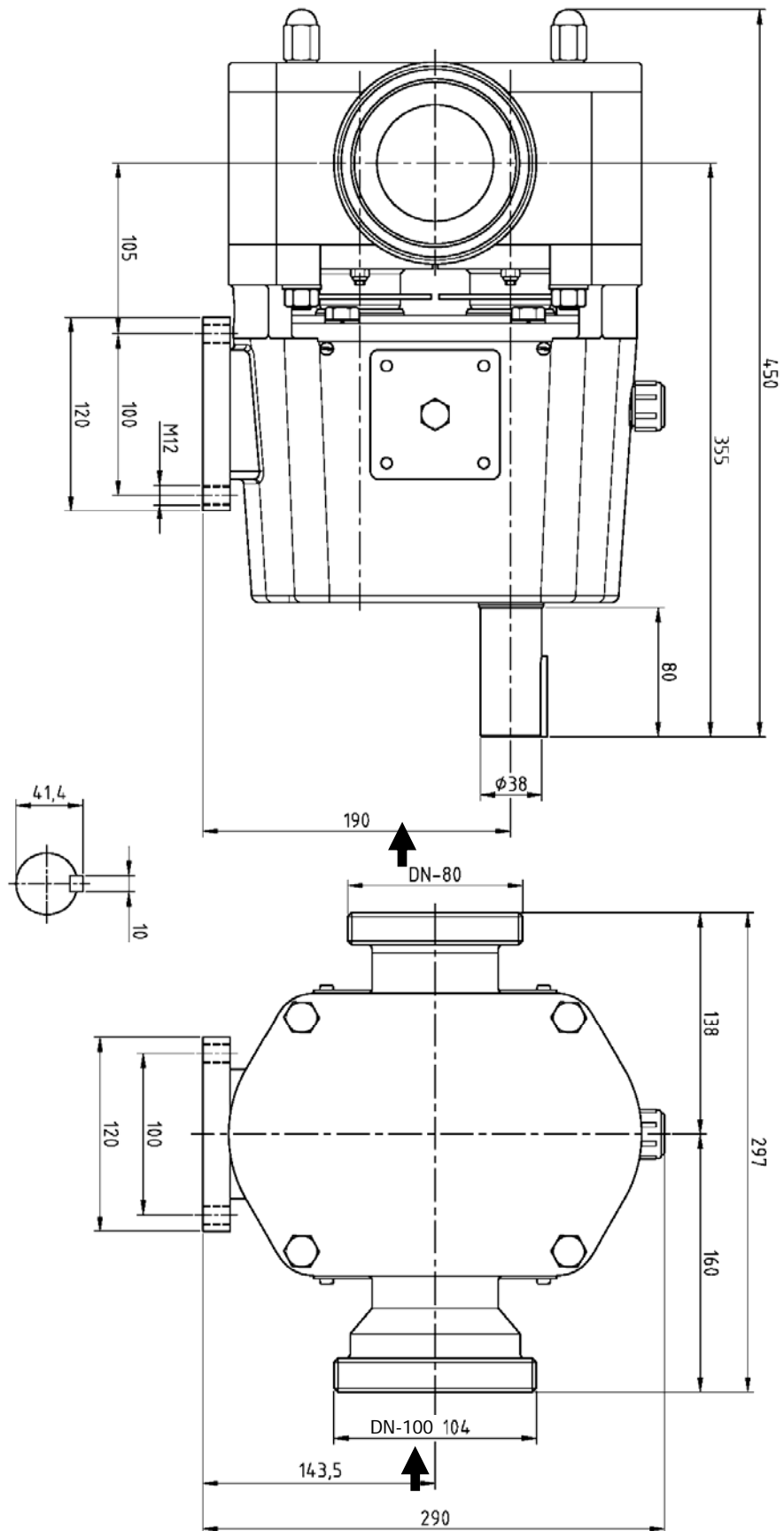

## 8.4 BLK4-T EXPLODED VIEW

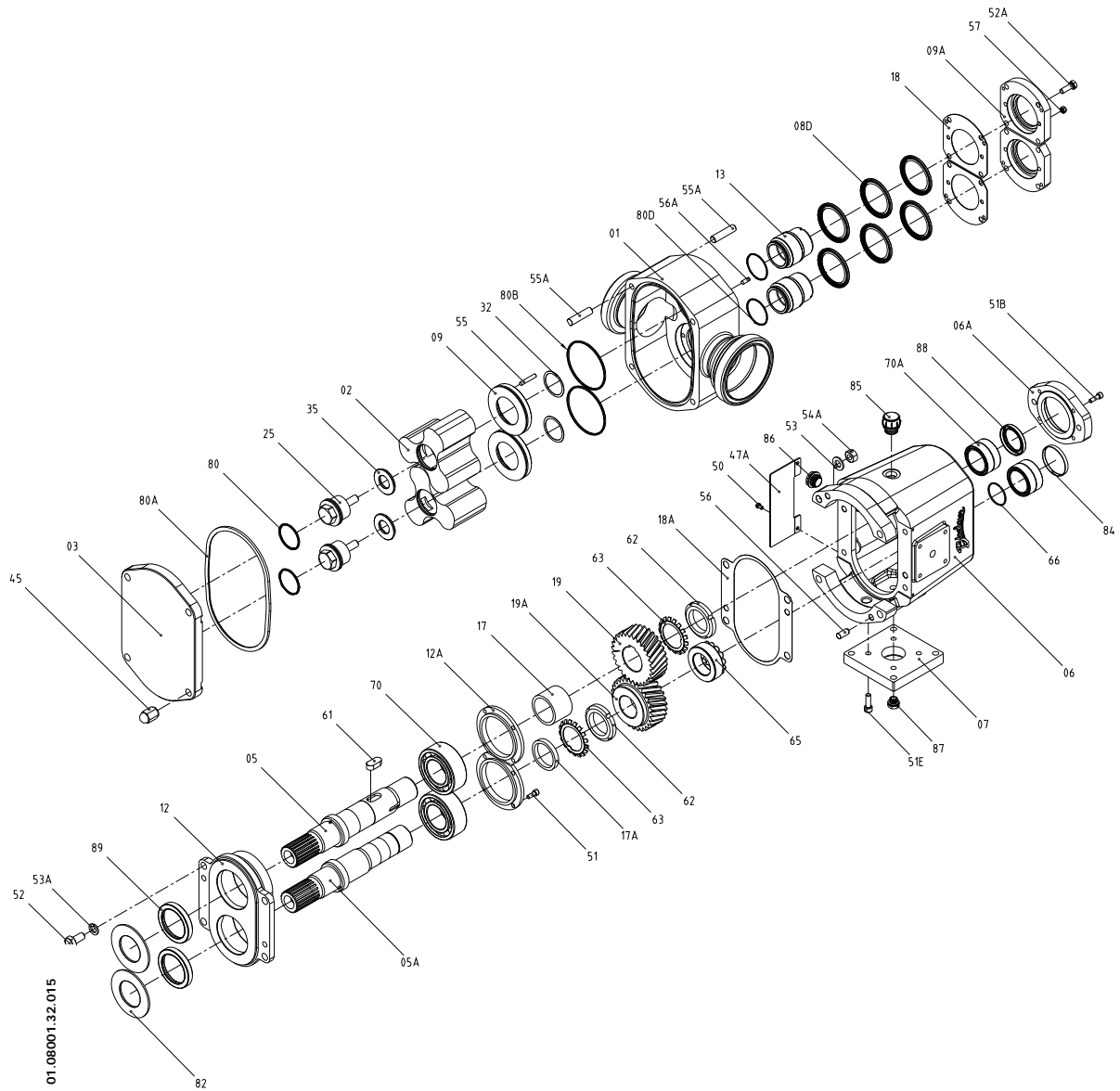

#### 8.4.1 Spare parts

Pos.	Description	Qty	Material
01	Rotor case	1	AISI 316L
02	Rotor	2	AISI 316L
03	Front cover	1	AISI 316L
05	Drive shaft	1	AISI-329
05A	Driven shaft	1	AISI-329
06	Gear case	1	GG-22
06A	Hydraulic motor support	1	F-111
07	Support, horizontal ported	1	AISI 304
08D	Lip seal	6	PTFE
09	Seal cover	2	AISI 316L
09A	Seal cover	2	AISI 316L
12	Bearing cover	1	GG-22
12A	Bearing stop flange	2	GG-22
13	Sleeve, seal	2	AISI 316L
17	Drive shaft bushing	1	ST-52
17A	Driven shaft bushing	1	ST-52
18	Seal cover gasket	2	RivathermS
18A	Bearing cover gasket	1	Klingerit
19	Driver shaft gear	1	F-154
19A	Driven shaft gear	1	F-154
25	Lobe screw	2	AISI 316L
32	Shim	2	St. St.
35	Rotor washer	2	AISI 316L
45	Wing nut	4	AISI 304
47A	Protector	2	AISI 304
50	Screw	4	Stainless steel
51	Allen screw	8	8.8
51B	Allen screw	4	8.8
51E	Allen screw	4	Stainless steel
52	Hexagonal screw	4	8.8
52A	Hexagonal screw	8	Stainless steel
53	Flat washer	4	8.8
53A	Grower washer	4	8.8
54A	Hexagonal nut	4	Stainless steel
55	Stud	4	Stainless steel
55A	Stud	8	Stainless steel
56	Pin	2	F-522
56A	Pin	4	Stainless steel
57	Self-locking nut	4	Stainless steel
61	Key	1	F-114
62	Safety nut	2	Steel
63	Safety washer	2	Steel
65	Conical tightening ring	1	Steel
66	Circlip	1	Steel
70	Ball bearings	2	Steel
70A	Needle bearings	2	Steel
80	O-ring	2	-
80A	Front cover gasket	1	-
80B	O-ring	2	-
80D	O-ring	2	-
82	Splash ring	2	EPDM
84	Blanking plug	1	72 NBR
85	Oil plug	1	Plastic
86	Peephole	1	Plastic
87	Bleeder	2	Plastic
88	Lip seal	1	72 NBR
89	Lip seal	2	72 NBR

(\*) Quantity of shims may vary from one pump to another.

## 8.4.2 Triple lip seal

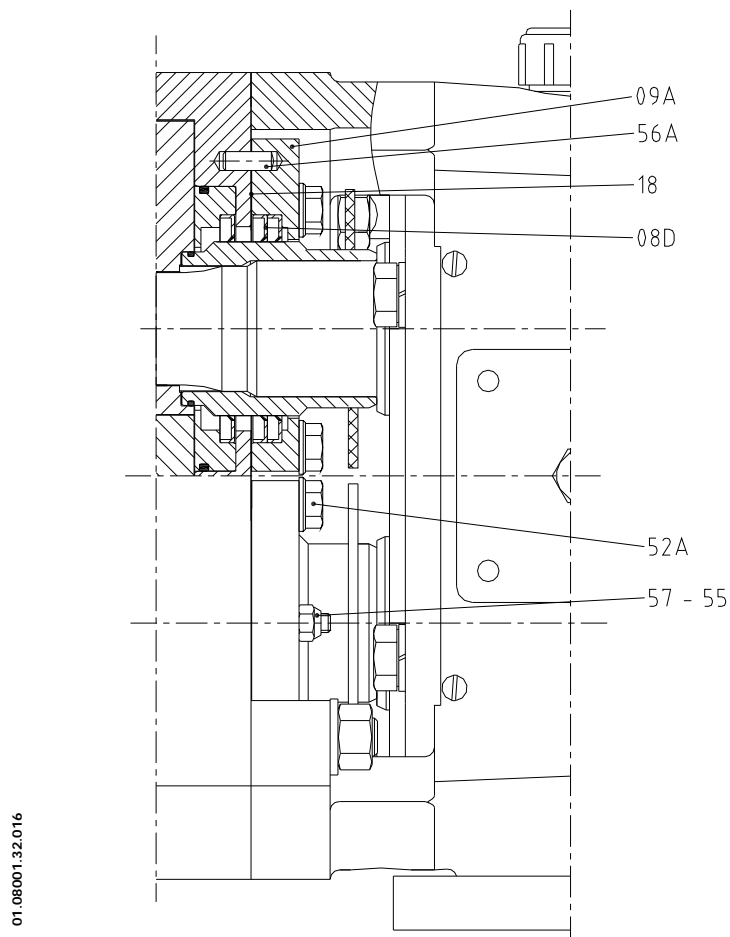

Position	Quantity	Description	Material
08D	6	Lip seal	PTFE
09A	2	Seal cover	AISI 316L
18	2	Seal cover Gasket	RivathermS
52A	8	Hexagonal screw	Stainless steel
55	4	Stud	Stainless steel
56A	4	Pin	Stainless steel
57	4	Self-locking nut	Stainless steel

## 8.5 SCRAPPING

The pump must be scrapped in compliance with the regulations in force.

During this operation, particular care must be paid to the drainage stages of the pump (pumped product) and of its transmission (lubricant).

# 9 Certificate of conformity



## CERTIFICATE OF CONFORMITY CE

**Mouvex**, ZI La Plaine des Isles - Rue des Caillottes - 89000 Auxerre France, declares the following equipment :

- Set-up :     Pump / Compressor « bare-shaft »     Pumping Unit / Compressor Unit
- Type :         Eccentric Disc Pump                     Vanes Pump                     Lobes Pump
- Peristaltic Pump                     Centrifugal Pump             Other Pump
- Screws compressor                     Vanes compressor             Hydraulic cooler

Designation : \_\_\_\_\_ s/n° : \_\_\_\_\_

According to the specifications recorded in the file N° : \_\_\_\_\_

is in conformity with the provisions of the following Directive :

- « **MACHINES** » **Directive 2006/42/EEC** as transposed by the national legislation, concerning safety equipments and arrangements relative to mechanical and electric risks applicable to rotative machines.  
NF EN 809:2009      NF EN 1672-2:2009      NF EN ISO 13857:2008      NF EN 12162:2009

And with the following marking :  **II2 G c IIB-T4    Max T° Flow = 80°C**

is in conformity with the provisions of the following Directive :

- « **ATEX** » **Directive 94/9/EC** (23 march 1994) as transposed by the national legislation, concerning equipment intended to be used in explosive atmospheres. Conformity obtained by application of the standards :  
NF EN 1127-1:1997      NF EN 13463-1:2009      NF EN 13463-5:2009

ATEX Certification delivered by INERIS, Notified Body (*INERIS - Parc Technologique Alata – 60550 Verneuil-en-Halatte - France*).

The equipment indicated above must be used according to the foreseen use by its design and its manufacturing, and according to the current standards.

We, undersigned, declare that the concerned equipment is in conformity with the Directives listed above and in the applicable standards in force.

For Mouvex SAS Company.

Date : \_\_\_\_\_



Quality Manager

**MOUVEX sas** : Z.I La Plaine des Isles – 2, rue des Caillottes - 89000 AUXERRE – France – SAS au capital de 8 496 855 €  
Tél : (33) 3.86.49.86.30 – Fax : (33) 3.86.46.42.10 – RCS AUXERRE 389 236 548 – APE 291 B – FR 85 389 236 548  
[www.mouvex.com](http://www.mouvex.com)

