

Section	1401
Effective	November 2011
Replaces	June 2011

Original instructions

LS-DDNC

Instructions for application

DIRECT DRIVE PACKAGE

B600 - MISTRAL - TYPHON II

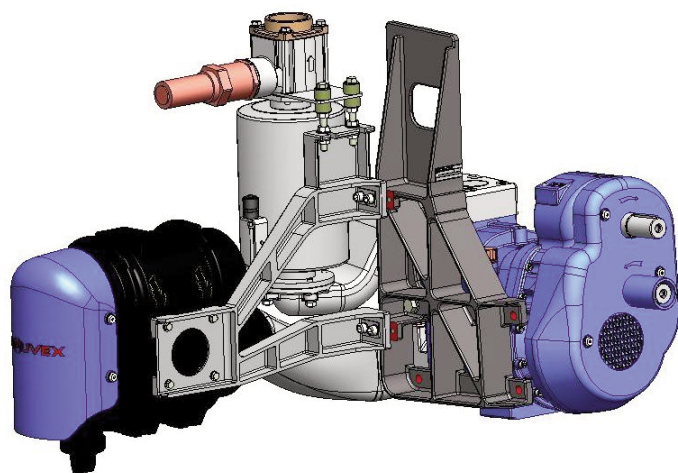

INSTALLATION
OPERATION
MAINTENANCE
SAFETY
STORAGE



This Instruction only contains direct drive package information. It is imperative to have in complement the compressor one and also all the others relatives to the accessories, also the parts list before installing the equipment.



Z.I. La Plaine des Isles - F 89000 AUXERRE - FRANCE
Tel. : +33 (0)3.86.49.86.30 - Fax : +33 (0)3.86.49.87.17
contact@mouvex.com - www.mouvex.com

Your distributor :

MOUVEX TRUCK SCREW COMPRESSOR

SAFETY, STORAGE, INSTALLATION, OPERATION AND MAINTENANCE INSTRUCTIONS

MODELS : LS-DDNC

DIRECT DRIVE PACKAGE

B600 - MISTRAL - TYPHON II

SAFETY INFORMATIONS



This is a SAFETY ALERT SYMBOL

When you see this symbol on the product, or in the manual, look for one of the following signal words and be alert to the potential for personal injury, death or major property damage.



Warns of hazards that **WILL** cause serious personal injury, death or major property damage



Warns of hazards that **CAN** cause serious personal injury, death or major property damage.



Warns of hazards that **CAN** cause personal injury or property damage.

NOTICE

Indicates special instructions which are very important and must be followed.

REMARKS :

MOUVEX truck screw-type compressors **MUST** be installed in systems designed by qualified personnel. The installation **MUST** be in compliance with local standards, national regulations and rules of safety.

This manual is designed to permit installation and commissioning of MOUVEX truck screw-type compressors and MUST accompany the compressor.

Maintenance of MOUVEX screw-type compressors must ONLY be carried out by qualified technicians. This maintenance must meet local and national standards as well as all safety regulations. Read this manual, including all instructions and warnings, in full BEFORE any use of MOUVEX compressors.

Do not remove the warning and use label stickers that are found on the compressors.

TABLE OF CONTENTS

Page

1. OVERALL DIMENSIONS	4
2. INSTALLATION	10
2.1 Mounting location	10
2.2 Mounting procedure	10
2.3 At suction	11
2.4 Safety valve / Check relief	11
2.5 Drive	11
2.6 Instrumentation	12
2.7 Chair modification	12
3. MAINTENANCE	13
3.1 Maintenance schedules	13
3.2 Air filter replacement procedure	13
3.3 Cartridge replacement procedure	13
3.4 Drive train inspection	13
3.5 Check valve and relief valve inspection	13
3.6 Warranty claims	13
4. TROUBLESHOOTING	14
5. STORAGE CONDITIONS	14
6. USE	14
7. SCRAPPING	14
8. COMPRESSORS FORM INFORMATION	15
9. CERTIFICATE OF CONFORMITY	16

ADDITIONAL DOCUMENTATION

The table below gives the list of instructions in addition to this application instruction :

LS-DDNC application	Instructions	Parts list
B600 20R/30R	NT 1401-K00	PL 1401-K01 PL 1401-W01
B600 13R/15L B600 19R/22L	NT 1401-K00	PL 1401-K01 PL 1401-Q01 PL 1401-W01
MISTRAL 20R/30R	NT 1401-J00	PL 1401-J01 PL 1401-W01
MISTRAL 13R/15L MISTRAL 19R/22L	NT 1401-J00	PL 1401-J01 PL 1401-Q01 PL 1401-W01
TYPHON II 20R/30R	NT 1401-G00	PL 1401-G01 PL 1401-W01
TYPHON II 13R/15L TYPHON II 19R/22L	NT 1401-G00	PL 1401-G01 PL 1401-Q01 PL 1401-W01
Torque limiter	NT 1401-B00	-
Check and relief valve	NT 1401-E00	-

SAFETY DATA

⚠ WARNING



Hazardous machinery can cause severe personal injury or property damage.

IT IS IMPERATIVE TO APPLY THE TRUCK PARKING BRAKE AND TO BLOCK THE WHEELS BEFORE ANY INTERVENTION DUE TO RISKS OF SERIOUS BODILY INJURIES OR PROPERTY DAMAGE.

⚠ WARNING



Hazardous fluids can cause fire, serious personal injury or property damage.

COMPRESSING GASES INTO A VESSEL CONTAINING FLAMMABLE OR EXPLOSIVE GASES, OR COMPRESSING FLAMMABLE OR EXPLOSIVE GASES, CAN CAUSE PROPERTY DAMAGE, PERSONAL INJURY OR DEATH.

⚠ CAUTION



Hazardous pressure can cause personal injury or property damage.

FAILURE TO INSTALL ADEQUATELY SIZED PRESSURE RELIEF VALVE(S) CAN CAUSE PROPERTY DAMAGE, PERSONAL INJURY OR DEATH

⚠ CAUTION



Extreme heat can cause injury or property damage.

COMPRESSOR, PIPING AND ACCESSORIES WILL BECOME HOT DURING OPERATION AND CAN CAUSE SERIOUS PERSONAL INJURY.

⚠ WARNING



Hazardous or toxic fluids can cause serious injury.

CONTENTS OF THE COMPRESSOR, TANK, PIPING, AND FILTERS COULD BE HAZARDOUS TO HEALTH. TAKE ALL NECESSARY PRECAUTIONS WHEN PERFORMING COMPRESSOR SERVICE OR MAINTENANCE.

⚠ WARNING



A loud noise can cause permanent body damage.

THE NOISE EMITTED BY WORKING MOUVEX SCREW COMPRESSOR CAN BE HIGHER THAN 80 DBA. THE END USERS MUST USE, WHEN NECESSARY THE APPROPRIATE EAR PROTECTIONS. FAILURE TO WEAR HEAR PROTECTIONS IN AREAS WHERE THE NOISE IS HIGHER THAN 80 DBA CAN LEAD TO PERMANENT BODY DAMAGE.

SAFETY CHECK LIST

1. Before operating the compressor, ensure the vessel to which the compressor is connected is certified to withstand the pressure and /or vacuum produced.
2. Verify adequately sized relief valves (if necessary, CE approved) have been fitted to protect the vessel. Do not use solvents or inflammable products for cleaning the pipelines and the accessories.
3. Gas/air mixtures which are potentially volatile/explosive must not be introduced or allowed to be introduced into the compressor.
4. All pressure vessel and piping connected to the compressor must be isolated and in a safe operating condition.
5. Operators should wear ear protection when operating truck mounted compressors.
6. There are components within the compressor of sufficient weight to cause injury if mishandled. Use proper lifting devices as necessary.
7. Where necessary, this equipment should be grounded to control static electricity.
8. The temperature of the air leaving the compressor is elevated above ambient due to air compression. Check that the elevated temperatures do not adversely affect the product and any material used in design of the system. Attach clearly marked warning signs to warn of potentially hot surfaces on the compressor, piping and accessories which will burn if touched.
9. Mounting of the compressor must be correctly engineered and the compressor must be properly secured. Refer to the Compressor Mounting section of this manual.

NOTICE :

MOUVEX COMPRESSORS ARE NOT DESIGNED FOR HANDLING LIQUID, POWDER OR CONDENSATE. TO DO SO WILL VOID THE WARRANTY.

LIFTING POINTS :

The compressor can be picked up from underneath to be transported.

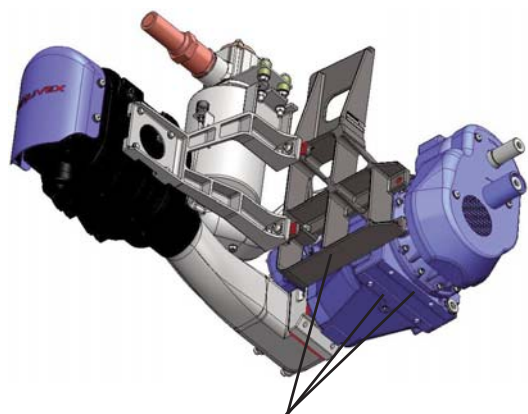

Those areas are acceptable to support the package. Compressor and chair support should be favored.

1. OVERALL DIMENSIONS

B600 20R - 30R LS-DDNC

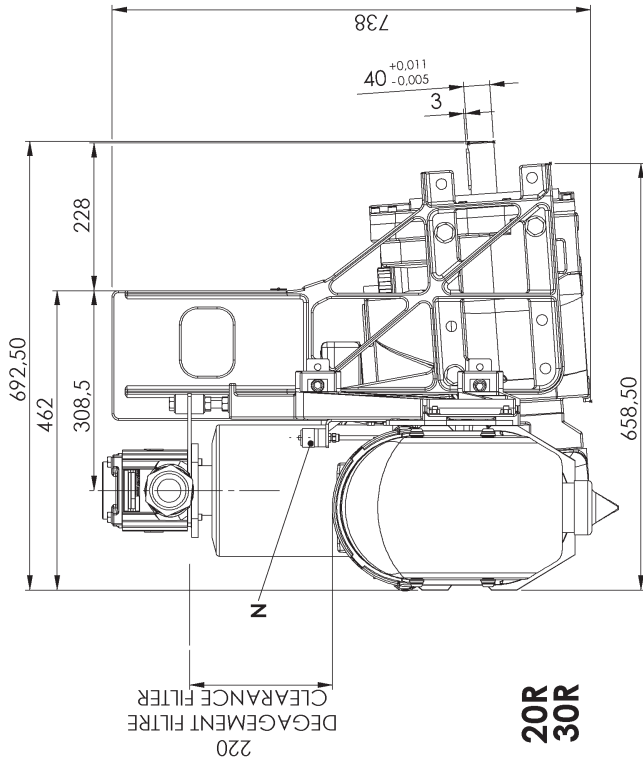

Poids avec limiteur de couple
Weight with torque limiter :
161 kg

A	Jauge d'huile / Oil gauge
B	Filtre à huile / Oil filter
C	Vidange / Draining cap
D	Contrôle pression G1/4" / Pressure control G1/4"
E	Contrôle T° G1/4" / T° control G1/4"
F	Plaque signalétique / Identification plate
G	Prise pression huile / Oil pressure plug
H	Bouchon 3/4" (pour montage jauge d'huile à droite) 3/4" cap for right oil gauge installation
J	Prise vitesse G1/4" / Speed control G1/4"
M	Bouchon magnétique G3/8" / Magnetic plug G3/8"
N	Indicateur de colmatage / Restriction indicator

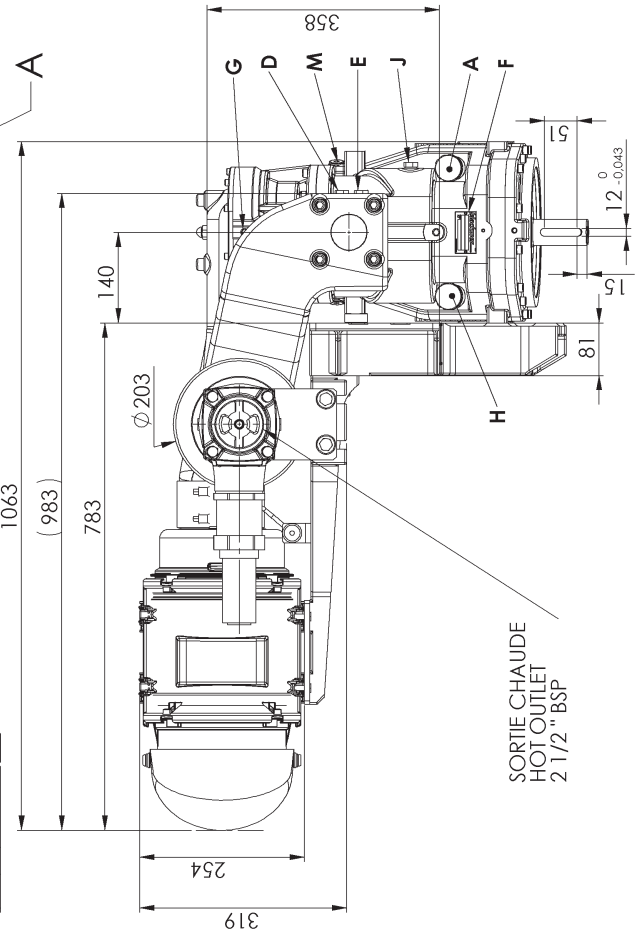
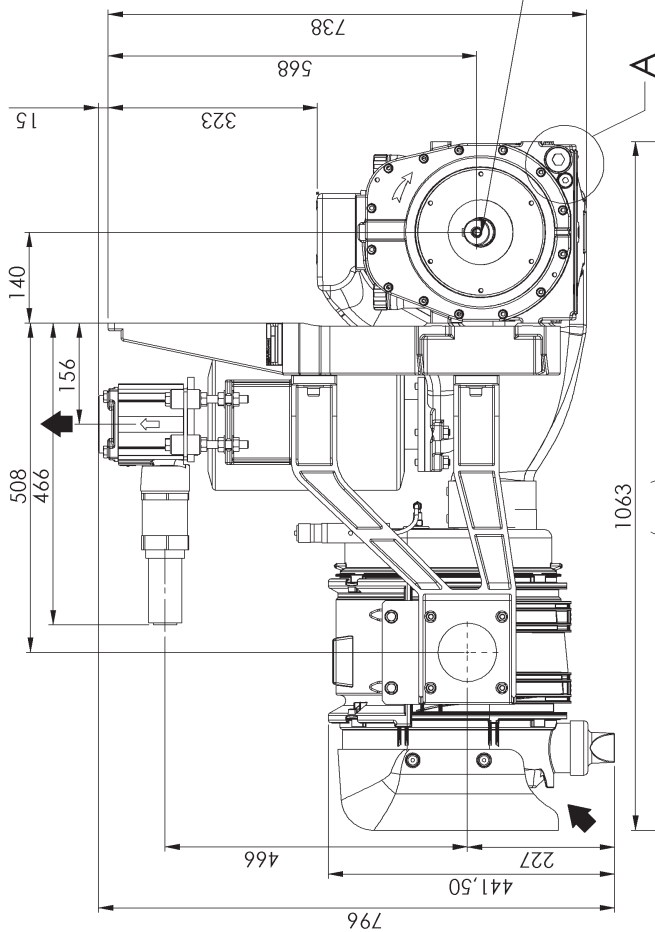
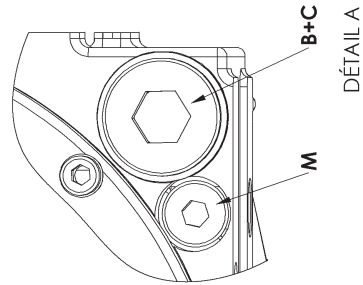

SORTIE CHAUDE
HOT OUTLET
2 1/2" BSP

1. OVERALL DIMENSIONS (continued)

B600 13R/15L - 19R/22L LS-DDNC

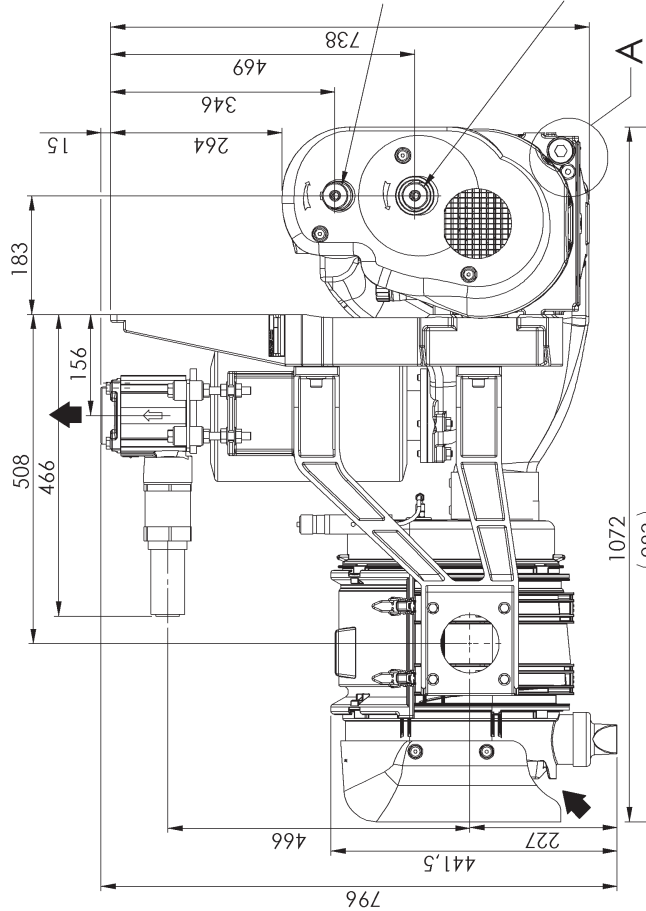
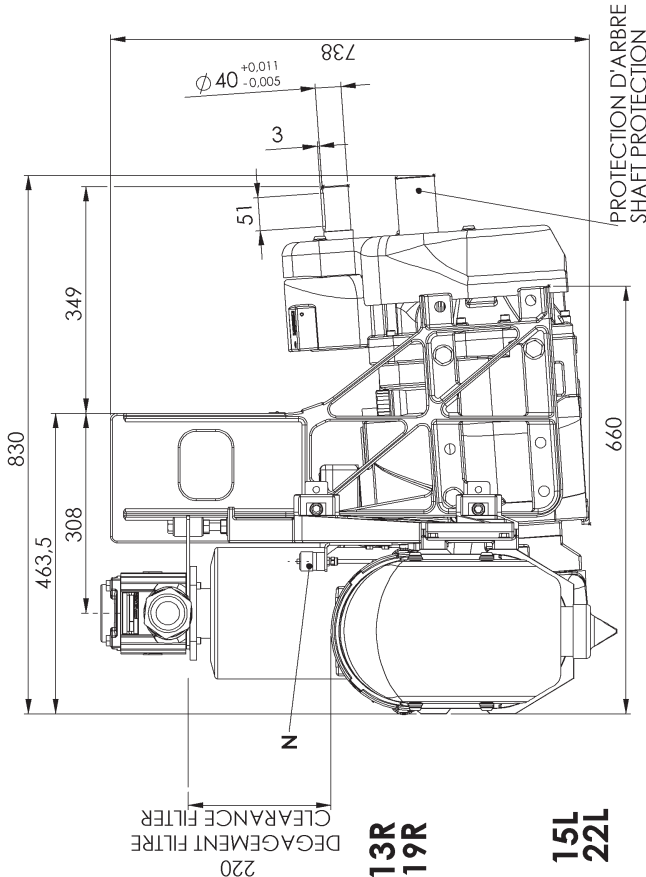

Poids avec limiteur de couple
Weight with torque limiter :
191 kg

A	Jauge d'huile / Oil gauge
B	Filtre à huile / Oil filter
C	Vidange / Draining cap
D	Contrôle pression G1/4" / Pressure control G1/4"
E	Contrôle T° G1/4" / T° control G1/4"
F	Plaque signalétique / Identification plate
G	Prise pression huile / Oil pressure plug
H	Bouchon 3/4" (pour montage jauge d'huile à droite) 3/4" cap for right oil gauge installation
J	Prise vitesse G1/4" / Speed control G1/4"
M	Bouchon magnétique G3/8" / Magnetic plug G3/8"
N	Indicateur de colmatage / Restriction indicator

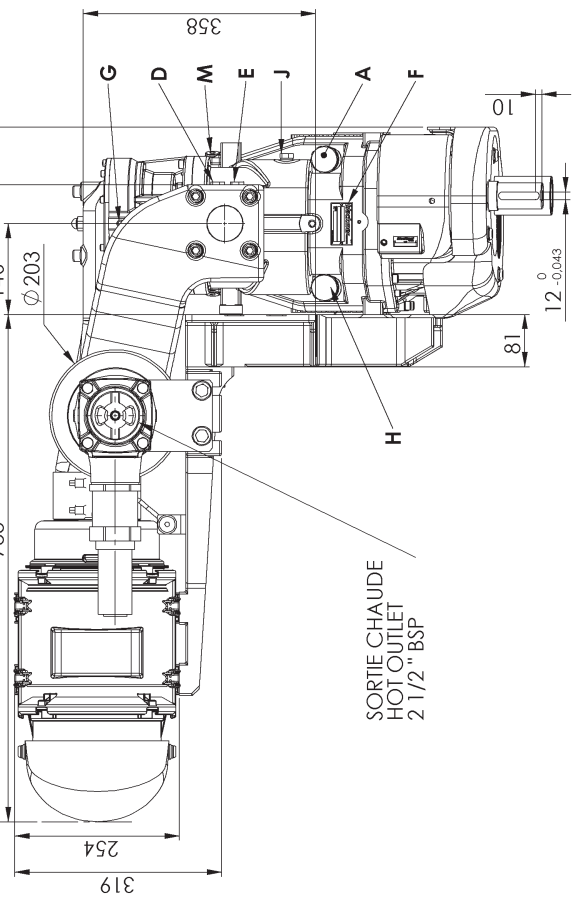
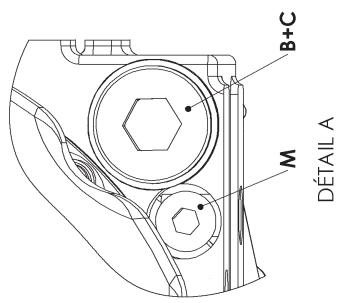

1. OVERALL DIMENSIONS (continued)

MISTRAL 20R - 30R LS-DDNC

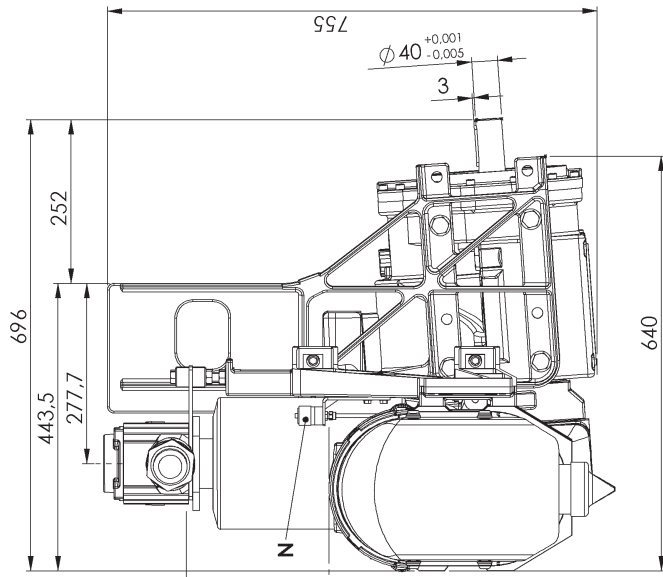

220
DEGAGEMENT FILTER
CLEARANCE FILTER

20R
30R

Poids avec limiteur de couple
Weight with torque limiter :
186 kg

A	Jauge d'huile / Oil gauge
B	Filtre à huile / Oil filter
C	Vidange / Draining cap
D	Contrôle pression G1/4" / Pressure control G1/4"
E	Contrôle T° G1/4" / T° control G1/4"
F	Plaque signalétique / Identification plate
G	Prise pression huile / Oil pressure plug
H	Bouchon 3/4" (pour montage jauge d'huile à droite) / 3/4" cap for right oil gauge installation
M	Bouchon magnétique G3/8" / Magnetic plug G3/8"
N	Indicateur de colmatage / Restriction indicator

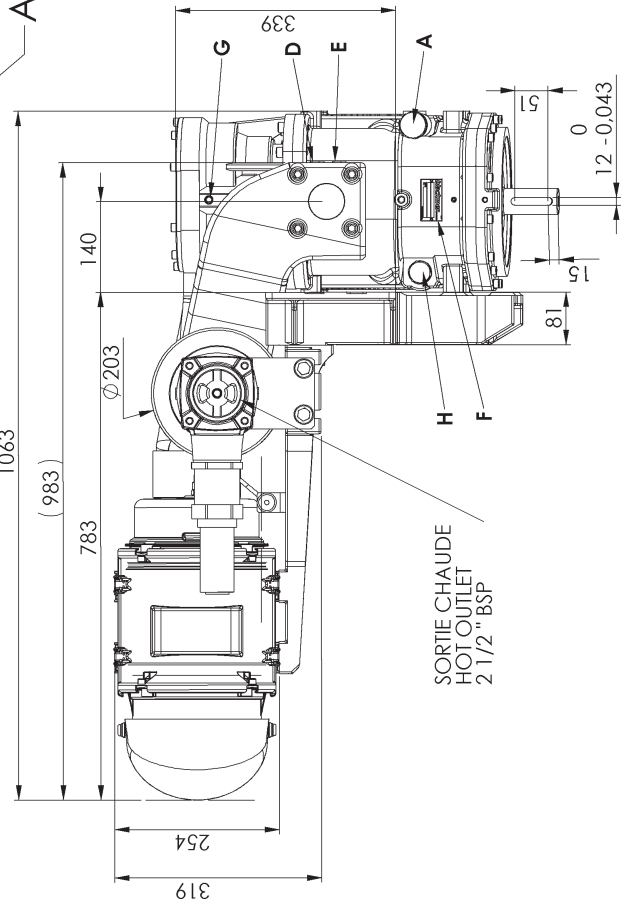
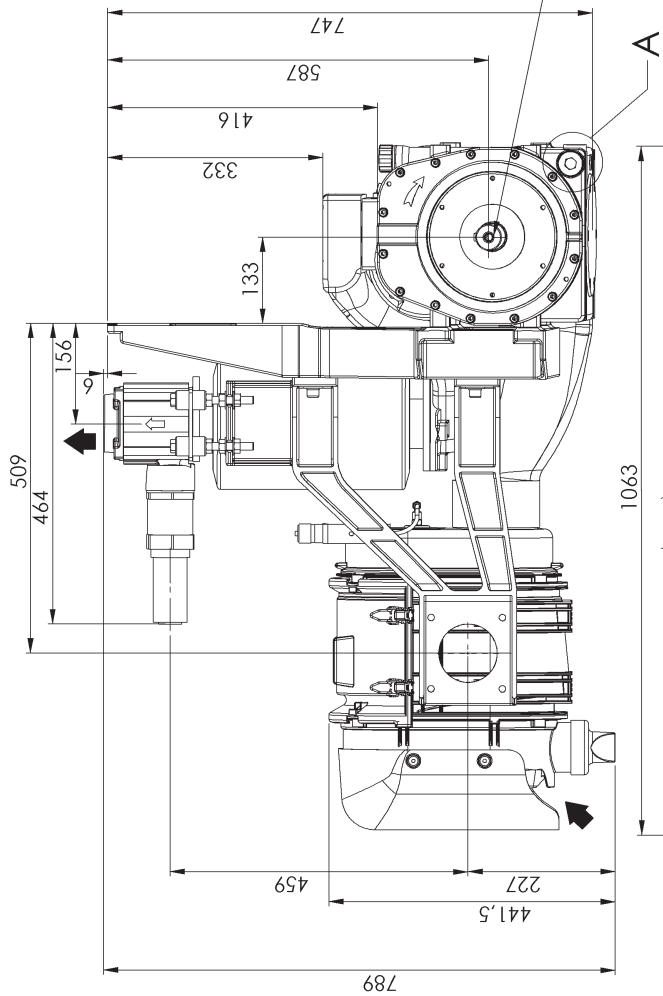
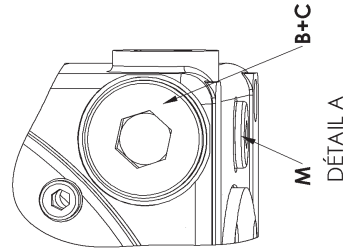

1. OVERALL DIMENSIONS (continued)

MISTRAL 13R/15L - 19R/22L LS-DDNC

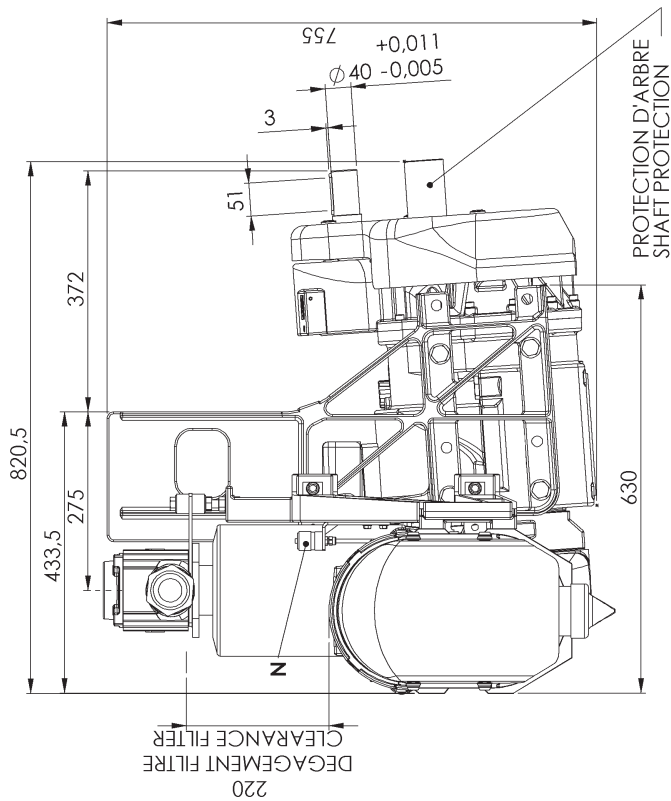

Poids avec limiteur de couple
Weight with torque limiter :
216 kg

A	Jauge d'huile / Oil gauge
B	Filtre à huile / Oil filter
C	Vidange / Draining cap
D	Contrôle pression G1/4" / Pressure control G1/4"
E	Contrôle T° G1/4" / T° control G1/4"
F	Plaque signalétique / Identification plate
G	Prise pression huile / Oil pressure plug
H	Bouchon 3/4" (pour montage jauge d'huile à droite) / 3/4" cap for right oil gauge installation
M	Bouchon magnétique G3/8" / Magnetic plug G3/8"
N	Indicateur de colmatage / Restriction indicator

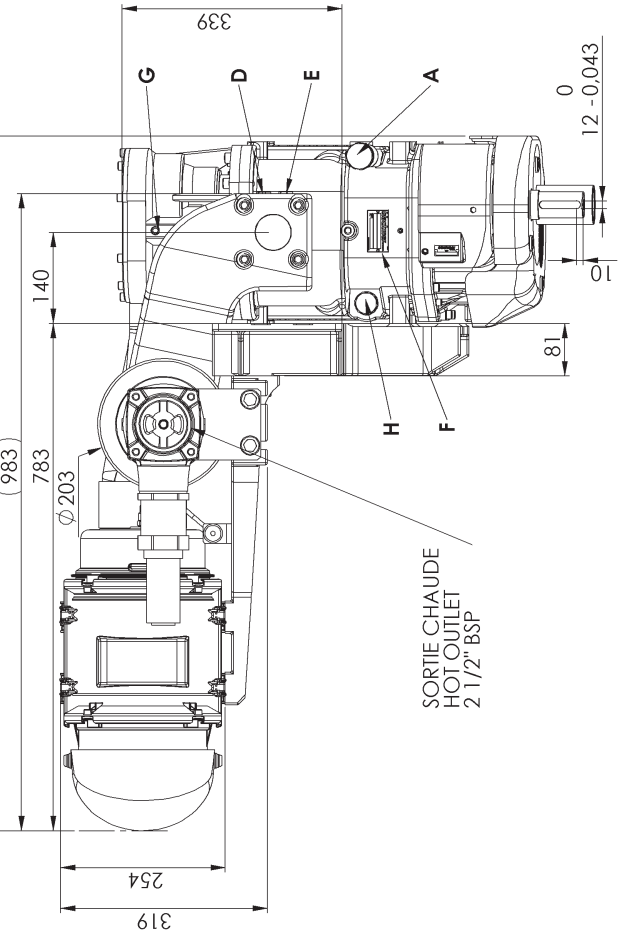
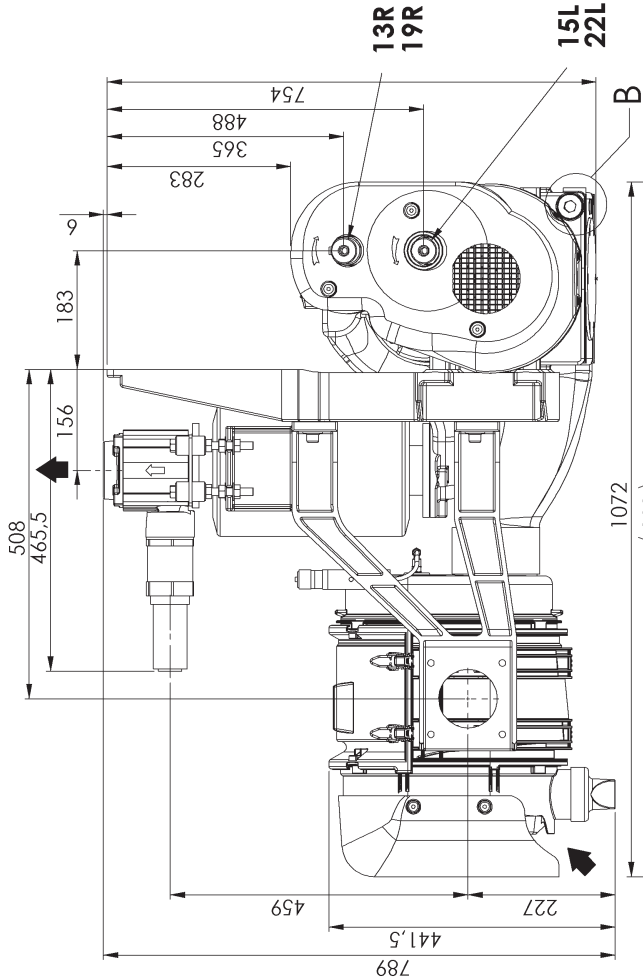
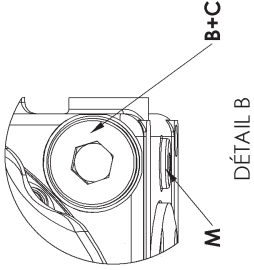

1. OVERALL DIMENSIONS (continued)

TYPHON II 20R - 30R LS-DDNC

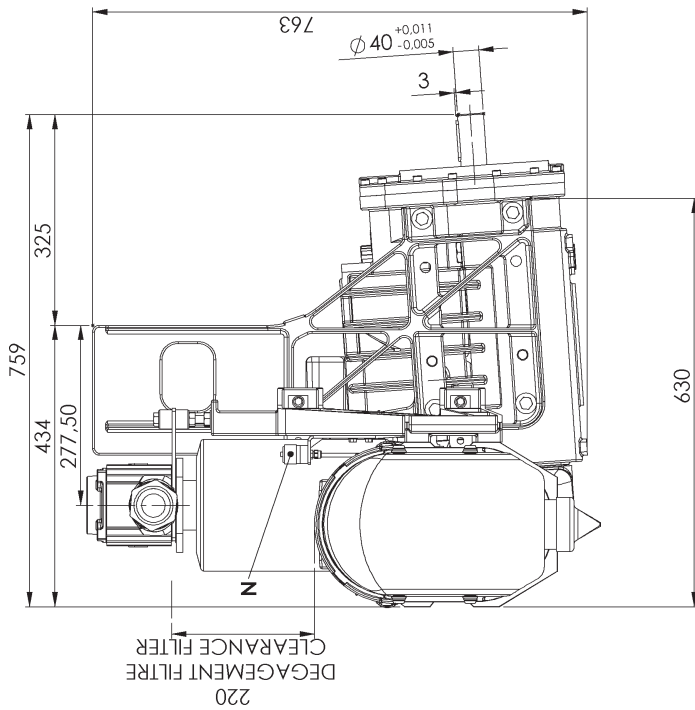

Poids avec limiteur de couple
Weight with torque limiter :
214 kg

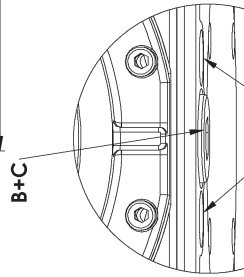

A	Jauge d'huile / Oil gauge
B	Filtere à huile / Oil filter
C	Vidange / Draining cap
D	Contrôle pression G1/4" / Pressure control G1/4"
E	Contrôle T° G1/4" / T° control G1/4"
F	Plaque signalétique / Identification plate
G	Prise pression huile / Oil pressure plug
H	Bouchon 3/4" (pour montage jauge d'huile à droite) / 3/4" cap for right oil gauge installation
J	Prise vitesse G1/4" / Speed control G1/4"
M	Bouchon magnétique G3/8" / Magnetic plug G3/8"
N	Indicateur de colmatage / Restriction indicator

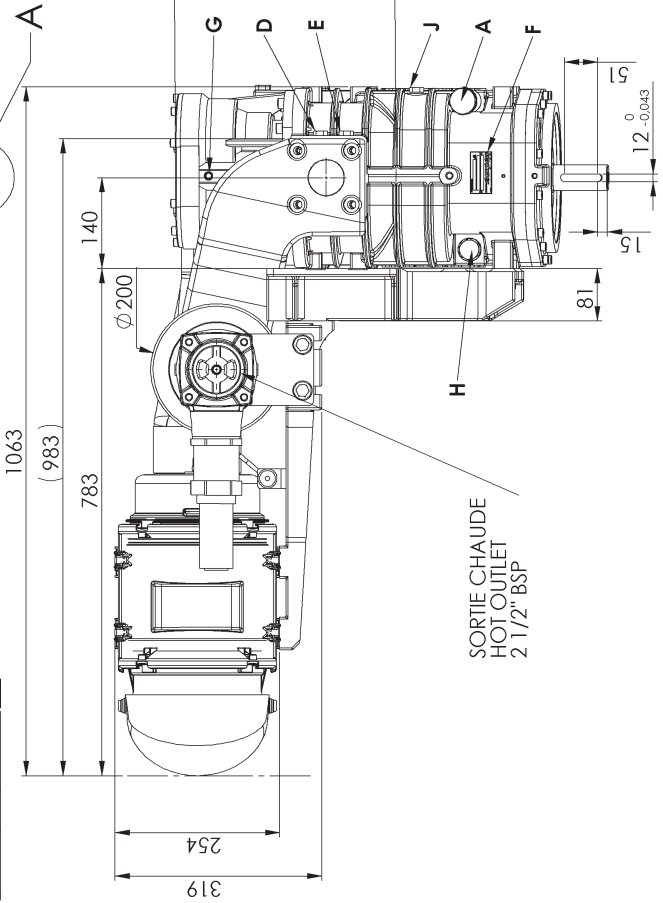
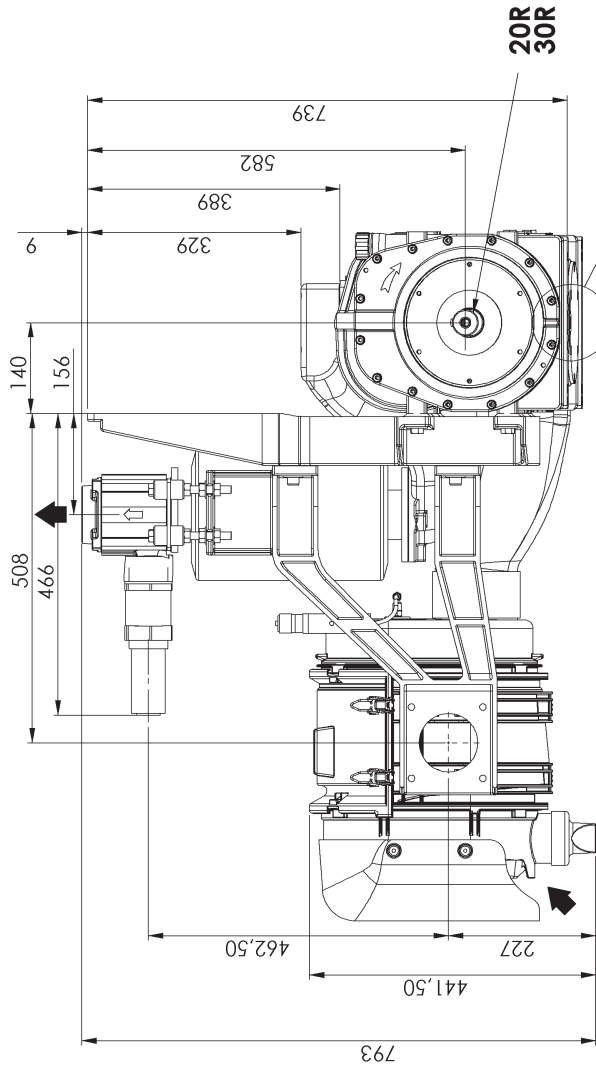

1. OVERALL DIMENSIONS (continued)

TYPHON II 13R/15L - 19R/22L LS-DDNC

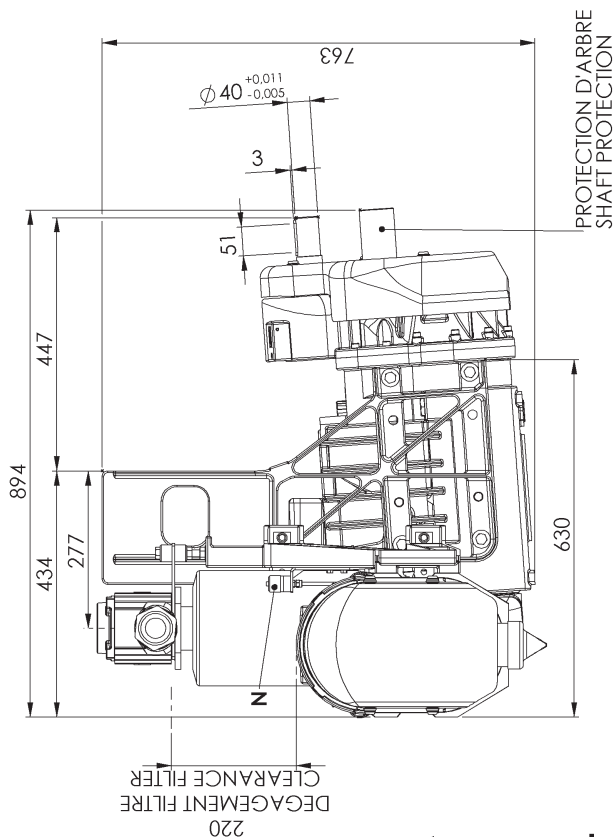

**13R
19R**

**15L
22L**

Poids avec limiteur de couple
Weight with torque limiter :
244 kg

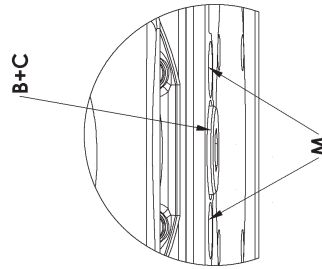

A	Jauge d'huile / Oil gauge
B	Filtre à huile / Oil filter
C	Vidange / Draining cap
D	Contrôle pression G1/4" / Pressure control G1/4"
E	Contrôle T° G1/4" / T° control G1/4"
F	Plaque signalétique / Identification plate
G	Prise pression huile / Oil pressure plug
H	Bouchon 3/4" (pour montage jauge d'huile à droite) / 3/4" cap for right oil gauge installation
J	Prise vitesse G1/4" / Speed control G1/4"
M	Bouchon magnétique G3/8" / Magnetic plug G3/8"
N	Indicateur de colmatage / Restriction indicator

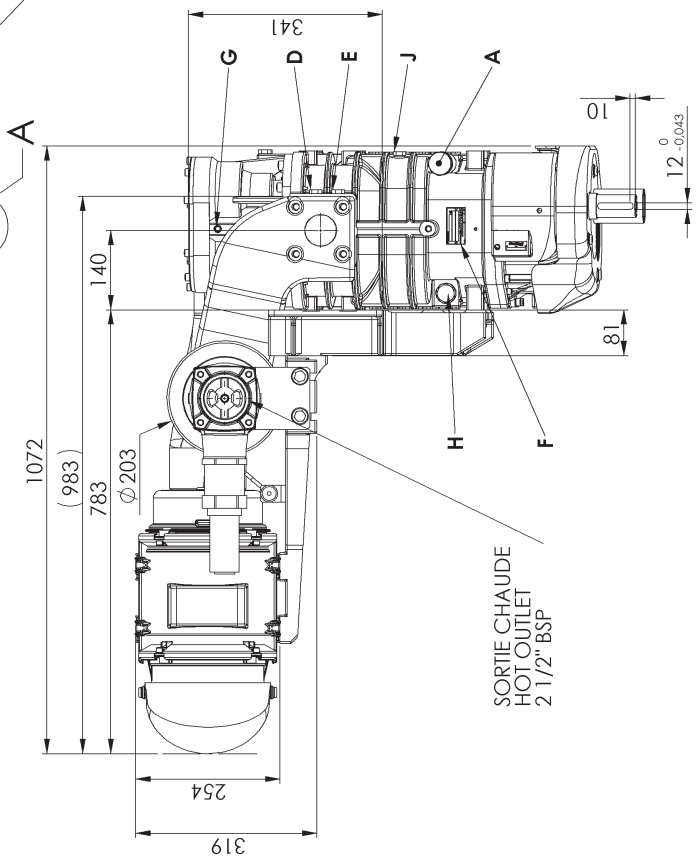
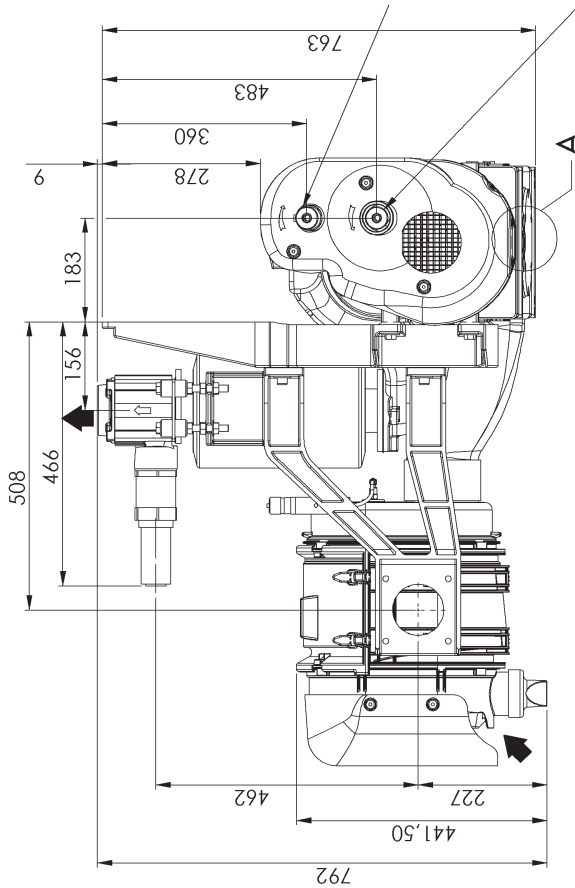

SORTIE CHAUDE
HOT OUTLET
2 1/2" BSP

2. INSTALLATION

The screws used to hold the compressor in place must be at least quality 12-9.

During the assembly, watch that no foreign body penetrates into the compressor. The piping of inhalation and expulsion must be perfectly clean. Any foreign body risks to damage seriously the compressor.

CAUTION

The presence of foreign bodies in the compressor inlet channel is susceptible of leading to serious property damage or serious injuries.

2.1 Mounting location

The compressor must be installed in a location where it is easily accessible. In particular, make sure that the oil filling plug, oil magnetic plugs and the filter are accessible.

The clogging indicator must remain visible to the operator.

Choose a location where the compressor is relatively protected from gravel projections and road spray as well as exhaust fumes and engine heat.

The compressor is mounted on the chair at an angle of 4°. If the chair is mounted vertically, it can be used to adapt to most movements, in other words those which have a gradient of between 3 and 5° inclusive.

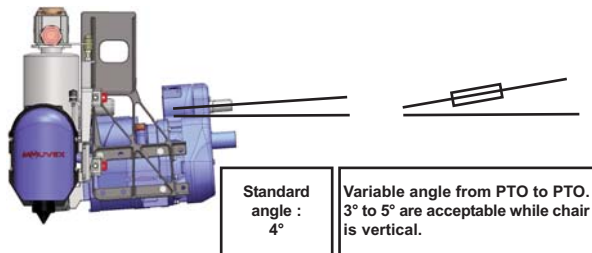

To prevent potential interferences between the package and the truck accessories (mudflap, tank...) a minimum distance of 5 cm between the package and these accessories must be respected.

2.2 Mounting procedure

2.2.1 Package handling procedure

Compressors are packaged and fixed onto a pallet. To move and install the package for the first time, the package should be carried on the pallet.

For maintenance operations, the package should be fastened onto a pallet such that the chair is vertical. The areas set aside for fastening the package are the compressor and the chair, as shown in the picture below.

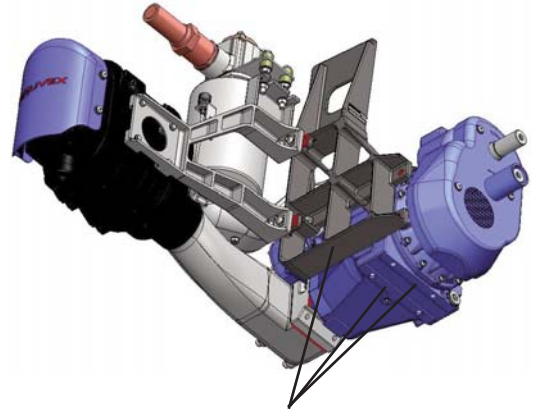

Those areas are acceptable to support the package. Compressor and chair support should be favored.

2.2.2 Package installation procedure

The compressor package is delivered in option with two U profiles mounting brackets. The U are not equal, so that the installer has more room to move when choosing the vertical position of the package.



We propose the following assembly procedure (without the U) :

- Bring the compressor package to the side of the truck using a transpallet or any other suitable equipment.
- Determine the position of the package on the truck as close as possible to its final position.
- Check the universal joint angles and how parallel the compressor shaft and the PTO shaft are.
- Mark on the chair the positions of the holes necessary for assembly.
- Remove the package from the truck.
- Pierce the chair (and the U), deburr and clean. To make sure that you do not make the part fragile keep a minimum axle spread distance of 40 mm between 2 holes.
- Bring the package to the truck.
- Mount the package (and the U) on the chassis with a minimum of 6 fixing points (M14 quality 12-9).
- Remove the pallet and package.
- Check the universal joint angles and how parallel the compressor shaft and the PTO shaft are.
- Mount the universal joint.
- Perform an operating test on the compressor.
- Check with a manometer the pressure at which the valve starts to open.

2. INSTALLATION (continued)

2.3 At suction

It must be installed in such a way that the temperature of the air sucked in is equivalent to 5°C either side of ambient temperature.

Any side protection barriers must be removed EACH time the compressor is used to allow air to reach the compressor inlet freely, and move around the cooling circuit.

The installer must check whether there are such protective barriers and that they may be manipulated easily by the driver. It may be desirable to install a system preventing the operation of the PTO if the protection is not removed, to guarantee that the compressor operates under satisfactory conditions.

To prevent the filters from clogging prematurely, the air sucked in must be free of smoke and road dust.

A minimum distance of 300 mm must be left free in front of the filters for their extraction and replacement.

2.4 Safety valve / Check relief

LS-DDNC packages include a safety valve and a check valve.

See Instructions 1401-E00 SCREW COMPRESSOR CHECK AND RELIEF VALVE.

In the Low Space package case, connexion pressure drop has to be considered.

The 2 possible setting values are :

- 2 bar (2,3 bar at the compressor)
- 2,3 bar (2,5 bar at the compressor).

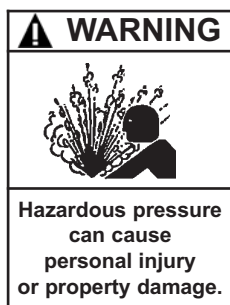

The maximum valve setting is 2,3 bar, but it must take into account the rotating speed range specified in the compressor instructions.

2.5 Drive

2.5.1 Speed range

In order to comply with the machine directive, the rotating parts of the compressor package (shafts, torque limiter, universal joint, PTO ...) must not be accessible to the user or the driver under normal conditions. If necessary, it is the installer's responsibility to fit the necessary protection for preventing any damage to equipment or physical injury.

MOUVEX cannot be held responsible for consequences due to the absence of such protection on the final installation.

The compressor may be operated directly by a universal joint shaft, with or without a multiplier.

The selection of the drive mode will take into account :

- The compressor mounting configuration
- The driving shaft rotation direction
- The expected power requirement for the given application
- The acceptable rpm range for the driving equipment
- The acceptable rpm range for the compressor.



The use of compressors outside of their operating speed range can lead to property damage or serious injuries. See Compressor instructions for more details.

IMPORTANT :

Any system providing for a compressor being driven by a thermal motor must include a system making it possible to disengage the compressor at startup and stop of the motor.

In all cases, the drive must make it possible :

- To maintain the compressor rotation speed during load variations (pressure variations) .
- Not to subject the compressor to sudden or insufficient starts.

2.5.2 PTO shaft drive

It is mandatory to comply with the following instructions :

- The shaft must be dynamically balanced.
- Its length and its inclination must be as small as possible, see table
- The drive shaft slides perfectly well during rotation.
- The jaws of the universal joints are parallel.
- Coupling flanges show no eccentricity nor warping of the bearing surface.
- The angle formed by the universal joint and the drive shaft must not exceed 15°.
- The compressor shaft must be parallel to that of the drive shaft.
- The universal joint angle, as defined below, must be minimised.

2. INSTALLATION (continued)

LS-DDNC packages incorporate a compressor gradient of 4° in relation to the horizontal. This gradient allows the recovery of the most recent PTO angles on current trucks. If your PTO angle is between 3 and 5° inclusive, you can install the chair vertically and respect operating recommendations.

If this is not the case, you should gently slope the chair to bring the angle between the compressor operating shaft and the PTO below 1°.

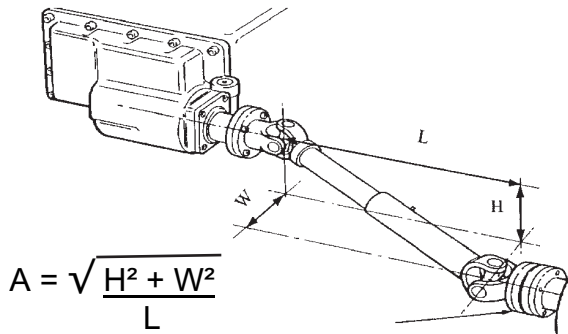

A	Universal joint angle	
0,017	1°	VERY GOOD
0,035	2°	
0,052	3°	
0,070	4°	
0,087	5°	
0,105	6°	GOOD
0,125	7°	
0,141	8°	
0,158	9°	
0,176	10°	LIMIT VALUES
0,194	11°	
0,213	12°	
0,231	13°	
0,249	14°	
0,268	15°	

It is possible to equip packages with a multiplier to lessen the universal joint angle. Refer to the compressor instructions for further information.

To protect the P.T.O in the event of compressor stalling, **it is necessary to install a torque limiter.** The MOUVEX company shall not be held responsible for damage resulting from such stalling if this stalling is caused by wrong manipulation with the compressor or if no or not the right torque limiter is installed.

The torque limiter will be installed on the compressor shaft, as illustrated in the photo below.

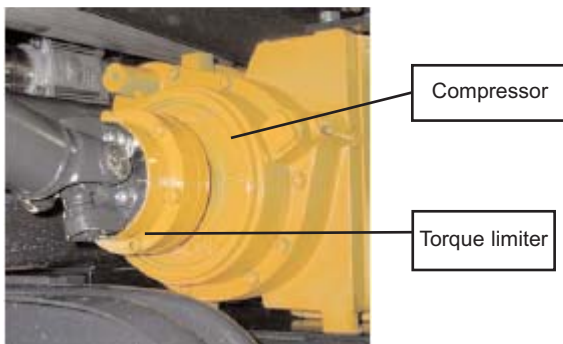

LS-DDNC packages may be ordered with torque limiters mounted. Refer to Instructions 1401-B00 TORQUE LIMITER - SCREW COMPRESSORS.

CAUTION

If the greasing instructions for the universal joint are not respected, this can lead to ruptures of this universal joint, as well as property damage and serious injuries.

2.5.3 Installation of channelling

Channelling connected to the package must be designed in accordance with regulations to prevent premature breakdowns on the installation.

In particular, MOUVEX recommends taking the following precautions:

- Channelling must be supported so as to prevent them from mechanically loading the inlets and outlets on the compressor package.
- Discharge channelling must have a diameter at least equal to that of discharge connections on the compressor package.

2.6 Instrumentation

The package is supplied with an inlet filter clogging indicator.

Any use of the compressor package when the indicator is showing excessive clogging will cause damage to equipment or physical injury.

Once the filters have been replaced, the clogging indicator may be reset to zero merely by rotating its cap.

2.7 Chair modification

The chair must not be modified except the following operations :

- Fixation holes as described above,
- Using of the fixation lines the most distant (L),
- Shortening allowed by taking care of the dimensions of 5 mm

risk of loss of MOUVEX warranty on the equipment.

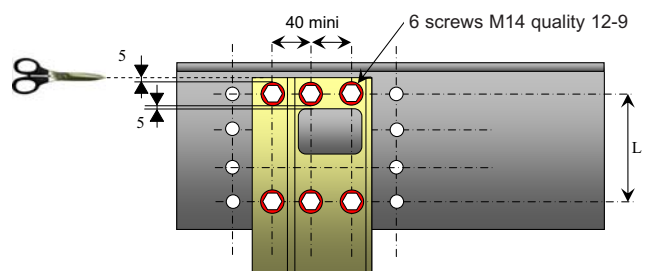

3. MAINTENANCE

3.1 Maintenance schedules

See the compressor instructions for the maintenance programme.

3.2 Air filter replacement procedure

Check weekly the clogging indicator. When it turns red, replace the filter cartridge.

Before installing a new cartridge, clean the internal part of the filter housing with a clean damp cloth.



The presence of foreign bodies in the compressor inlet channel is susceptible of leading to serious property damage or serious injuries.

3.3 Cartridge replacement procedure

- Untight the 4 latches **4** holding the filter cover **1**.
- Remove the filter cover.
- Remove the 2 cartridges (central and security).
- Throw away the old cartridges.
- Clean the area around the cartridge seal with a rag.
- Place the cartridges in the following order :
 - Security cartridge **3**
 - Central cartridge **7**
- Replace the filter cover.
- Tight the 4 latches **4**.

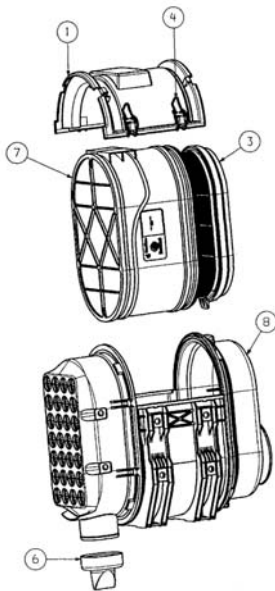

3.4 Drive train inspection

Periodically check that there is no play in the jaws and PTO cross pieces, turning the universal joint manually in one direction then in the other direction.

3.5 Check valve and relief valve inspection

See Instructions 1401-E00 SCREW COMPRESSOR CHECK AND RELIEF VALVE.

3.6 Warranty claims

The following part are considered as wear part :

- Inlet filter cartridge
- Compressor oil

No failure connected with wear part damage will be accepted under warranty conditions.

The following situations will void warranty for all components of the package :

- Tampering with the setting of the relief valve.
- Presence of foreign material inside the compressor body.
- Traces of damage representative of abnormal use of the package.
- Use of non genuine parts.
- If the compressor is repaired by a repairer who is not a MOUVEX-approved repairer.
- Construction of the package not validated by our Design Office.
- Use of an oil other than BSC for a 13R/15L and 19R/22L compressor.

Before returning your equipment to the factory, you must first obtain an Equipment return approval (RMA) from our After Sales Department.

A Compressors form information shall be filled by the installer or distributor and send to MOUVEX in order to claim for a warranty.

4. TROUBLESHOOTING

CAUTION :
OBSERVE ALL SAFETY WARNINGS CONTAINED IN THIS MANUAL.

Problem	Possible origin	Possible solution
1. Pressure issue	Too much pressure drop.	To check pipes diameter.
	Relief valve damaged.	To check the opening point.
	No return valve damaged.	To check the proper operating of the No return valve.
2. Flow rate issue	Wrong Compressor speed.	To adjust the speed by taking care of the range allowed.
	Relief valve damaged.	To check the opening point.
3. Abnormal high temperature	Air filter clogged.	To clean the cartridge or to replace it.
	Air pressure too much high.	To see problems 1. / 2.
	Outside temperature too much high.	To respect the maximum external temperature allowed.
	Lack of oil.	To check the oil level.
	Compressor speed too much low.	To adjust the speed by taking care of the range allowed.
4. Inlet pressure drop > 75 mbar (Clogging indicator red)	Air filter clogged.	To clean the cartridge or to replace it.
	Air inlet hose folded.	To check the air inlet hose.
5. Compressor doesn't operate	Torque limiter damaged.	To replace the torque limiter.
	Transmission damaged.	To consult your Service point.
6. Torque limiter damaged	Screw Compressor damaged.	To consult your Service point.
	Clutch operates too much fast.	To consult your Truck dealer.
	Oil too much viscous.	To be in compliance with the MOUVEX Instructions.
7. Oil leak	Too much oil.	To check the oil level.
	Oil breather clogged.	To clean the oil breather.
8. Vibrations	Wrong motor speed.	To increase the speed by taking care of the range allowed.
	Transmission damaged.	To check the driving shaft.
	Lack of rigidity of the chassis.	To be in compliance with the Truck Manufacturer Instructions.

5. STORAGE CONDITIONS

The equipment must be systematically stored in an area sheltered from bad weather.

If installation is interrupted, put back in place the original protective components or equivalent components.

The equipment must bear its original protective components until it is installed in its final application.

6. USE

The operator should remain nearby the equipment throughout the use to ensure the proper functioning of the system.

7. SCRAPPING

The compressor must be scrapped in compliance with the regulations in force.

During this operation, particular care must be paid to the drainage stages of the compressor.

8. COMPRESSORS FORM INFORMATION

Before any material return, it is required to get an authorization from MOUVEX.

	COMPRESSORS FORM INFORMATION	FORM RMA / YY / NNN SAV-002-11.2011
MOUVEX After Sales Department Z.I. La Plaine des Isles 89000 AUXERRE - FRANCE	Tel : (33) 3 86 49 86 03 Fax : (33) 3 86 49 86 48	Date : Followed by : File :
In order to properly deal with the return material, please fill in this form.		
A – Name and address of user _____ _____ <input type="checkbox"/> Person to contact : _____ Phone Nr : _____		
B – Name and address of installator _____ _____ <input type="checkbox"/> Person to contact : _____ Phone Nr : _____		
C - Material's serial number _____ D - Starting up date _____ <input type="checkbox"/> Running time estimation _____		
E - Installation details	F - Operating parameters	
<input type="checkbox"/> PTO flanged <input type="checkbox"/> Propshaft drive system (direct PTO drive) <input type="checkbox"/> 30R <input type="checkbox"/> 20R <input type="checkbox"/> 19R <input type="checkbox"/> 13R <input type="checkbox"/> 22L <input type="checkbox"/> 15L <input type="checkbox"/> 12R <input type="checkbox"/> 10L <input type="checkbox"/> Torque limiter <input type="checkbox"/> Pressure relief valve setting (value) _____ <input type="checkbox"/> Belt drive system <input type="checkbox"/> Package air cooler <input type="checkbox"/> Package RTI <input type="checkbox"/> Other (electric, thermic or hydraulic motor) _____ _____ _____ _____	<input type="checkbox"/> Compressor's speed _____ <input type="checkbox"/> Operating pressure _____ <input type="checkbox"/> Motor speed (tachometer) at the time of the incident _____ <input type="checkbox"/> PTO ratio : _____ <input type="checkbox"/> Product transfered _____ _____ _____	
	G - Suction conditions	
	<input type="checkbox"/> Air connection on truck chimney <input type="checkbox"/> Direct air connection <input type="checkbox"/> Flexible pipe between filter and compressor <input type="checkbox"/> Inox pipe between filter and compressor	
H - DESCRIPTION OF THE FAILURE		
<input type="checkbox"/> Blocking <input type="checkbox"/> Leakage <input type="checkbox"/> Noise, vibration <input type="checkbox"/> Other _____ _____ _____ _____		
I - Has the machine been replaced by a new one ? If yes which is the serial number _____ J - Has the machine been replaced by a removed one ? If yes which is the serial number _____		
K - Remarks and comments of the user about the problem :		
_____ _____ _____ _____		
Please send us back this completed form by fax or E mail as quick as possible.		

9. CERTIFICATE OF CONFORMITY



CERTIFICATE OF CONFORMITY CE

MOUVEX, Z.I. La Plaine des Isles - Rue des Caillottes - 89000 AUXERRE FRANCE, declares the following equipment :

Set-up : Pump / Compressor « bare-shaft » Pumping Unit / Compressor Unit
Type : Eccentric Disc Pump Vanes Pump Lobes Pump
 Peristaltic Pump Centrifugal Pump Other Pump
 Screws compressor Vanes compressor Hydraulic cooler

Designation : _____ s/n° : _____

According to the specifications recorded in the file N° : _____

is in conformity with the provisions of the following Directive :

- « **MACHINES** » Directive 2006/42/EEC as transposed by the national legislation, concerning safety equipments and arrangements relative to mechanical and electric risks applicable to rotative machines.
NF EN 809:2009 NF EN 1672-2:2009 NF EN ISO 13857:2008 NF EN 12162:2009

And with the following marking :  II2 G c IIB-T4 Max T° Flow = 80°C

is in conformity with the provisions of the following Directive :

- « **ATEX** » Directive 94/9/EC (23 march 1994) as transposed by the national legislation, concerning equipment intended to be used in explosive atmospheres. Conformity obtained by application of the standards :
NF EN 1127-1:1997 NF EN 13463-1:2009 NF EN 13463-5:2009

ATEX Certification delivered by INERIS, Notified Body (INERIS - Parc Technologique Alata - 60550 Verneuil-en-Halatte - France).

The equipment indicated above must be used according to the foreseen use by its design and its manufacturing, and according to the current standards.

We, undersigned, declare that the concerned equipment is in conformity with the Directives listed above and in the applicable standards in force.

For MOUVEX SAS Company.
Date : _____



Quality Manager

MOUVEX sas : Z.I. La Plaine des Isles - 2, rue des Caillottes - 89000 AUXERRE - France - SAS au capital de 8 496 855 €
Tél : (33) 3.86.49.86.30 - Fax : (33) 3.86.46.42.10 - RCS AUXERRE 389 236 548 - APE 291 B - FR 85 389 236 548
www.mouvex.com