

(See Instructions 1003-J00 for Installation, Operation and Maintenance)

Section	1003
Effective	November 2011
Replaces	September 2011

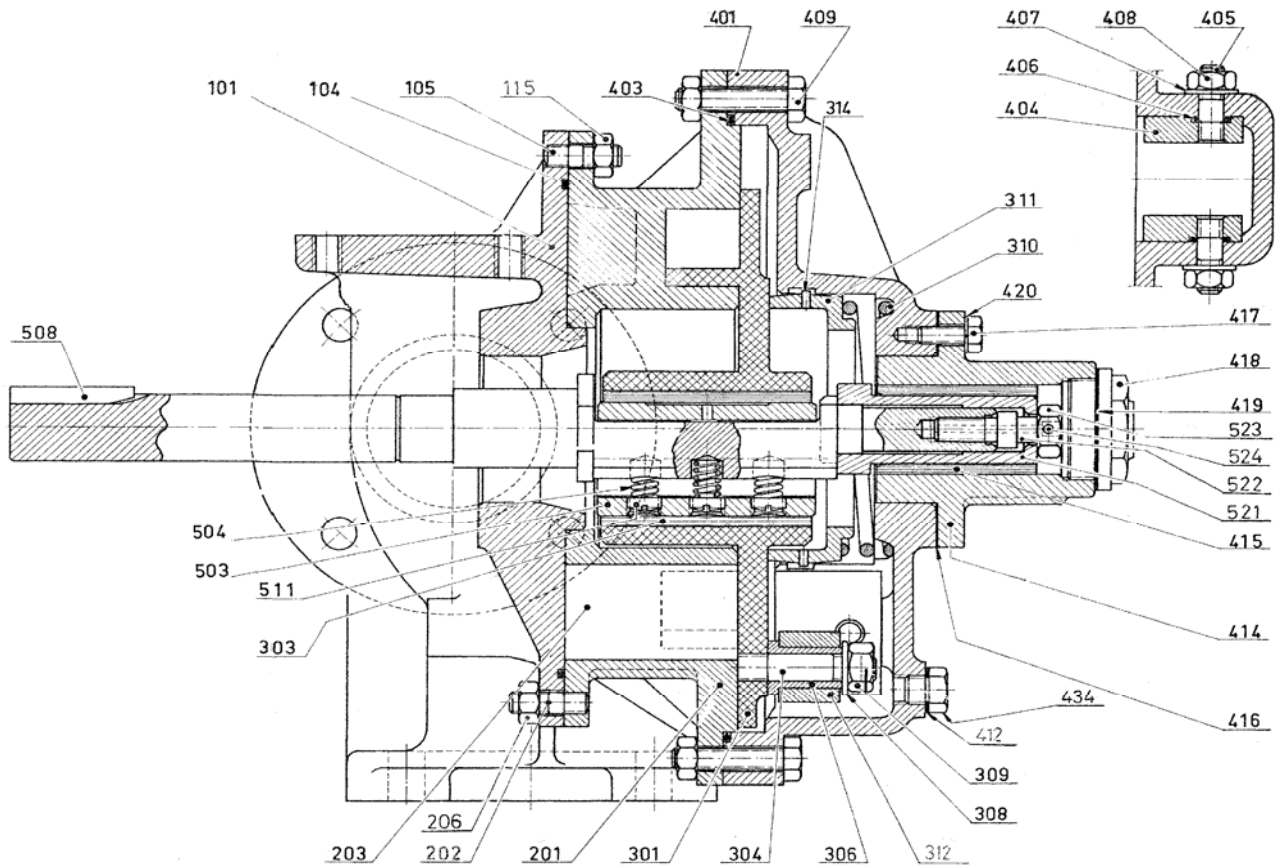

Reference			Description	Quantity		Article code	Wear parts	
Ass.	Part	Available		Order	In Pump	AL O HP		
98		◆	Full set of screws	1		300610.00		
			Stud					(5)
			Nut					(5)
			Stud					(5)
			Nut					(5)
			Screw					(8)
			Nut					(8)
			Screw					(4)
			Washer					(4)
			98					
	105		Stud	(5)				
	115		Nut	(5)				
	202		Stud	(5)				
	206		Nut	(5)				
	409		Screw	(7)				
	409a		Nut	(7)				
	417		Screw	(4)				
	420		Washer	(4)				
	424		Stud	(1)				
	436		Gasket	(1)				
99		◆	Full set of seals - FKM	1		300601.00		
99		◆	Full set of seals - FKM (Heating jacket)	1		304057.00		
	104		Gasket	(1)				
	403		Front cover seal	(1)				
	406		Seal	(2)				
	416		Gasket	(1)				
	419		Seal	(1)				
	1002		Seal	(1)				

(◆) Sets of parts or (▲) parts available to order.

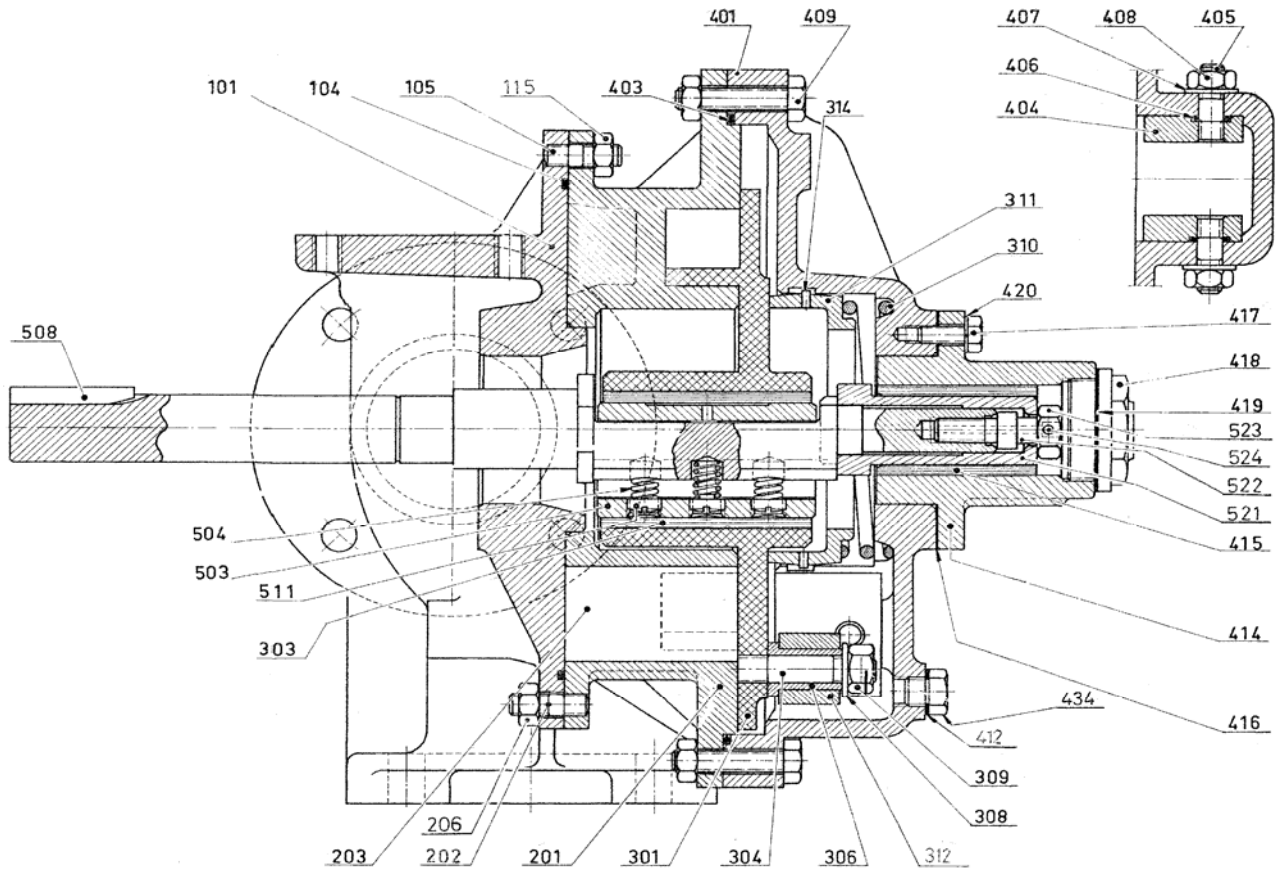

Reference			Description	Quantity		Article code	Wear parts	
Ass.	Part	Available		Order	In Pump	AL O HP		
100		◆	Main body, complete	1		300591.00		
		101	Main body		(1)			
		105	Stud		(5)			
		115	Nut		(5)			
		817	◆	Mounting kit	1		300693.00	
		813	Nut		(2)			
		814	Stud		(2)			
	815	Washer		(2)				
200		◆	Cylinder, complete	1		301747.00	•	
		201	Cylinder		(1)			
		202	Stud		(5)			
		203	▲	Bulkhead	1		201597	
	206		Nut		(5)			
300		◆	Complete piston - Bronze bushing	1		301748.00	•	
		◆	Complete piston - Carbonbushing	1		309176.00	•	
		◆	Complete piston (drilled) - Bronze bushing	1		311182.00	•	
		◆	Complete piston (drilled) - Carbon bushing	1		311191.00	•	
		3010		Piston + Block pin		(1)		
		303	▲	Piston bushing (bronze)	1		203595	•
		303	▲	Piston bushing (carbon)	1		211657	•
		315		Screw (for drilled piston)		(1)		
		398	◆	Slide block, complete	1		305224.00	
		308		Washer		(1)		
		309		Nut		(1)		
		307	◆	Slide block + bushing	1		300694.00	•
	306		Bushing		(1)			
	312		Slide block		(1)			
399		◆	Guide block, complete	1		300595.00		
		310	Spring		(1)			
		311	Piston rear spring seat		(1)			
	314		Pin		(2)			

(◆) Sets of parts or (▲) parts available to order.

Reference			Description	Quantity		Article code	Wear parts
Ass.	Part	Available		Order	In Pump	AL O HP	
400		◆	Complete front cover - FKM	1		301751.00	
460		◆	Complete front cover with jacket	1		311407.01	
	401		Front cover		(1)		
	461		Jacketed front cover		(1)		
	462		Jacket drain plug		(2)		
	402	◆	Front bushing set - FKM	1		300603.00	•
	402	◆	Front bushing set - Teflon encapsulated FKM	1		300608.04	•
	404		Guide		(2)		
	405		Stud		(2)		
	406		Seal		(2)		
	407		Washer		(2)		
	408		Nut		(2)		
	411	◆	Front cover drain plug + seal	1		300036.00	
	412		Seal		(1)		
	434		Drain plug		(1)		
	403	▲	Front cover seal - FKM	1		200840	
413		◆	Front cover bearing complete - Bronze bushing	1		300597.00	
413		◆	Front cover bearing complete - Carbon bushing	1		307654.00	
	414		Front cover bearing		(1)		
	415	▲	Bearing bushing - Bronze	1		201615	•
	415	▲	Bearing bushing - Carbon	1		211658	•
	416		Gasket		(1)		
	417		Screw		(4)		
	418		Plug		(1)		
	419		Seal		(1)		
	420		Washer		(4)		
500		◆	Shaft Blocdir complete	1		312274.00	
	505	▲	Shaft	1		219469	
	503	▲	Piston bearing	1		203600	•
	508	▲	Key	1		211035	
	598	◆	Bearing spring complete	1		300598.00	
	504		Spring		(3)		
	511		Screw		(3)		
	515	◆	Complete sleeve	1		300716.00	•
	521		Sleeve		(1)		
	522		Screw		(1)		
	523		Nut		(1)		
	524		Pin		(1)		

(◆) Sets of parts or (▲) parts available to order.

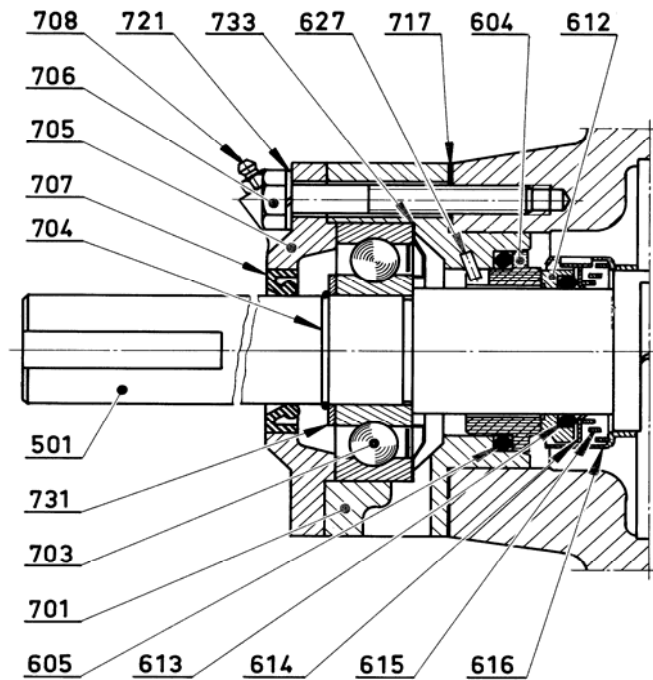

Reference			Description	Quantity		Article code	Wear parts
Ass.	Part	Available		Order	In Pump	AL O HP	
600		◆	Mechanical seal - Blocdir C/I VT	1		300639.00	•
600		◆	Mechanical seal - Blocdir C/I CVT	1		307549.00	•
600		◆	Mechanical seal - Blocdir HR VT	1		303333.00	•
600		◆	Mechanical seal - Blocdir HR CVT	1		307550.00	•
	610		Stationary seal face complete - Blocdir		(1)		
	604		Stationary seal face		(1)		
	605		Seal		(1)		
	697		Rotating part - Blocdir		(1)		
	612		Seal housing		(1)		
	613		Seal		(1)		
	614		Spring guide		(1)		
	615		Spring		(1)		
	616		Cage		(1)		
	619		Seal mounting tool (for CVT)		(1)		
700		◆	Ball bearings complete	1		300631.00	
	627	▲	Pin	1		200139	
	701		Bearing cage		(1)		
	703	▲	Ball bearing	1		200555	•
	705		Bearing cover		(1)		
	706		Screw		(4)		
	708		Grease nipple		(1)		
	721		Washer		(4)		
	797	◆	Ball bearing washers and gasket set	1		300719.00	
	704		Ring		(1)		
	707		Lip seal		(1)		
	717		Cage seal		(1)		
	731		Washer		(1)		
	733		Protection circlip		(1)		

CVT : FEP encapsulated FKM

Mechanical seal :

C/I : Carbon/stainless - HR : Tungsten carbide/tungsten carbide

(◆) Sets of parts or (▲) parts available to order.

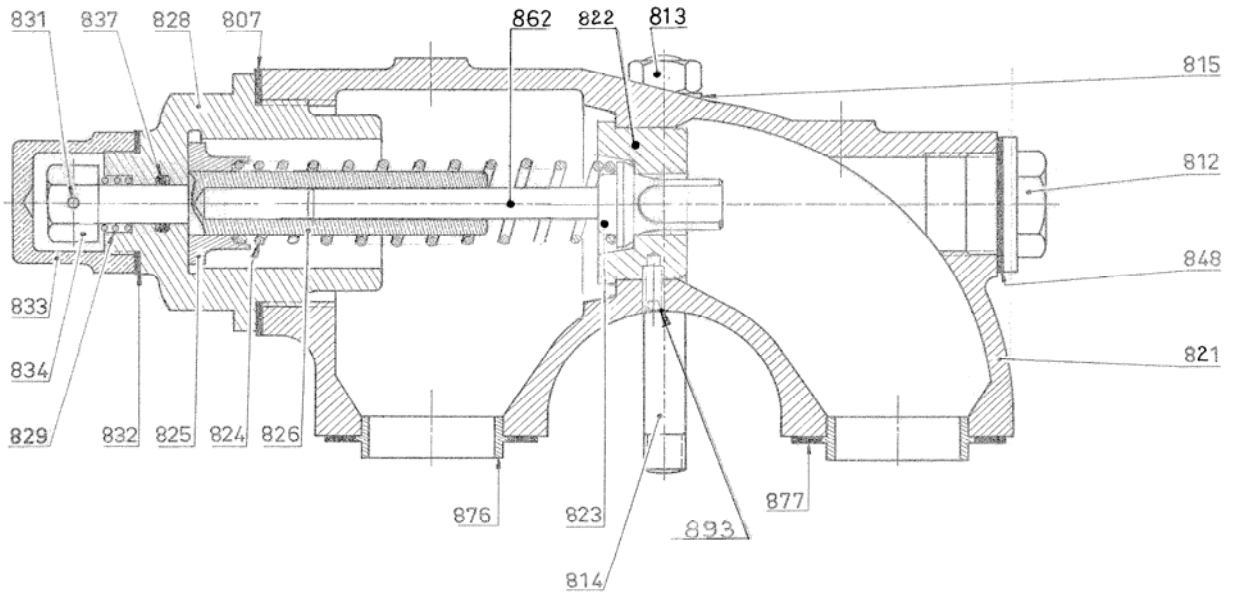

Reference			Description	Quantity		Article code	Wear parts
Ass.	Part	Available		Order	In Pump	AL O HP	
820		◆	Bypass C/2 complete - FKM	1		306248.00	
820		◆	Bypass C/3 complete - FKM	1		306253.00	
	870	◆	Bypass body complete	1		301759.00	
	812		Plug		(1)		
	821		Bypass body		(1)		
	848		Seal		(1)		
	824	▲	Spring n°2	1		201189	
	824	▲	Spring n°3	1		201190	
	869	◆	Bypass cap and gasket	1		300740.00	
	832		Seal		(1)		
	833		Cap		(1)		
	878	◆	Centering set	1		300739.00	
	876		Centering piece		(2)		
	877		Centering gasket		(2)		
	897	◆	Adjusting screw/valve set - FKM	1		306246.00	•
	807		Seal		(1)		
	825		Spring guide		(1)		
	826		Adjusting screw		(1)		
	828		Nut		(1)		
	829		Spring		(1)		
	831		Pin		(1)		
	834		Adjustment nut		(1)		
	837		Seal		(1)		
	864	▲	Valve	1		225721	
	899	◆	Bypass gasket set - FKM	1		300664.00	
	807		Seal		(1)		
	829		Spring		(1)		
	831		Pin		(1)		
	832		Seal		(1)		
	837		Seal		(1)		
	846		Seal		(1)		
	848		Seal		(1)		
	877		Centering gasket		(2)		

(◆) Sets of parts or (▲) parts available to order.

Reference			Description	Quantity		Article code	Wear parts
Ass.	Part	Available		Order	In Pump	AL O HP	
VARIATIONS							
COMPLETE COMPENSATED DOUBLE BYPASS							
The body is different to the standard compensated bypass. The other parts are the same but doubled							
820a		◆	Double bypass C/2 complete - FKM	1		306250.00	
820a		◆	Double bypass C/3 complete - FKM	1		306256.00	
	870a	◆	Double bypass body complete	1		301763.00	
	821a		Double bypass body		(1)		
849		◆	Complete stirrup	1		301649.01	
	852		Stirrup		(1)		
	853		Stud		(2)		
	854		Plug		(2)		
	855		Seal		(2)		
To mount a bypass in place of a stirrup will require :							
	817	◆	Mounting kit	1		300693.00	
	813		Nut		(2)		
	814		Stud		(2)		
	815		Washer		(2)		

(◆) Sets of parts or (▲) parts available to order.

Keep this parts lists with Installation, Operation and Maintenance Instructions.

To order the required spare parts, indicate the appropriate CUM numbers.



Z.I. la Plaine des Isles - 2 rue des Caillottes F-89000 AUXERRE - FRANCE

Tel : +33 (0)3 86 49 86 30 • Fax : +33 (0)3 86 49 87 17

contact@mouvex.com • www.mouvex.com