

**MOUVEX**  
**MODEL :**

**PARTS LIST**  
**CC8-65 A**

<b>PL :</b> 1010-D02	
Section	1010
Effective	September 2011
Replaces	New

(See Instructions 1010-D00 for Installation, Operation and Maintenance)

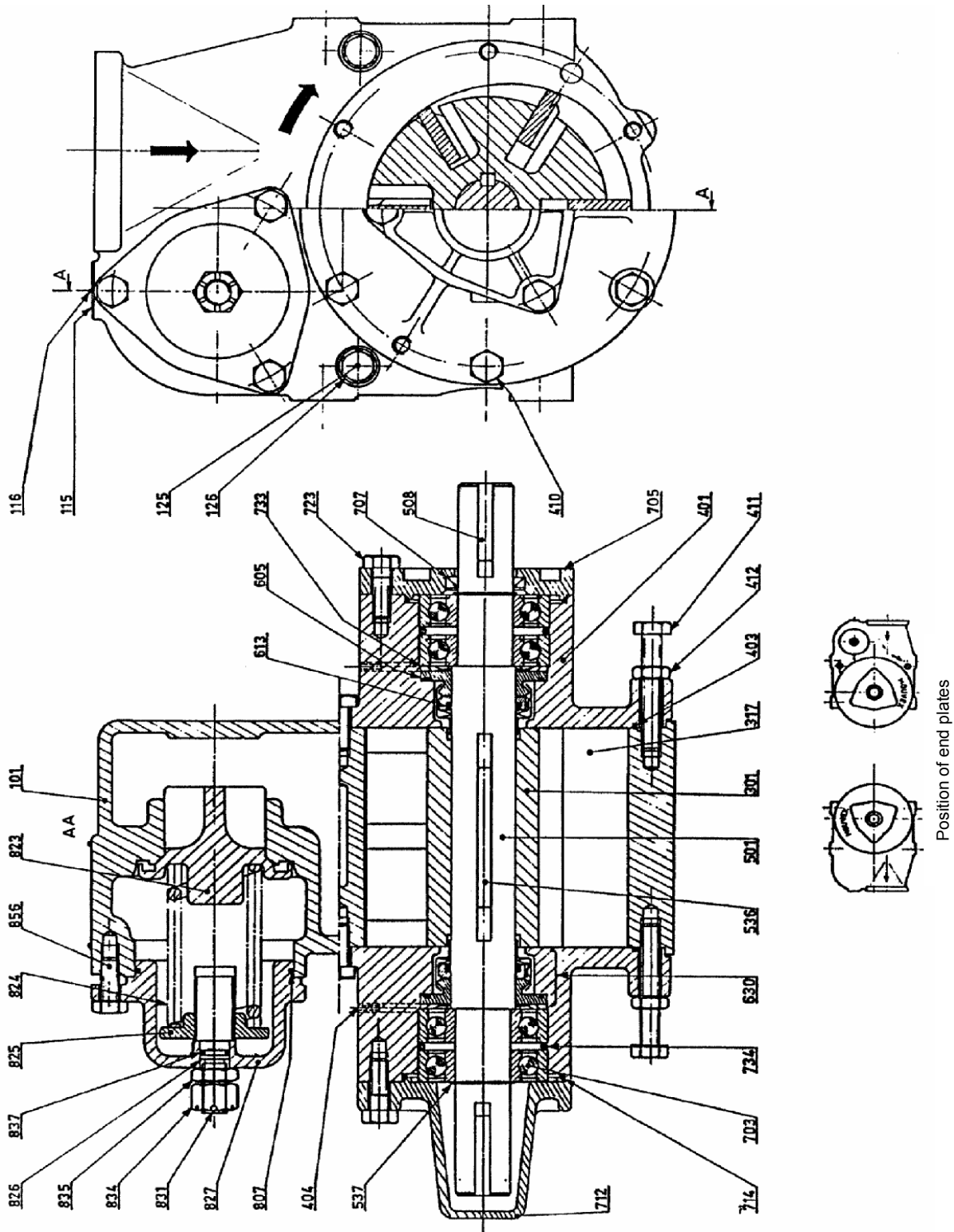

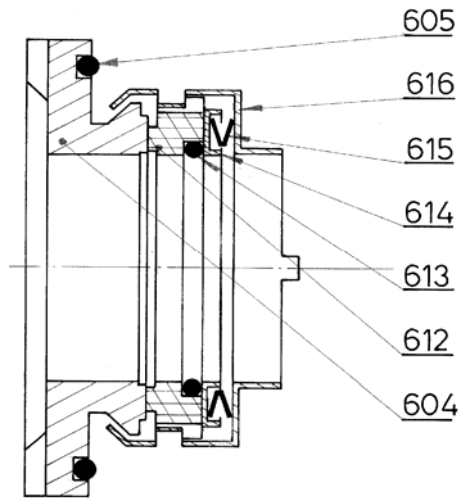

MECHANICAL SEAL ASSEMBLY

Article code	Description	Quantity	Reference	Wear parts	Notes
301865.00	SET OF SCREWS (410+411+412+723+856)	1	98		◆
301914.00	SET OF SEALS (126+403+807)	1	99		◆
301908.00	PUMP CASING ASSEMBLY	1	100		◆
	Casing	1	101		See 100
	Identification plate	1	115		See 100
	Rivet	2	116		See 100
301861.00	Set of plugs and seals	1	124		◆
	Capscrew HM 10 X 16	2	125		See 124
	Plug seal	2	126		See 99
301909.00	ROTOR ASSEMBLY (6 vanes design)	1	300		◆
302475.00	ROTOR ASSEMBLY (6 vanes TR design) ■	1	300		◆
	Rotor	1	301		See 300
	Vane / Vane TR	6	317	X	See 309
304377.00	SET OF VANES (6 vanes design)	1	309		◆
304380.00	SET OF VANES (6 vanes TR design) ■	1	309		◆
	Vane / Vane TR	6	317	X	See 309
301911.00	END PLATE ASSEMBLY	2	400		◆
	End plate	1	401		See 400
	Drip hole	2	404		See 400
	Capscrew HM 10X25	4	410		See 98
	Capscrew HM 10X70	2	411		See 98
	Nut H M10	2	412		See 98
304378.00	SET OF END PLATE O'RINGS ■	1	409		◆
	End plate O'ring	2	403		See 99
301912.02	SHAFT ASSEMBLY	1	500		◆
	Shaft	1	501		See 500
301913.00	Set of keys ■	1	599		◆
	Shaft key	1	508		See 599
	Rotor key	1	536		See 599
	Circlips	2	537		See 599
311700.04	MECHANICAL SEAL ASSEMBLY KIT ■	0	630A	X	◆
301916.00	MECHANICAL SEAL ASSEMBLY	1	630		◆
	Stationary seal	1	604		See 630
	Stationary seal O'ring	1	605		See 699
	Rotating seal	1	612		See 630
	Rotating seal O'ring	1	613		See 699
	Spring guide	1	614		See 630
	Spring	3	615		See 630
	Retainer shaft seal	1	616		See 630
	Control disc (not shown)	1	630B		See 630
301918.00	SET OF MECHANICAL SEAL O'RINGS (605+613)	2	699		◆

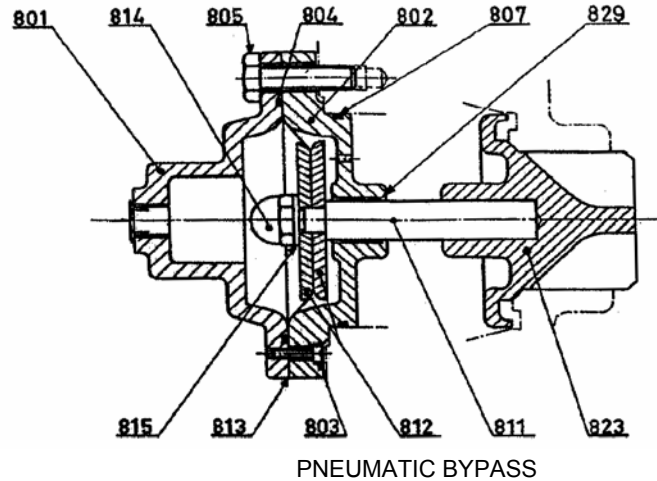

Article code	Description	Quantity	Reference	Wear parts	Notes
<b>304712.00</b>	<b>BEARING ASSEMBLY (no driving end)</b>	<b>1</b>	<b>700</b>		◆
	Ball bearing	2	703		See 704
	Bearing cover	1	712		See 700
	Bearing cover O'ring	1	714		See 700
	Capscrew HM 10X30	3	723		See 98
	Metallic seal	1	733		See 715
	Ring	1	734		See 700
<b>304713.00</b>	<b>BEARING ASSEMBLY (driving end)</b>	<b>1</b>	<b>700A</b>		◆
	Ball bearing	2	703		See 704
	Bearing cover	1	705		See 700A
	Lip seal	1	707	X	See 715
	Bearing cover O'ring	1	714		See 715
	Capscrew HM 10 X 30	3	723		See 98
	Metallic seal	1	733		See 715
	Ring	1	734		See 700A
<b>304379.00</b>	<b>SET OF BALL BEARINGS ■</b>	<b>1</b>	<b>704</b>		◆
	Ball bearing	4	703		See 704
	Grease nipple plug (Screw HC M8 X 8)	4	708		See 704
<b>304722.00</b>	<b>SET OF COVER SEALS (707+714+733) ■</b>	<b>1</b>	<b>715</b>		◆
<b>304567.03</b>	<b>PNEUMATIC BYPASS</b>	<b>1</b>	<b>800</b>		◆
	Bypass cap	1	801		See 800
	Bypass base	1	802		See 800
	Screw CS M4X20	2	803		See 800
	O'ring	1	804		See 816
	Screw HM 10X45	3	805		See 800
	Base O'ring	1	807		See 816, 99
301898.03	Membrane assembly	1	810		◆
	Pushrod	1	811		See 810
	Membrane disc	2	812		See 810
204848	Membrane ■	1	813	X	▲
	Blind nut M10	1	814		See 810
	Seal	1	815		See 810
218445	Valve	1	823		▲
	Bearing	1	829		See 800
303353.00	Pneumatic pressure limiter 5,5 bar (not shown)	1	930		◆
<b>301899.00</b>	<b>PNEUMATIC BYPASS O'RINGS (804+807)</b>	<b>1</b>	<b>816</b>		◆

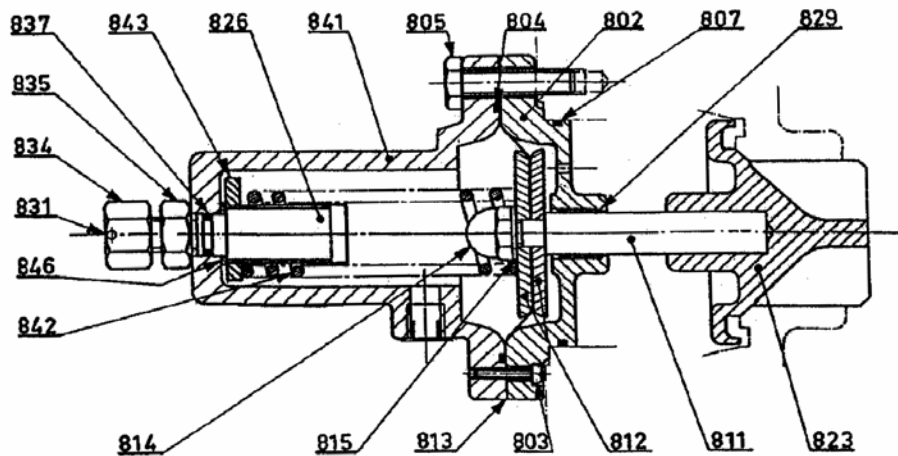

PNEUMATIC BYPASS WITH SPRING

Article code	Description	Quantity	Reference	Wear parts	Notes
<b>304571.00</b>	<b>BYPASS ASSEMBLY (drawing page 1)</b>	<b>1</b>	<b>820</b>		◆
204839	Valve	1	823		▲
	Bypass cup	1	827		See 820
304566.00	Adjustment device assembly	1	898		◆
	Cup O'ring	1	807		See 899
	Spring guide	1	825		See 898
	Adjusting screw	1	826		See 898
	Pin	1	831		See 899
	Adjustment nut HK M14	1	834		See 899
	Locking nut HM14	1	835		See 899
	Adjustment screw O'ring	1	837		See 899
	Capscrew HM 10 X 25	3	856		See 98
<b>219106</b>	<b>BYPASS SPRING - 4 bar</b>	<b>1</b>	<b>824</b>		▲
<b>204891</b>	<b>BYPASS SPRING - 8 bar</b>	<b>1</b>	<b>824</b>		▲
<b>301900.04</b>	<b>PNEUMATIC BYPASS WITH SPRING</b>	<b>1</b>	<b>840</b>		◆
	Bypass base	1	802		See 840
	Screw CS M4X20	2	803		See 840
	O'ring	1	804		See 844
	Screw HM 10X45	3	805		See 840
	Base O'ring	1	807		See 844
301898.03	Membrane assembly	1	810		◆
	Pushrod	1	811		See 810
	Membrane disc	2	812		See 810
204848	Membrane ■	1	813	X	▲
	Blind nut M10	1	814		See 810
	Seal	1	815		See 810
211605	Valve	1	823		▲
	Bearing	1	829		See 840
	Bypass cap	1	841		See 840
301901.01	Adjustment device assembly	1	845		◆
	Adjusting screw	1	826		See 845
	Pin	1	831		See 844
	Adjustment nut HK M14	1	834		See 844
	Locking nut HM14	1	835		See 844
	Adjustment screw O'ring	1	837		See 844
201222	Spring	1	842		▲
	Spring guide	1	843		See 845
	Washer	1	846		See 845
303352.00	Pneumatic pressure limiter 3,6 bar (not shown)	1	930		◆
<b>301902.00</b>	<b>PNEUMATIC BYPASS WITH SPRING SEALS &amp; FASTENINGS (804+807+831+834+835+837)</b>	<b>1</b>	<b>844</b>		◆
<b>301895.00</b>	<b>SET OF BYPASS SCREWS &amp; SEALS (807+831+834+835+837)</b>	<b>1</b>	<b>899</b>		◆

## Hydraulic driving

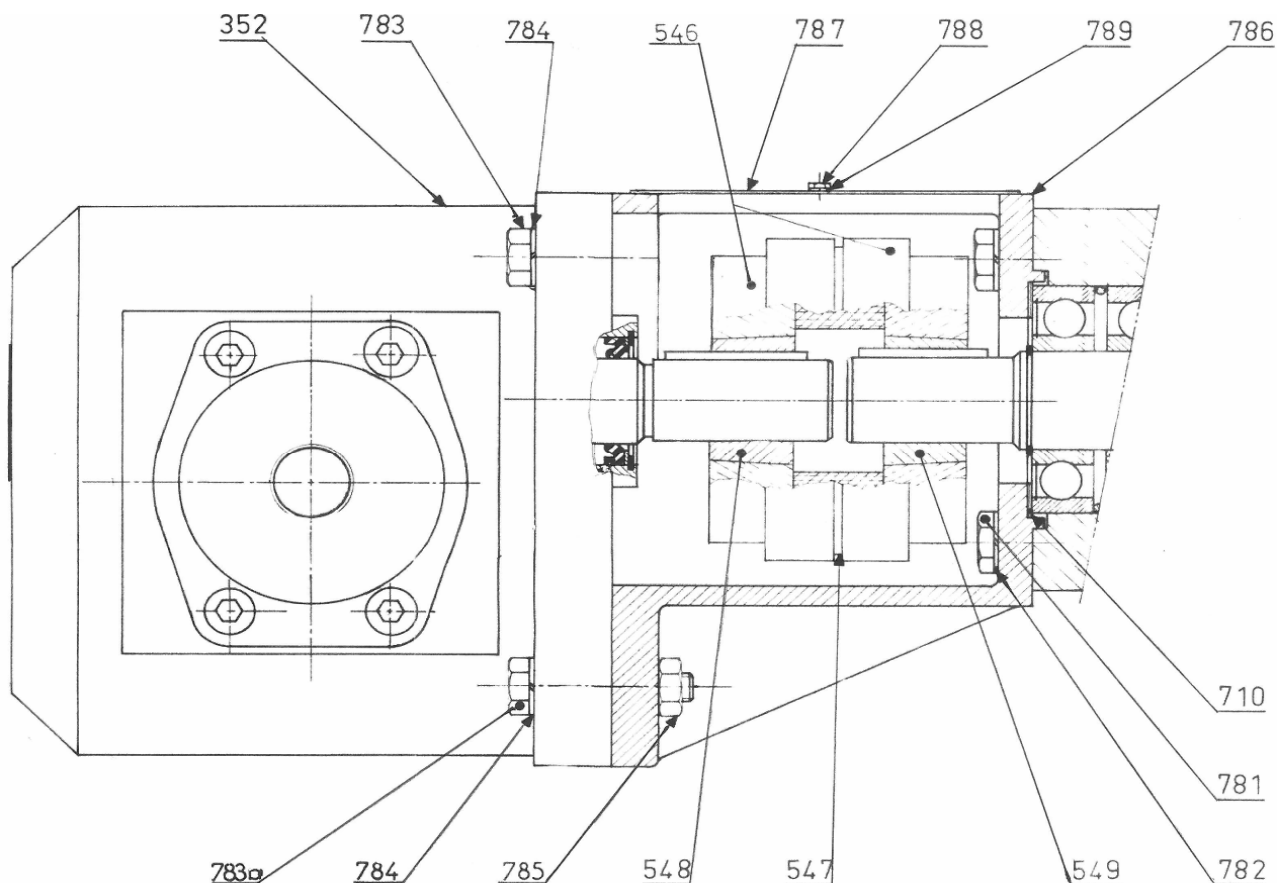

Article code	Description	Quantity	Reference	Wear parts	Notes
<b>305518.02</b>	<b>BEARING ASSEMBLY (for hydraulic trunk)</b>	<b>1</b>	<b>700A</b>		◆
	Ball bearing	2	703		See 704
	Metallic seal	1	733		See 715
	Ring	1	734		See 700A
<b>304155.01</b>	<b>HYDRAULIC TRUNK ASSEMBLY</b>	<b>1</b>	<b>771</b>		◆
204831	Shim	1	710		▲
	Screw HM10 X 25	3	781		See 771
	Washer	3	782		See 771
	Screw M8 X 30	2	783		See 771
	Screw M8 X 40	2	783A		See 771
	Washer	4	784		See 771
	Nut HM8	2	785		See 771
304154.01	Trunk	1	786		▲
	Cover	1	787		See 771
	Screw HM4 X 12	2	788		See 771
	Washer	2	789		See 771
<b>307286.00</b>	<b>HYDRAULIC COUPLING ASSEMBLY</b>	<b>1</b>	<b>546A</b>		◆
	Coupling	2	546		See 546A
	Flexible coupling	1	547		See 546A
	Motor hub	1	548		See 546A
	Pump hub	1	549		See 546A
	<b>HYDRAULIC MOTOR (with straight flanges G3/4)</b>				
<b>505306.00</b>	<b>40 cc</b>	<b>1</b>	<b>352</b>		◆
<b>505388.00</b>	<b>50 cc</b>	<b>1</b>	<b>352</b>		◆
<b>505470.00</b>	<b>60 cc</b>	<b>1</b>	<b>352</b>		◆
<b>505578.00</b>	<b>80 cc</b>	<b>1</b>	<b>352</b>		◆

## Accessories

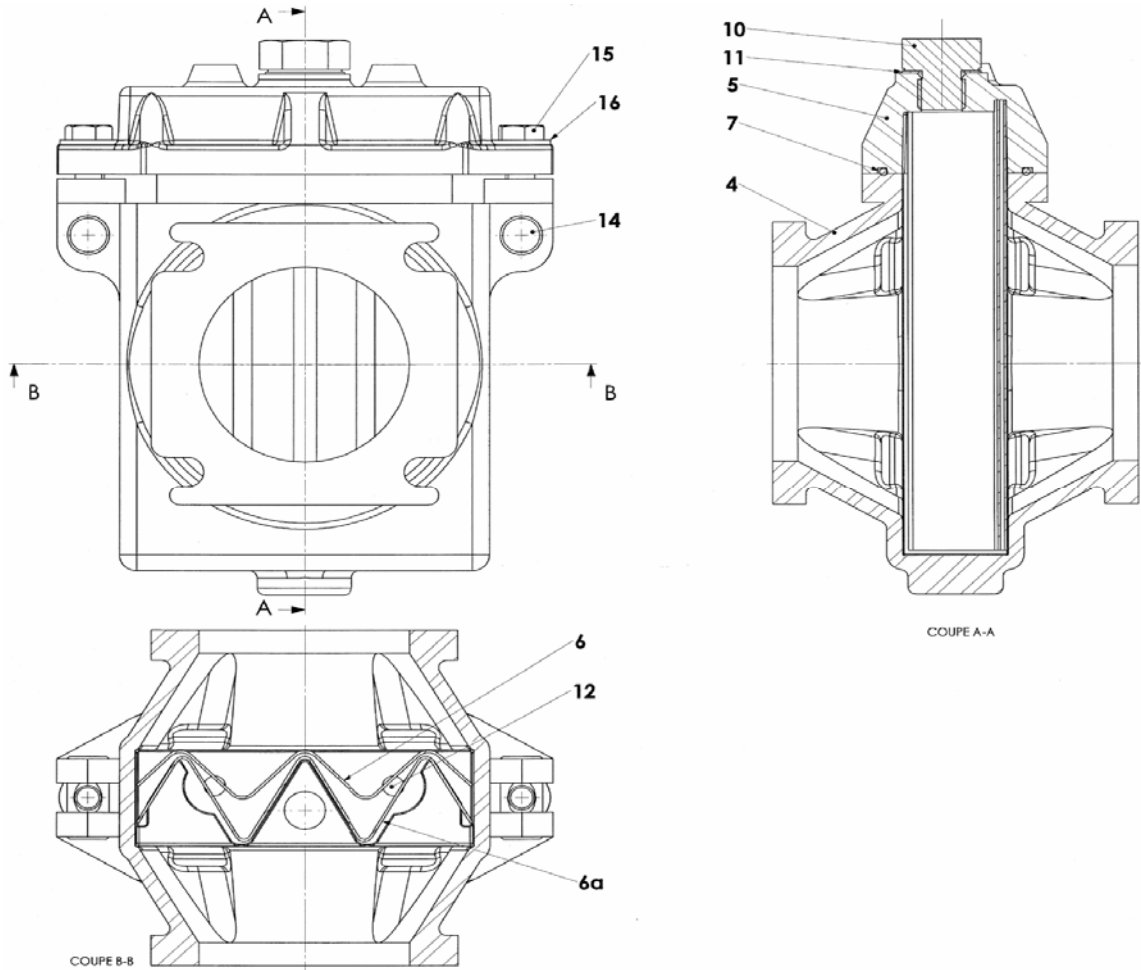

Article code	Description	Quantity	Reference	Wear parts	Notes
302474.00	<b>FLANGES KIT - Steel (not shown)</b>	1	129A		◆
310323.00	<b>FLANGES KIT - Stainless steel (not shown)</b>	1	129A		◆
	Flange bored diameter 91mm	2	129		See 129A
223098	Gasket	2	131		▲
	Screw HM10 X 25 (steel)	8	132		See 129A
	Screw HM10 X 30 (stainless steel)	8	132		See 129A
	<b>STRAINER PF80 CC8</b>				
503660.01	<b>with steel grids</b>	1			◆
503661.01	<b>with stainless steel grids</b>	1			◆
302056.00	Casing assembly	1	2		◆
	Casing	1	4		See 2
302030.00	Rotating bolts assembly	1	8		◆
	Axle	2	14		See 8
	Screw HM10 X 50	2	15		See 8
	Washer	2	16		See 8
302529.01	Cover assembly (Steel grids) (1)	1	3		◆
302530.01	Cover assembly (Stainless steel grids) (1)	1	3		◆
	Cover	1	5		See 3
	Grid 4 mm	1	6		See 3
200874	O'ring ■ (1)	1	7		▲
	Rivet	2	12		See 3
302044.00	Plug assembly	1	13		◆
	Plug	1	10		See 13
	Seal	1	11		See 13
202232	Grid 1 mm (Steel) (1) (2)	1	6A		▲
204723	Grid 1 mm (Stainless steel) (1) (2)	1	6A		▲

Article code	Description	Quantity	Reference	Wear parts	Notes
	<b>STRAINER PF80 CC8</b>				
<b>507251.02</b>	<b>with Nickel treatment and Stainless steel grids</b>	<b>1</b>			◆
314545.00	Casing assembly	1	2		◆
	Casing	1	4		See 2
307246.00	Rotating bolts assembly	1	8		◆
	Axle	2	14		See 8
	Screw HM10 X 50	2	15		See 8
	Washer	2	16		See 8
314546.01	Cover assembly (1)	1	3		◆
	Cover	1	5		See 3
	Grid 4 mm	1	6		See 3
200874	O'ring ■ (1)	1	7		▲
	Rivet	2	12		See 3
307249.00	Plug assembly	1	13		◆
	Plug	1	10		See 13
	Seal	1	11		See 13
204723	Grid 1 mm (1) (2)	1	6A		▲

(1) The cover design changed in September 2011, the gasket 7 is replaced by an O'ring. The cover assembly is interchangeable.

The gasket 7 is no more supplied. In case of need, the complete cover assembly has to be replaced.

(2) The cover design change modified the grid length which is no more interchangeable. In this case, the complete cover assembly has to

(■) Recommended parts to have on stock

(◆) Sets of parts sold only in a kit or (▲) parts available to order.

Keep this parts lists with Installation, Operation and Maintenance Instructions.

To order the required spare parts, indicate the appropriate CUM numbers.



Z.I. la Plaine des Isles - 2 rue des Caillottes F-89000 AUXERRE - France

Tél : +33 (0)3 86 49 86 30 • Fax : +33 (0)3 86 49 87 17

contact@mouvex.com • www.mouvex.com